

ECEN474: (Analog) VLSI Circuit Design

Fall 2011

Lecture 22: Output Stages



Sebastian Hoyos
Analog & Mixed-Signal Center
Texas A&M University

Agenda

- Output Stages
 - Source Follower (Class A)
 - Push-Pull (Class B)
 - Push-Pull w/ Small Quiescent Current (Class AB)

OpAmps and OTAs

OpAmp

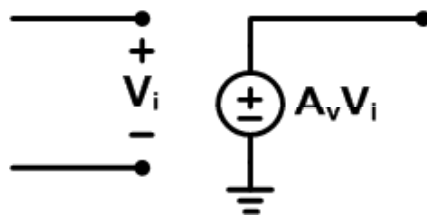
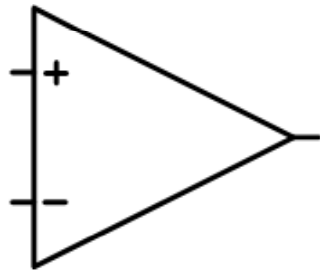

- High voltage gain
- High input impedance
- Voltage source output (low impedance)

OTA

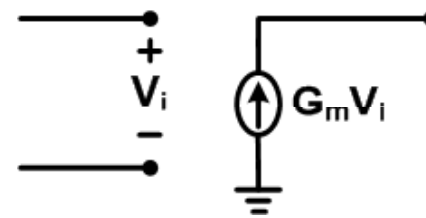
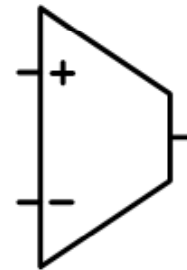

- High "voltage" gain
- High input impedance
- Current source output (high impedance)

Three-Stage OpAmp

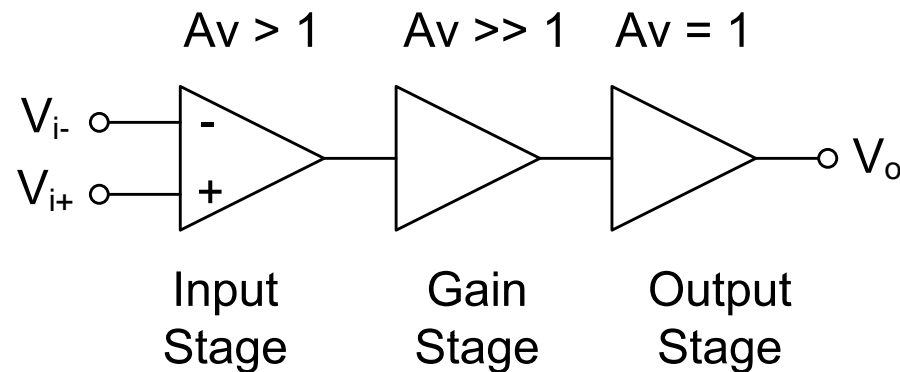

- Differential input stage
 - Amplifies differential input
 - Sets specs such as G_m , CMRR, and slew rate
- Second gain stage
 - Provides additional gain
 - Often used to provide Miller compensation
- Output stage
 - “Power Amplifier”
 - Large current gain and near unity voltage gain
 - Small output impedance

Buffered OTA = Operational Voltage Amplifier (OPAMP)

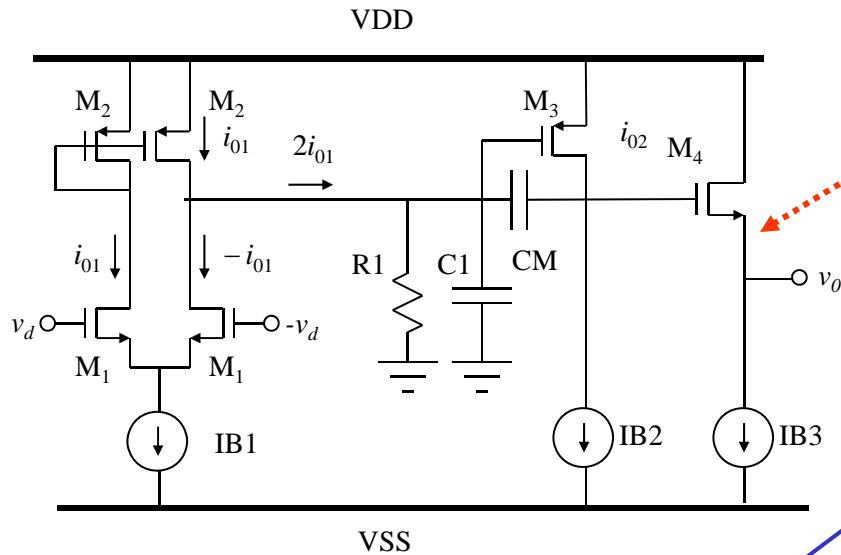

SIMPLE MACROMODEL:

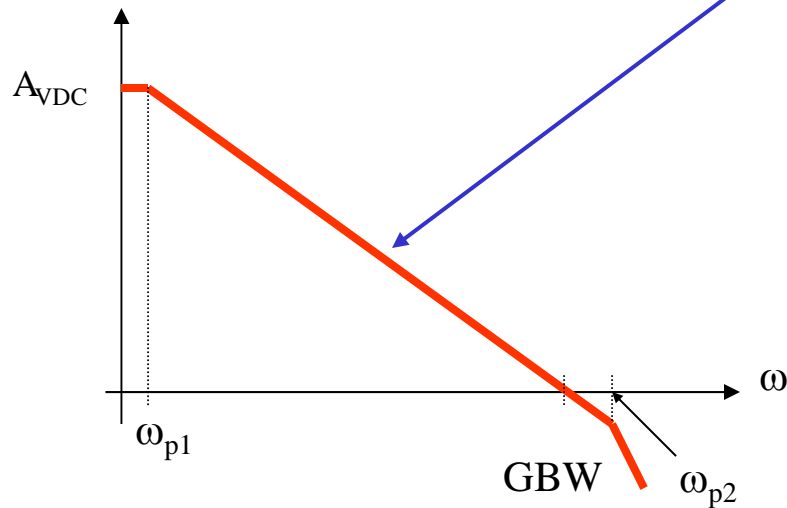
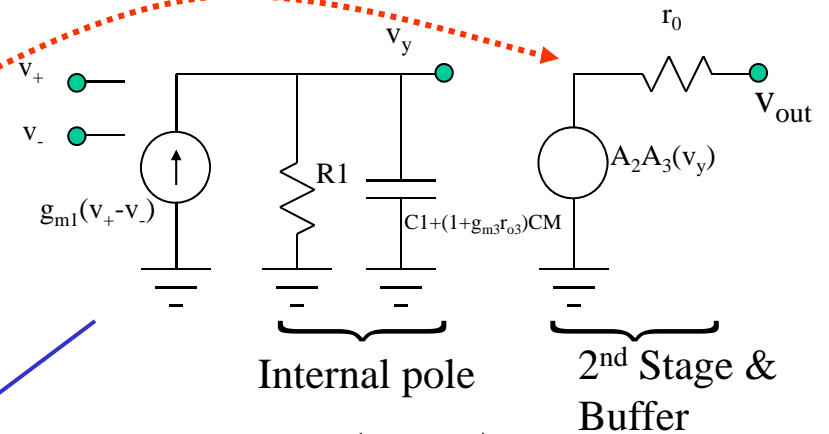

$$A_{VDC} = (g_{m1} R_1) A_2 A_3$$

$$A_2 \approx g_{m3} r_{o3}$$

$$A_3 \approx 1 - 0.5$$

$$GBW \cong \frac{g_{m1}}{C_M}$$

$$R_{out} = r_o \cong 1 / g_{m4}$$

→ Notice that load capacitors must satisfy the following condition, otherwise phase margin is not good enough

$$GBW < \frac{1}{r_o C_L}$$

Source Follower (Class A) Output Stage

[Gray]

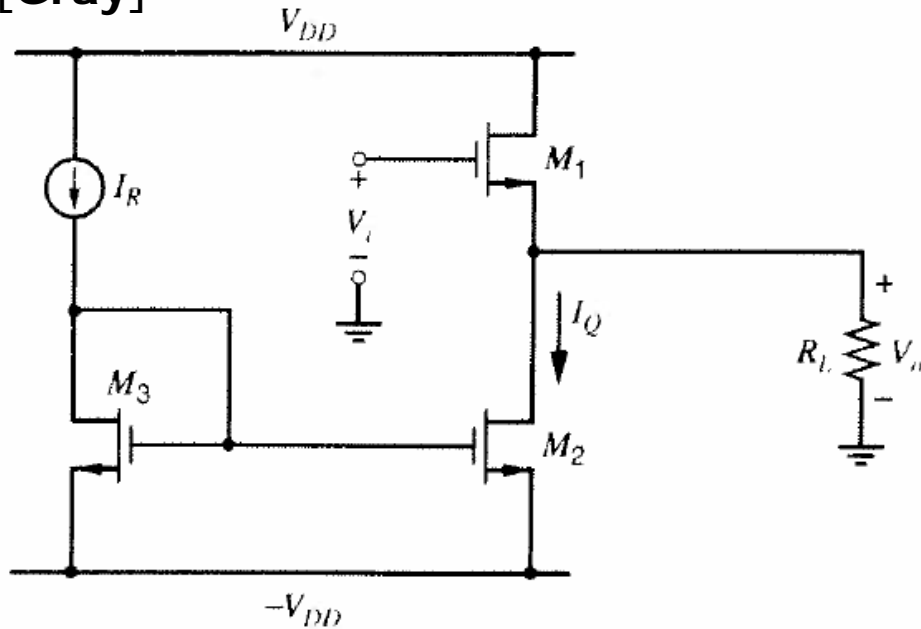

- Voltage gain close to 1
- Low output resistance
- DC level shift of V_{GS1}
- Class A output stage transistors conduct current over an entire input cycle

$$A_{dc} = \frac{g_{m1}}{g_{m1} + g_{o1} + g_{mb1} + g_{o2} + g_L} \approx \frac{g_{m1} R_L}{1 + g_{m1} R_L} \approx 1 \quad (\text{Optimistic})$$

$$R_{out} = \frac{1}{g_{m1} + g_{o1} + g_{mb1} + g_{o2}} \approx \frac{1}{g_{m1}}$$

Source Follower (Class A) Transfer Characteristic

$$V_o = V_i - V_{T1} - \sqrt{\frac{2 \left(I_Q + \frac{V_o}{R_L} \right)}{\mu_n C_{ox} (W/L)_1}}$$

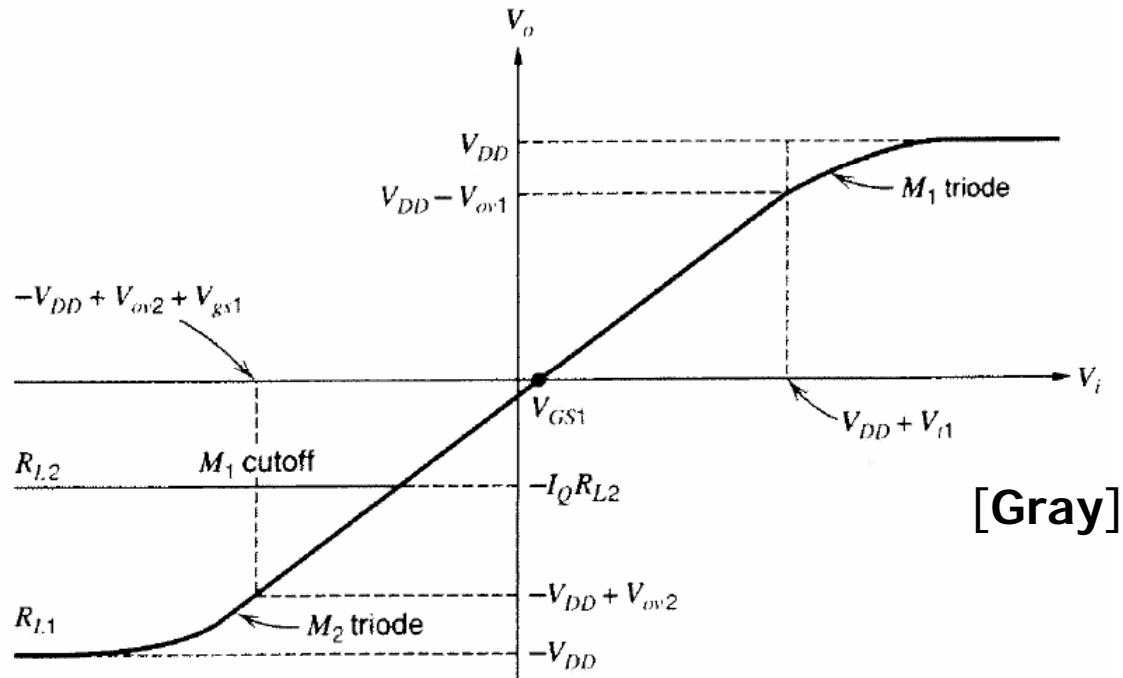

[Gray]

- Maximum V_o
 - If $V_{in} \leq V_{DD}$, then Maximum $V_o = V_{DD} - V_{GS1}$
 - Output transistors remain in saturation up to $V_o = V_{DD} - V_{DSAT1}$ if V_{in} swings up to $V_{DD} + V_{T1}$
- Minimum V_o
 - For small R_L (heavy load), M1 gets cutoff and $V_o \geq -I_Q R_L$
 - For large R_L (light load), M2 will go into triode region at $-V_{DD} + V_{DSAT2}$

Source Follower (Class A)

Power Efficiency

Assuming a sinusoidal output voltage

$$V_o = V_m \sin(\omega t)$$

The power delivered to the load at the signal frequency ω is

$$P_{ac} = \frac{\left(\frac{V_m}{\sqrt{2}}\right)^2}{R_L} = \frac{V_m^2}{2R_L}$$

The average power consumed by the source follower is

$$P_{av} = (-I_Q)(-V_{DD}) + (I_Q)(V_{DD}) = 2I_Q V_{DD}$$

The output stage power efficiency is

$$P_{eff} \equiv \frac{P_{ac}}{P_{av}} = \frac{V_m^2}{4R_L I_Q V_{DD}}$$

Maximum power efficiency is achieved when the output amplitude approaches V_{DD} and I_Q is designed to be $\frac{V_{DD}}{R_L}$

$$\text{Max } P_{eff} = \frac{1}{4} \text{ or } 25\% \text{ (not that good!)}$$

Super Buffer Output Stage

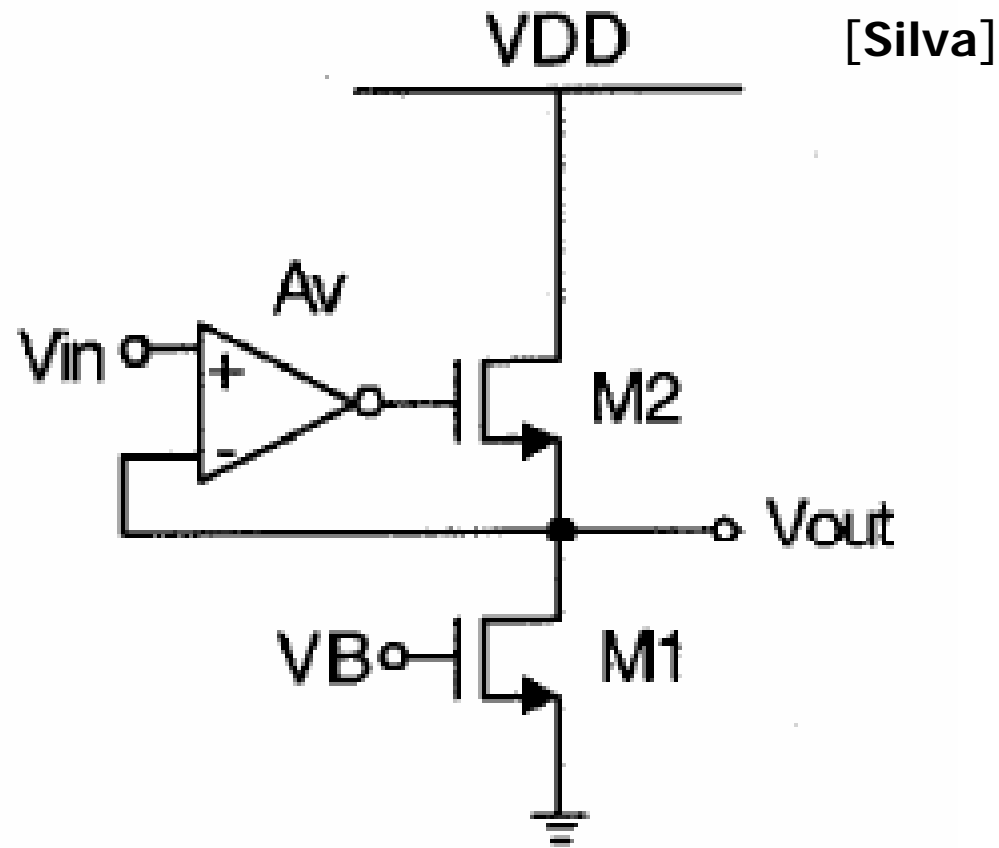

$$R_{out} \approx \frac{1}{g_{m2}(1 + A_v)}$$

Push-Pull Source Follower (Class B) Output Stage

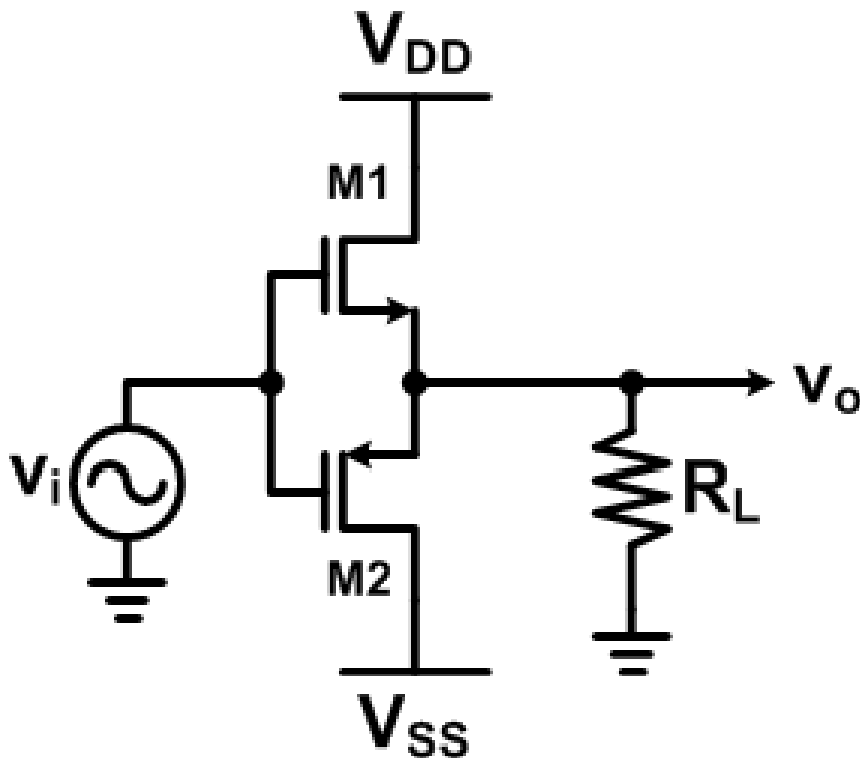

- Class B output stages improve power efficiency by operating at zero quiescent current
- However, if $-|V_{TP}| \leq v_{in} \leq V_{TN}$, then no output signal

Push-Pull Source Follower (Class B) Crossover Distortion

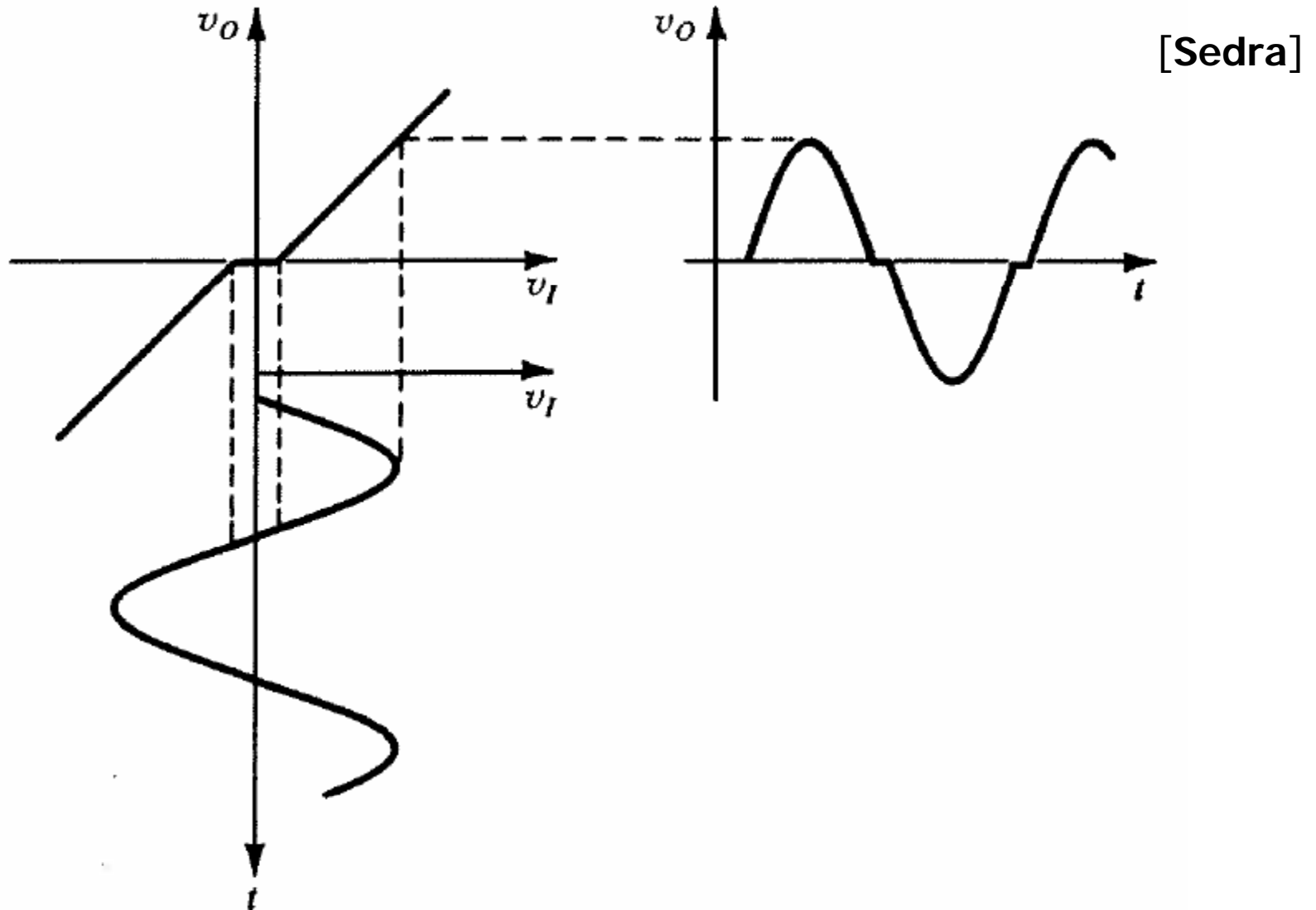

Push-Pull Source Follower (Class B) Power Efficiency

Assuming a sinusoidal output voltage

$$V_o = V_m \sin(\omega t)$$

The power delivered to the load at the signal frequency ω is

$$P_{ac} = \frac{\left(\frac{V_m}{\sqrt{2}}\right)^2}{R_L} = \frac{V_m^2}{2R_L}$$

The current consumed by the push - pull stage from the two supplies

consists of half - sine wave of peak amplitude $\frac{V_m}{R_L}$

The average current will be $\frac{V_m}{\pi R_L}$

$$P_{av} = \left(-\frac{V_m}{\pi R_L}\right)(-V_{DD}) + \left(\frac{V_m}{\pi R_L}\right)(V_{DD}) = \frac{2V_m V_{DD}}{\pi R_L}$$

The output stage power efficiency is

$$P_{eff} \equiv \frac{P_{ac}}{P_{av}} = \frac{\pi V_m}{4V_{DD}}$$

Maximum power efficiency is achieved when the output amplitude approaches V_{DD}

$$\text{Max } P_{eff} = \frac{\pi}{4} \text{ or } 78.5\% \text{ (much better!)}$$

Push-Pull w/ Small Quiescent Current (Class AB) Output Stage

[Gray]

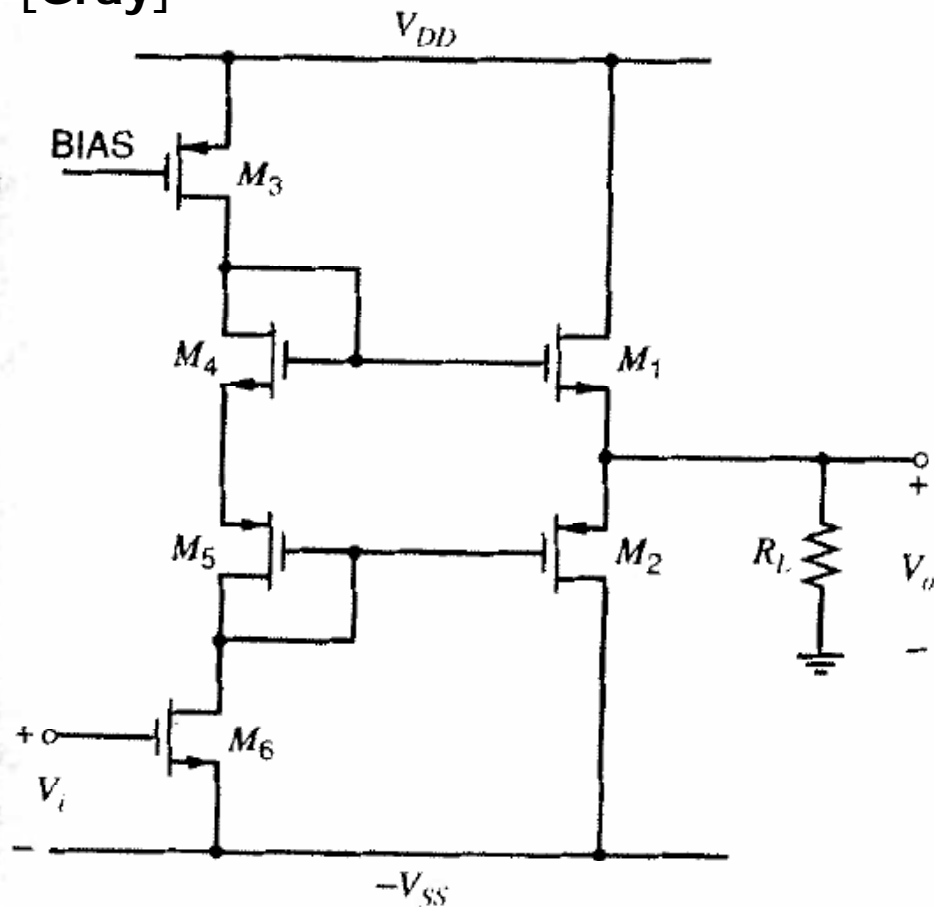

- Power efficiency of the Class-B output stage is great, but the crossover distortion is a major issue
- Solution to the crossover distortion is to bias the transistors into conduction at a low quiescent current
- Level-shift transistors M_4 and M_5 are sized such that V_{GS1} and V_{GS2} are slightly larger than their threshold voltages

Push-Pull w/ Small Quiescent Current (Class AB) Output Swing Range

- A drawback of the CMOS Class AB output stage is the limited output swing range
- Maximum V_o set by M1 source follower
 - $V_o \leq V_{DD} - |V_{DSAT3}| - V_{GS1}$
- Minimum V_o set by M2 source follower
 - $V_o \geq -V_{SS} + V_{DSAT6} + V_{SG2}$

Next Time

- Analog Applications
 - OTA-C Filters
 - Variable-Gain Amplifiers
 - Switch-Cap Filters, Broadband Amplifiers
- Bandgap Reference Circuits
- Distortion