

ELEN 689:Special Topics

Advanced Mixed-Signal Interfaces

Sebastian Hoyos

Texas A&M University
Analog and Mixed Signal Group

Transmitter Digital Predistortion

Digital Predistortion Principle

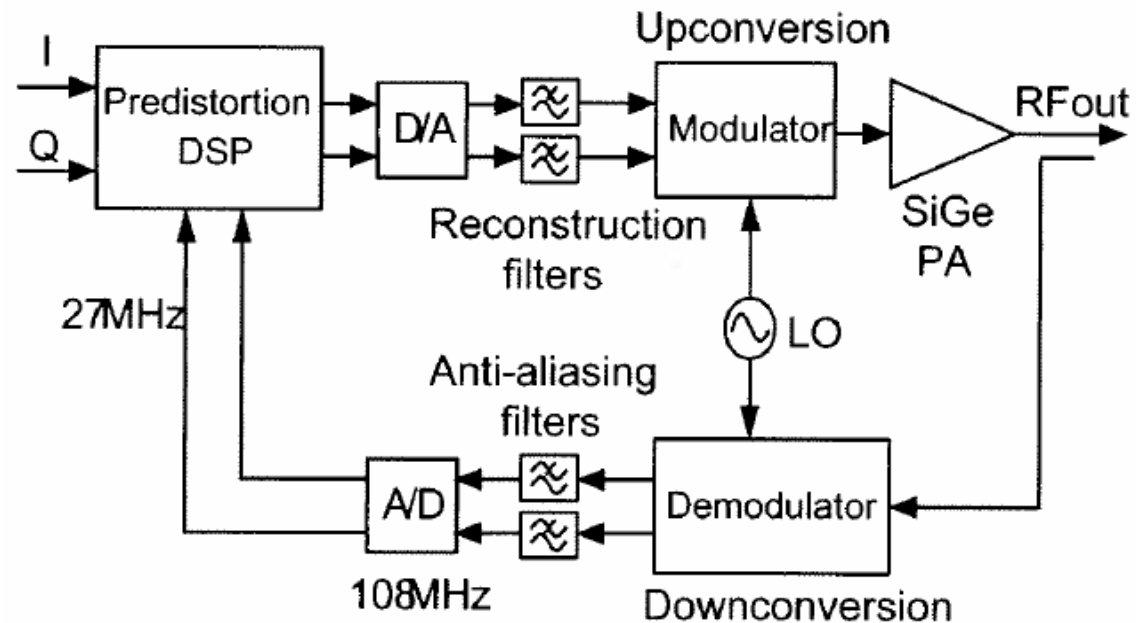

- Shaping of digital data that cancels the distortion of nonlinearities in the analog and RF circuits.
- Issues: Bandwidth expansion, DSP table size and updating, PM-AM errors in modulators

Correction of Power Amplifier Memory and Nonlinearity

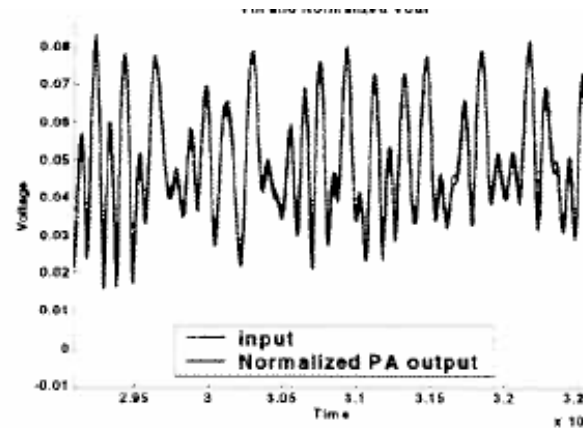

Input and output waveforms vs time (HSDPA signal)

V_{out} vs V_{in}

No correction

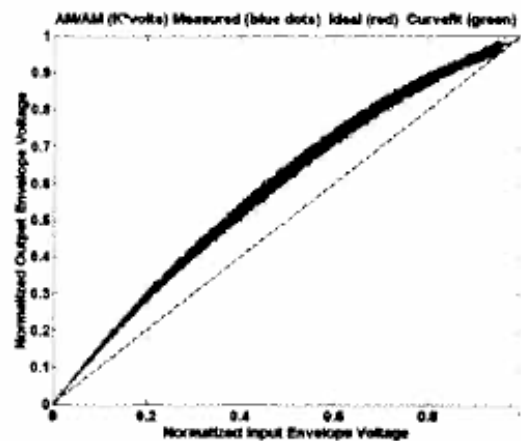

Memoryless correction

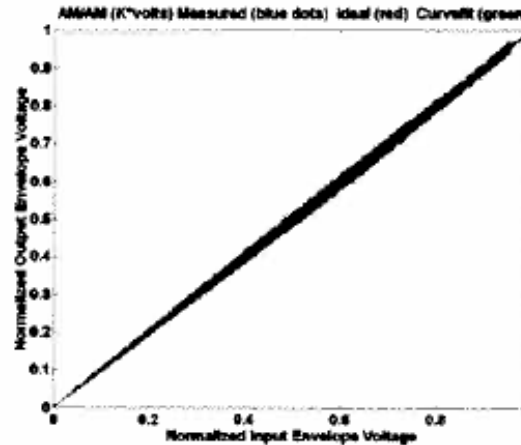

Full correction (with memory effect)

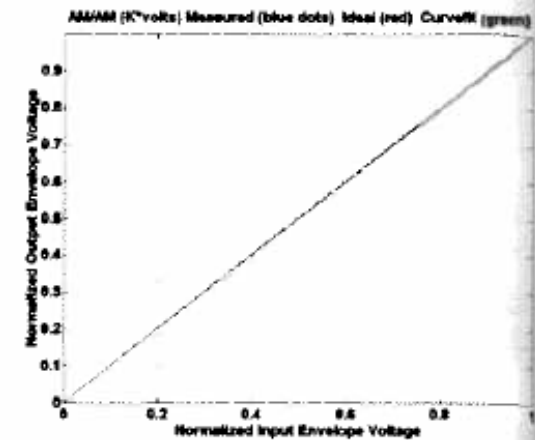

Nonlinear and Memory Effect Mitigation in a WCDMA TX

>50% Efficiency (including V_{dd} amplifier) with
<1% EVM after Memory digital predistortion

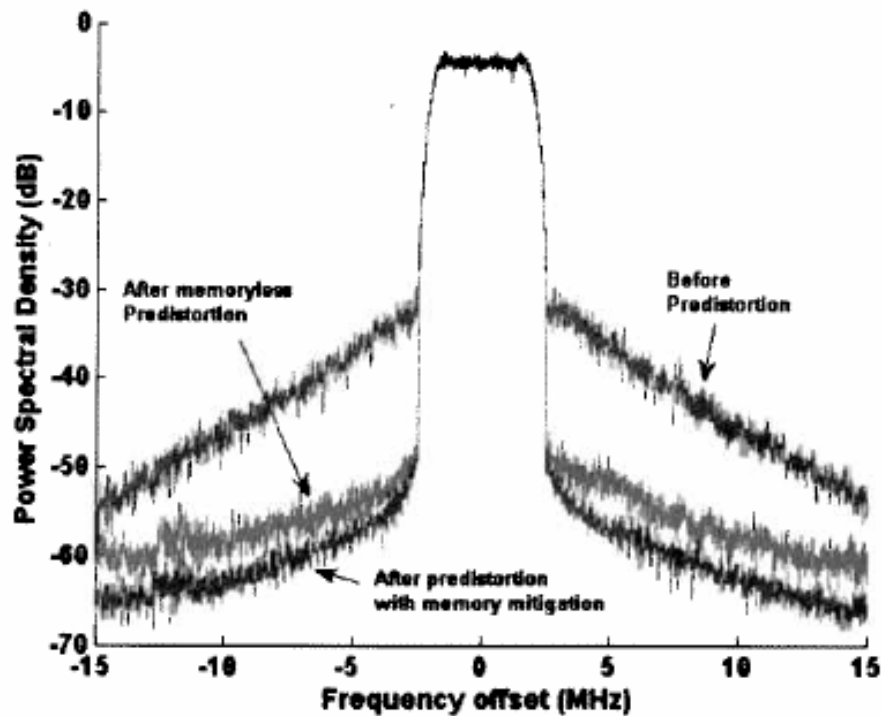

Most spectral regrowth caused by AM/PM distortion rather than AM/AM with Modest memory effects

Nonlinear and Memory Effect Mitigation

7MHz BW WiMAX Spectral Regrowth

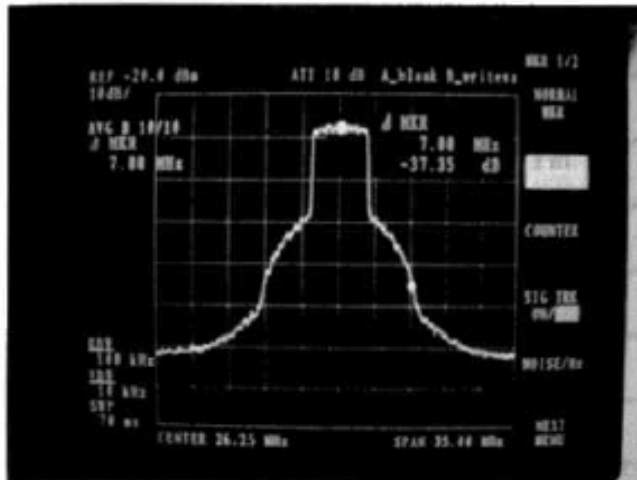

- **Output Before PreDistortion**

- ACPR 7MHz Offset -37dB
- ACPR 14MHz Offset -49dB
- +23dBm PA Output Power
- PreDistorted input spectrum looks similar

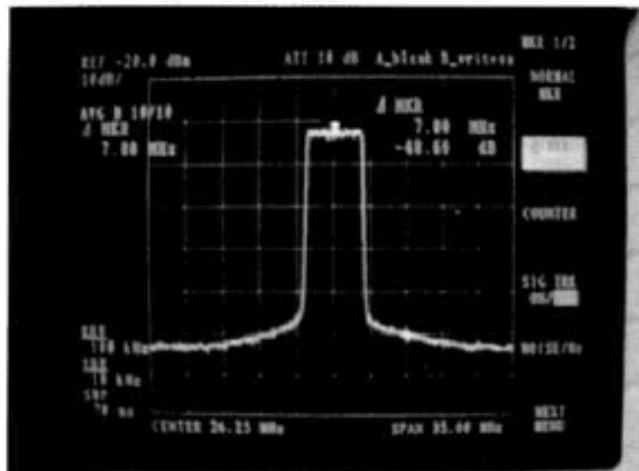

- **After PreDistortion**

- ACPR 7MHz Offset -48dB
- ACPR 14MHz Offset -53dB
- +23dBm Output Power

Impact of Predistortion on the Constellation Error

7MHz BW WiMAX 64-QAM Distortion

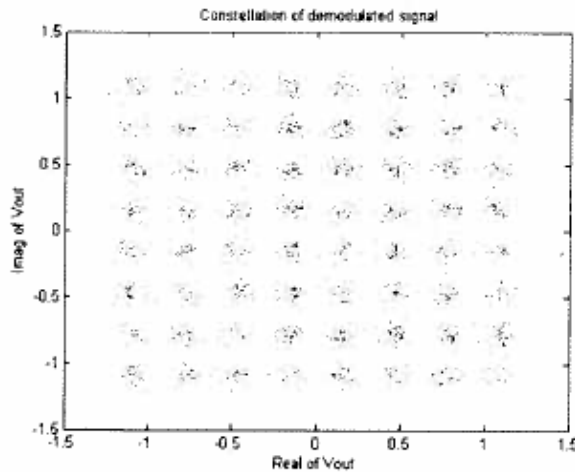

- **Before PreDistortion**
 - **RCE: -22.78 dB**
 - **RCE = Relative Constellation Error**

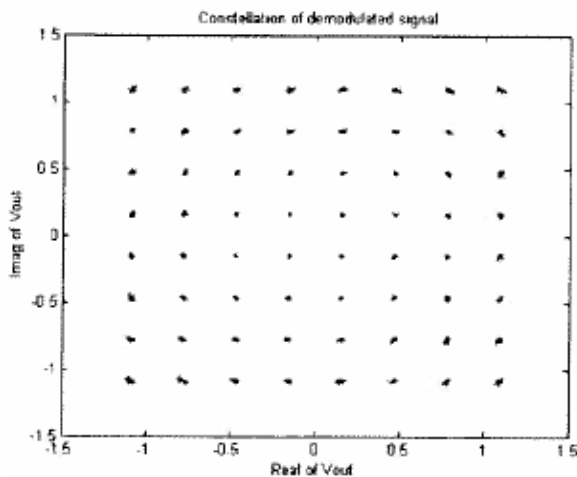

- **After PreDistortion**
 - **RCE: -37.22 dB**
 - **802.16 2004**
 - **RCE < -31dB specification**

Transmitter Digital Predistortion Building Blocks

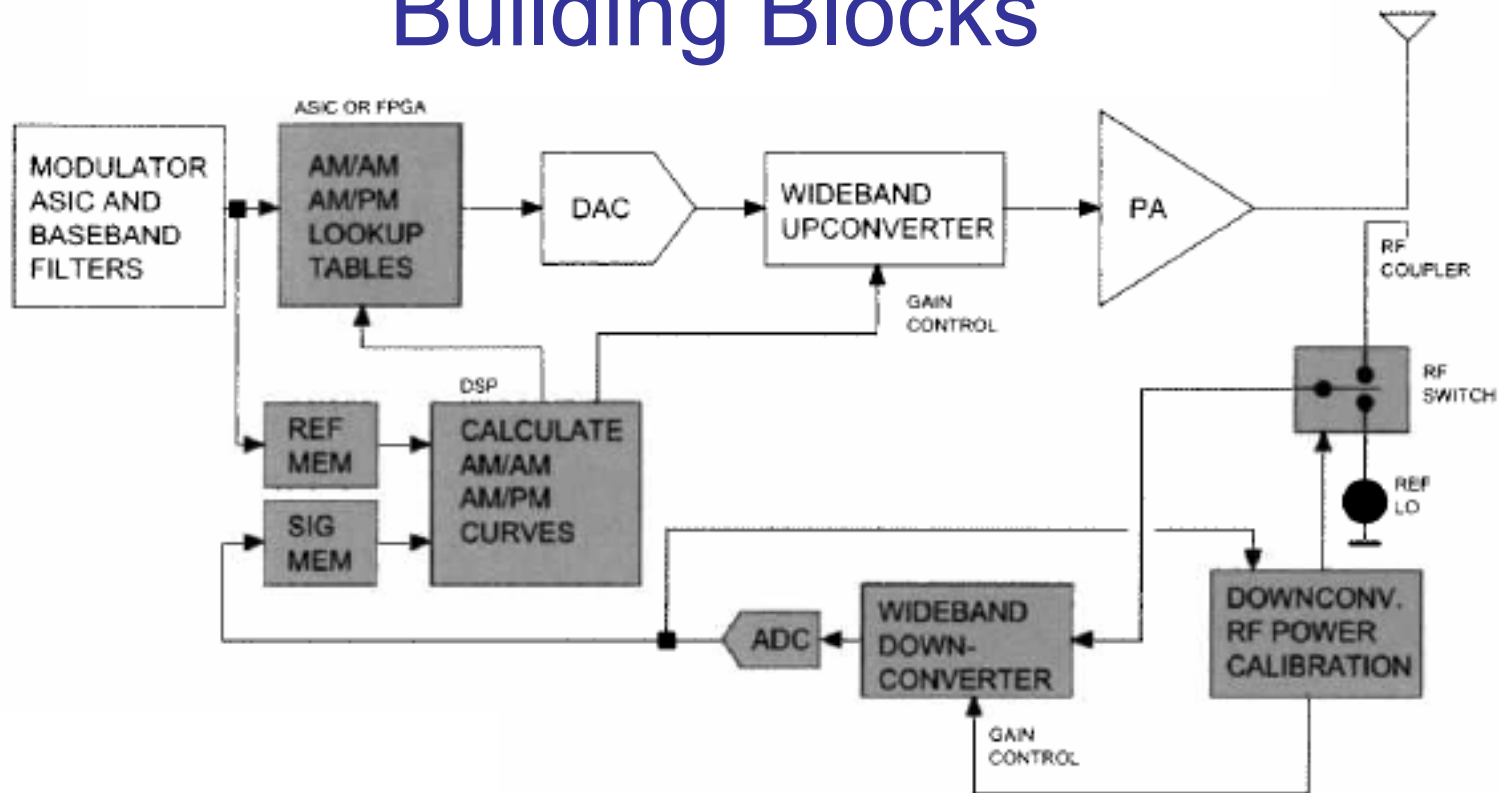

- Reference signal and signal memory stores a sequence of desired and actual signal.
- Data enables DSP to calculate AM/AM and AM/PM correction tables. This is done ongoing, no transmission interruption.
- Between predistortion updates, ref LO is switched in to calibrate gain of the down-converter.

Digital Correction to Errors in Modulators

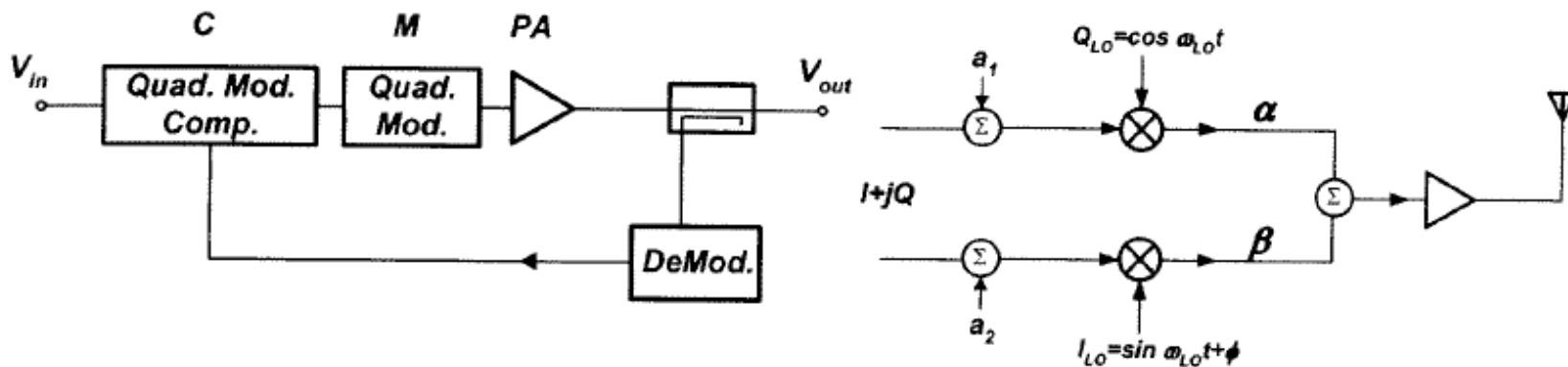

- The modulator has amplitude offset (a_1 , a_2), gain error (α , β) and phase offset Φ .
- Digital predistortion can compensate for the errors.

HW # 2: Find a digital predistortion that cancels the effect of the nonidealities.

Cartesian Feedback Adaptive RF Power Amplifier Linearization

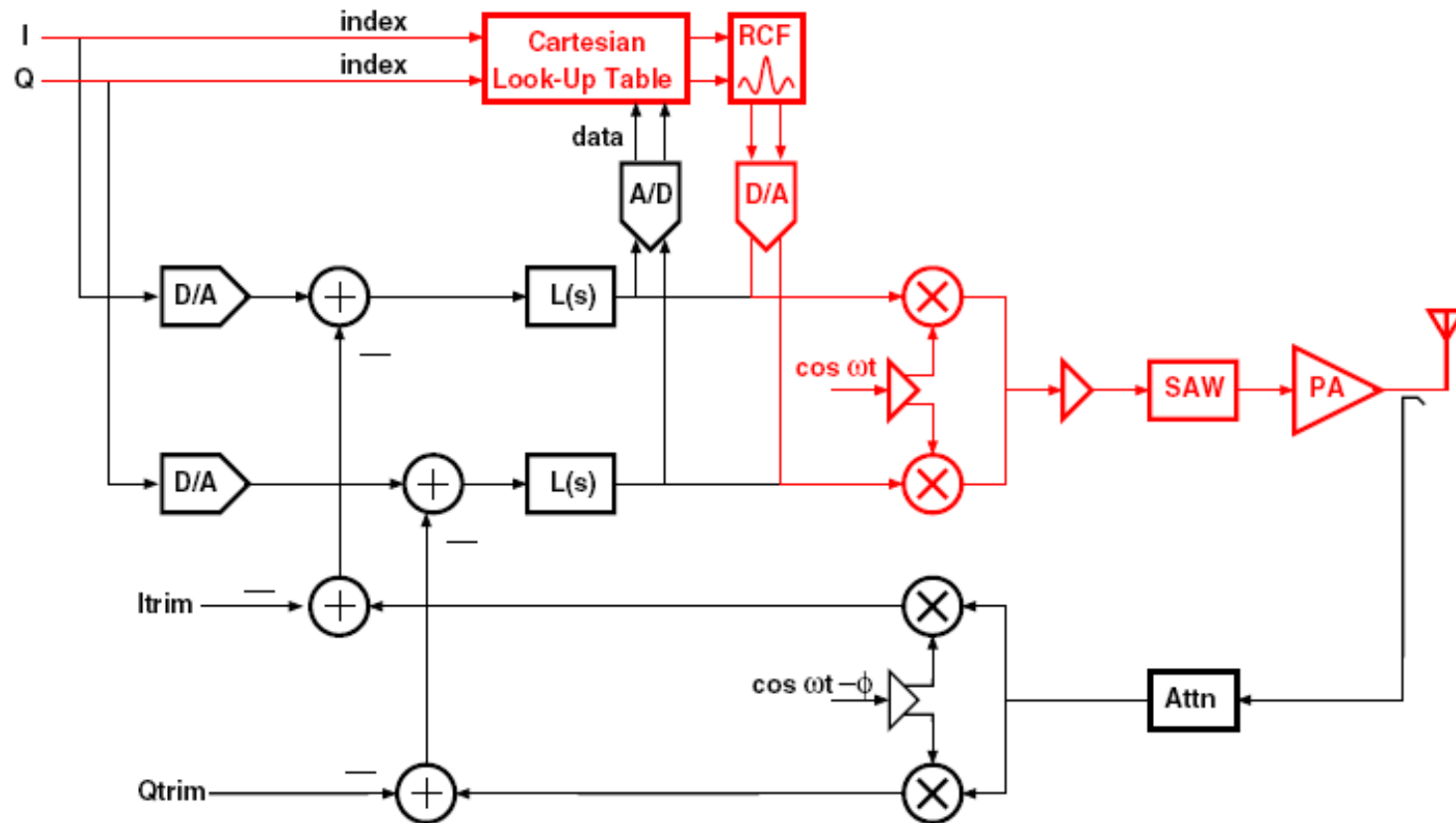

SungWon Chung, e.t. "Open-Loop Digital Predistortion Using Cartesian Feedback for Adaptive RF Power Amplifier Linearization".

Look-up Table in Cartesian Feedback

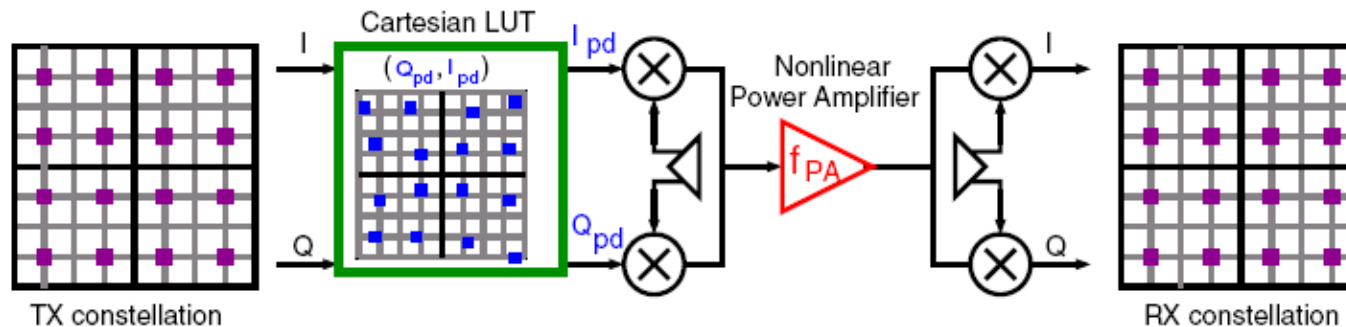

- The cartesian LUT is trained by analog feedback loop.
- The predistorted I and Q data cancels out the PA nonlinearity.
- In contrast with Polar approach, the cartesian approach can reverse nonlinearities that are not rotational symmetric.
- The fundamental equation is $f_{PA}([I_{pd} \ Q_{pd}]) = [I \ Q]$
- There is no parameterized model. No apparent convergence issues.
- Can this approach remove memory issues?

Asymmetry Nonlinearity in the Transmit Path

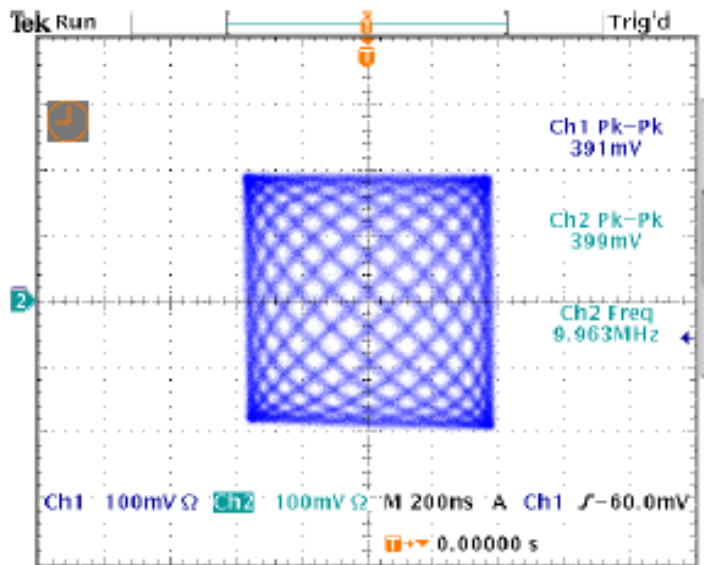

(a)

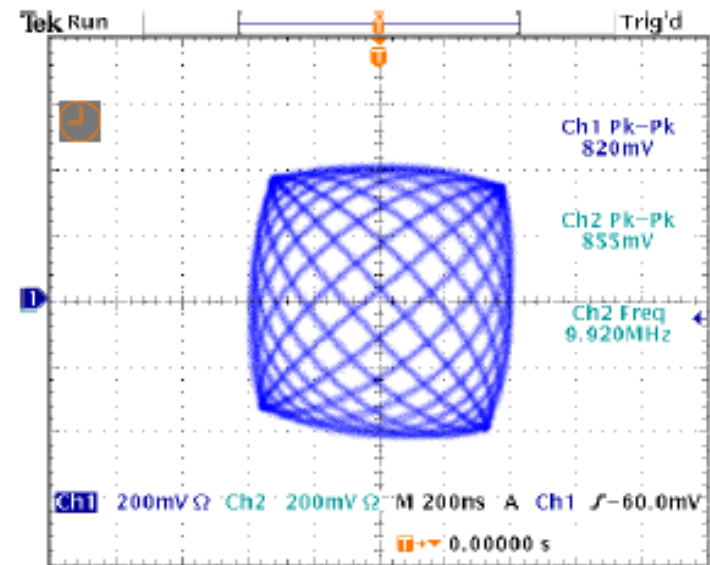

(b)

- Demodulator 900 MHz transmitter output using class-A power amplifier for a rectangular baseband constellation. (a) below PS 1 dB compression point, (b) at PA 1-dB compression point (27 dB).

Transmitted Noise Model

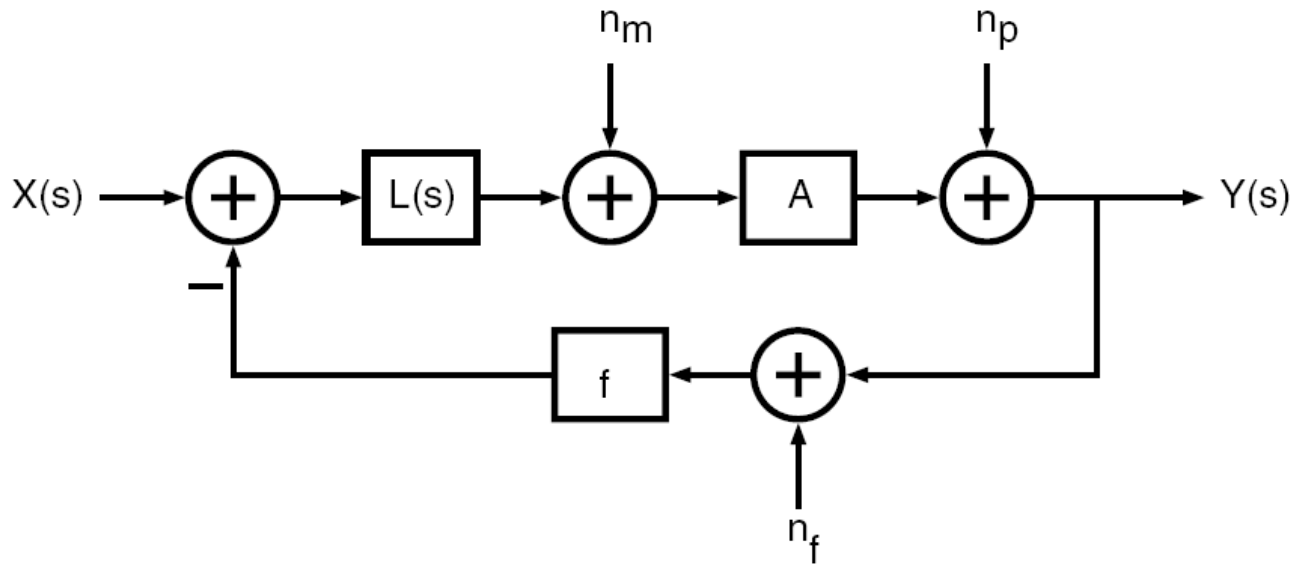

HW # 2(cont.): Find an expression of $Y(s)$ that includes all the noise sources.
Please comment on how to design the building blocks to minimize the noise.

Interpolation Noise in Coarse LUT

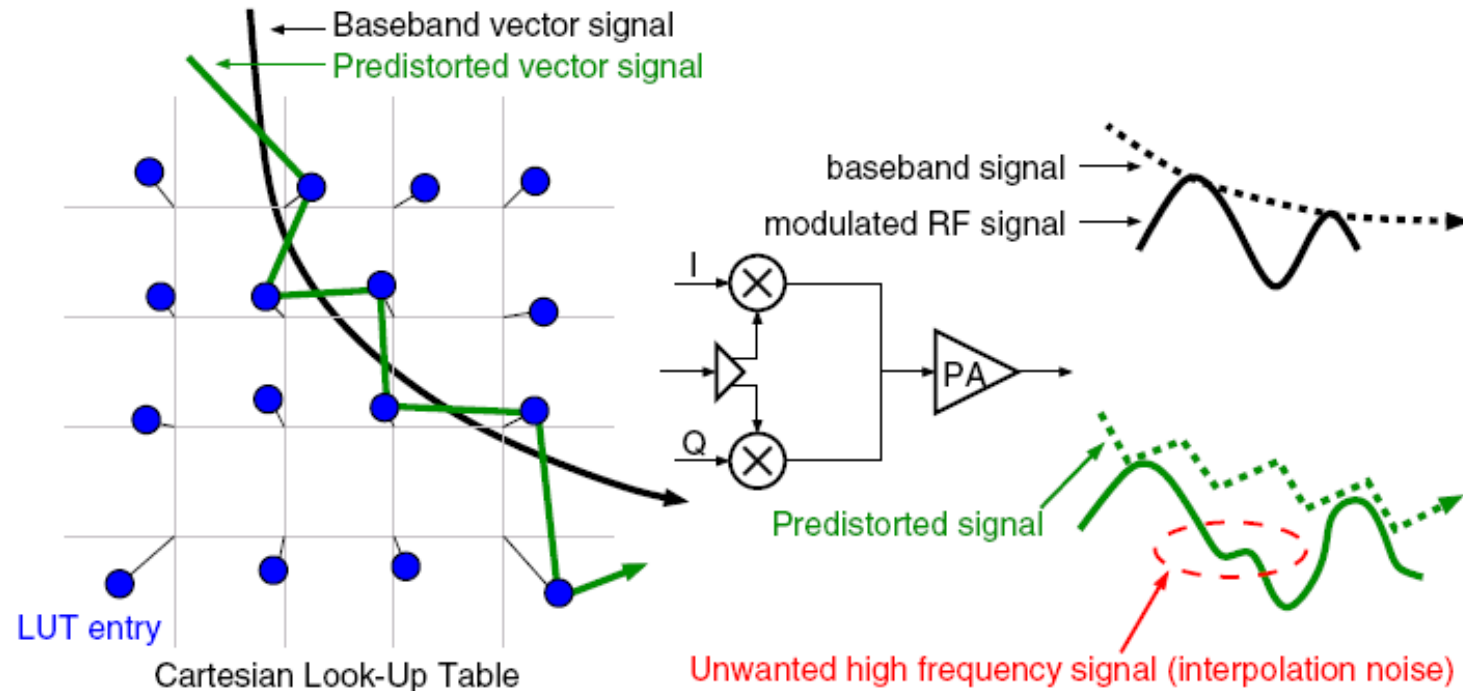

- This is like quantization noise in the coarse LUT.

Noise Sources in Open Loop Predistortion

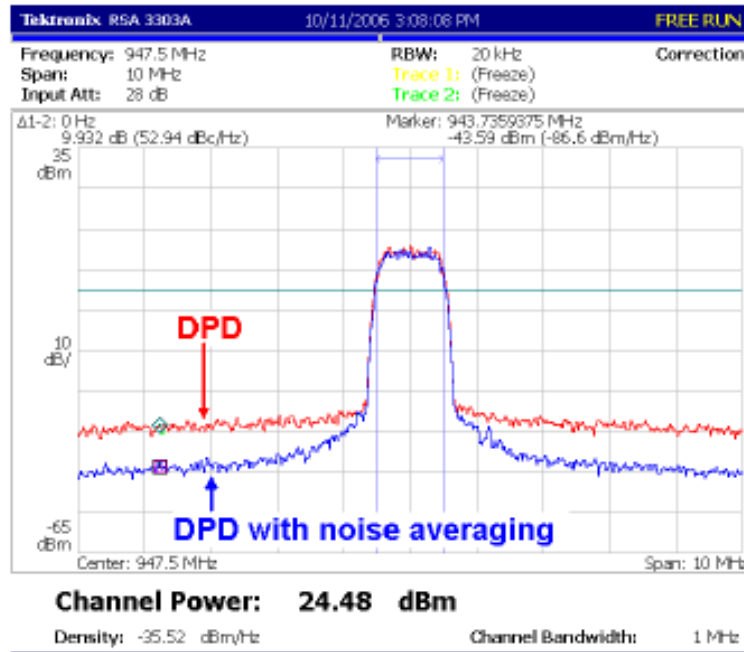

(a)

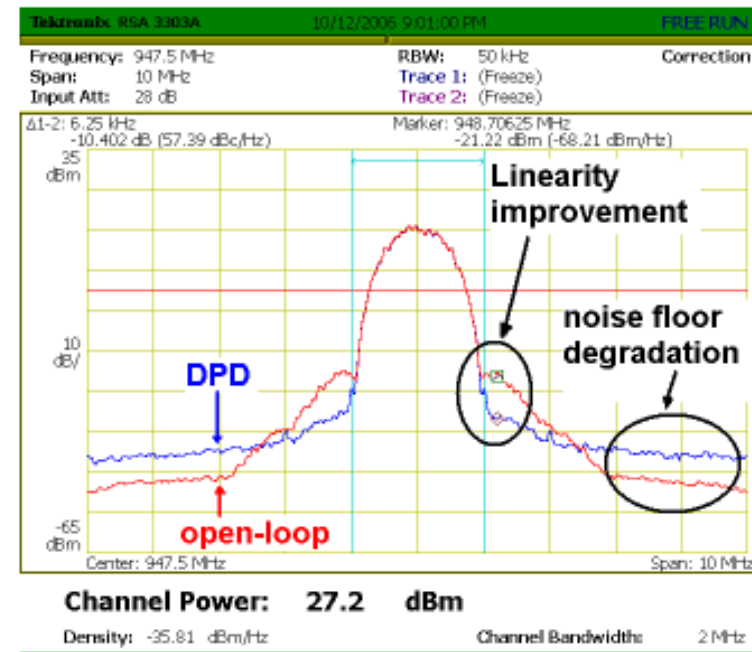

(b)

- Two noise sources in open loop digital predistortion system: (a) downconversion noise, (b) LUT interpolation noise.

Distortion Gain

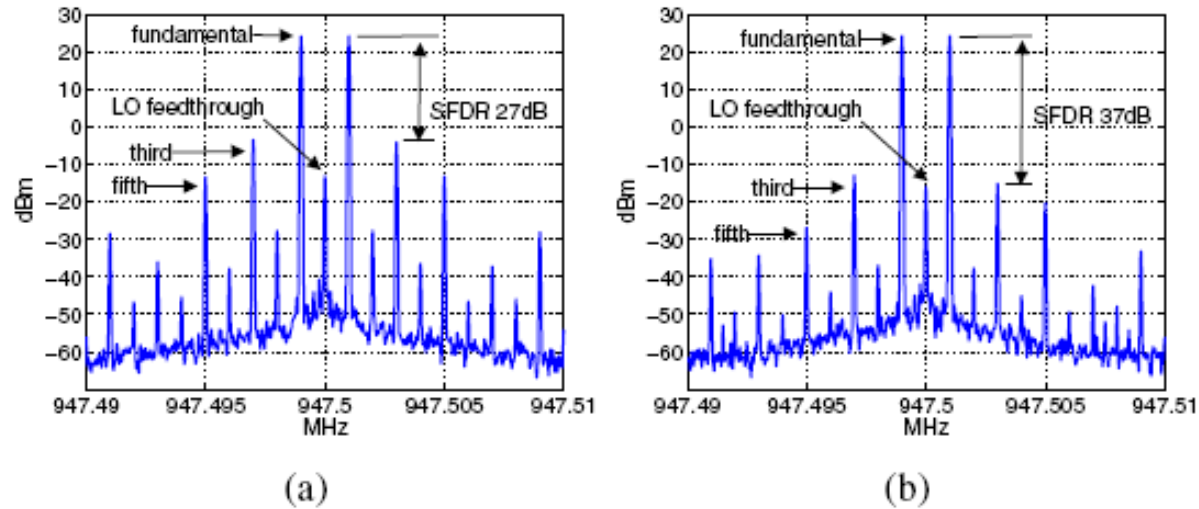

Fig. 7. DSB transmission spectrum of a 1-kHz sinusoid: (a) open-loop transmission without predistortion, (b) open-loop digital predistortion.

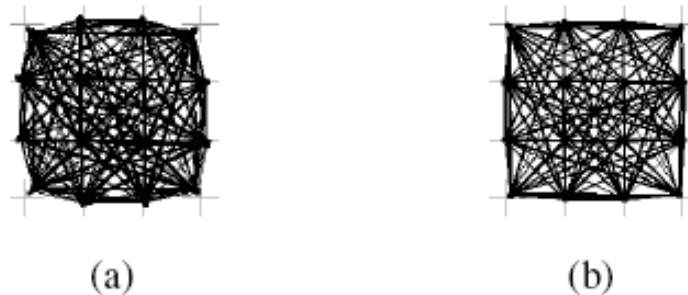

Fig. 8. Measured EVM of open-loop 16-QAM at 28-dBm PA output: (a) 5.98% (without predistortion), (b) 2.22% (with predistortion).

Signal Bandwidth effect and Power

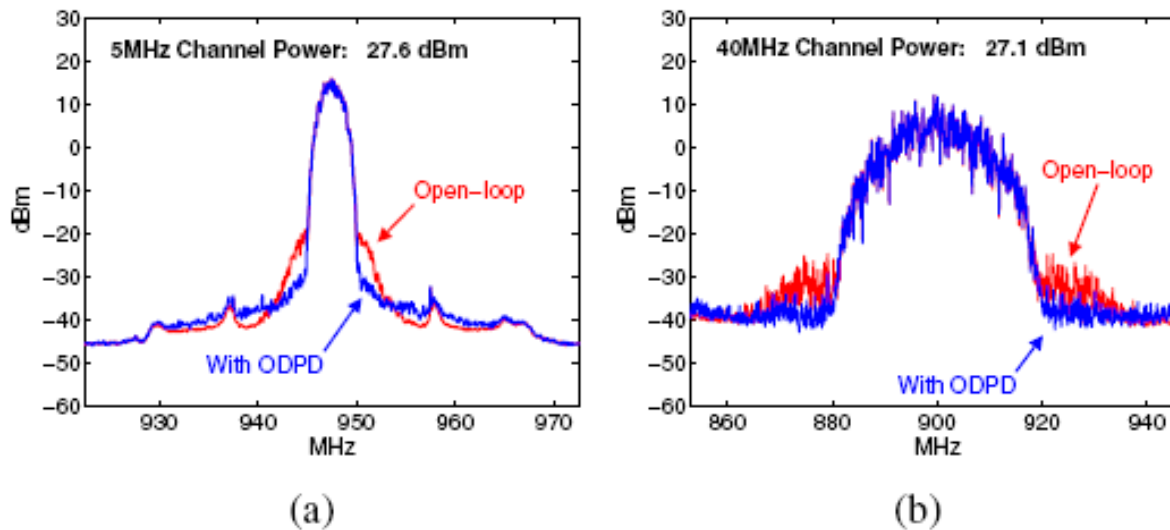

Fig. 9. Open-loop digital predistortion on 16-QAM signals: (a) 5-MHz bandwidth with SAW filter (b) 40-MHz bandwidth without SAW filter.

TABLE I

POWER CONSUMPTION AND MAXIMUM LINEARIZABLE BANDWIDTH

	Overall Power	Saved Power	Linearizable BW
Open-loop	9980 mW	-	-
CFB	6990 mW	2990 mW	10 kHz
ODPD	7635 mW	2345 mW	40 MHz

A Transmitter with an All-digital PLL and Polar Modulation

- Designed for GSM/EDGE
- Uses Polar modulation
- $\Sigma\Delta$ modulator for freq. Information in a digitally controlled VCO.
- PA is also digitally controlled.

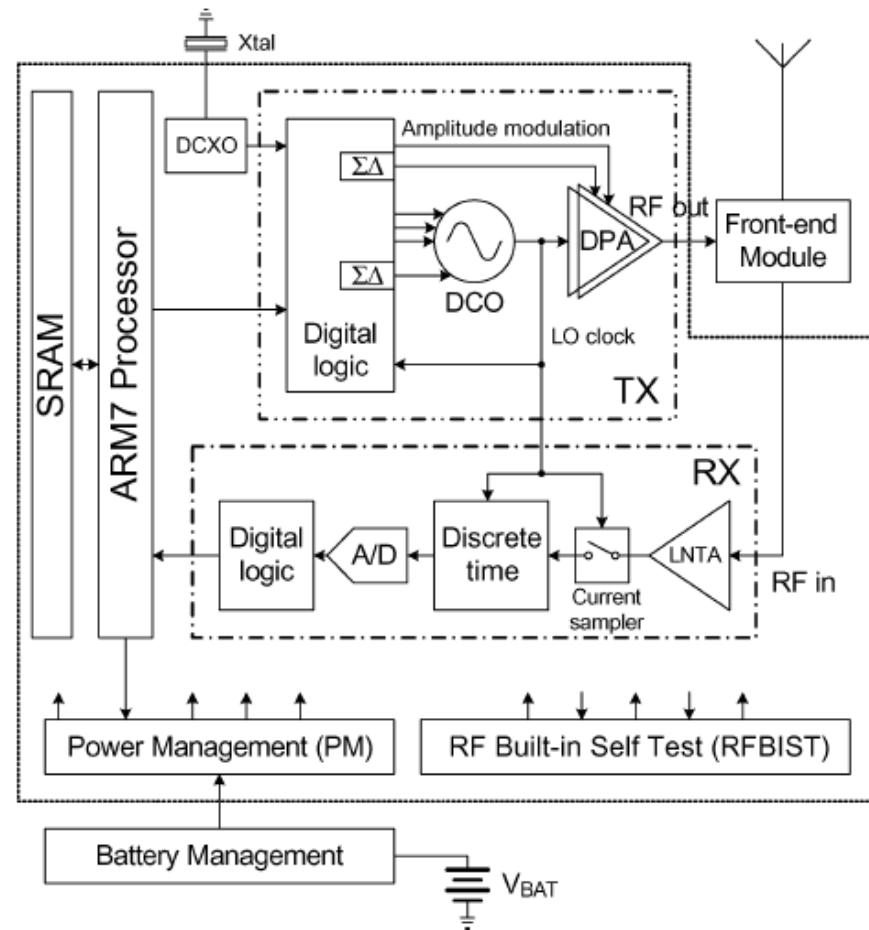

Robert Bogdan Staszewski, et. al, "All-Digital PLL and Transmitter for Mobile Phones" JSSC05

Spring 2009

S. Hoyos - Advanced Mixed-Signal Interfaces

18

Polar Modulation

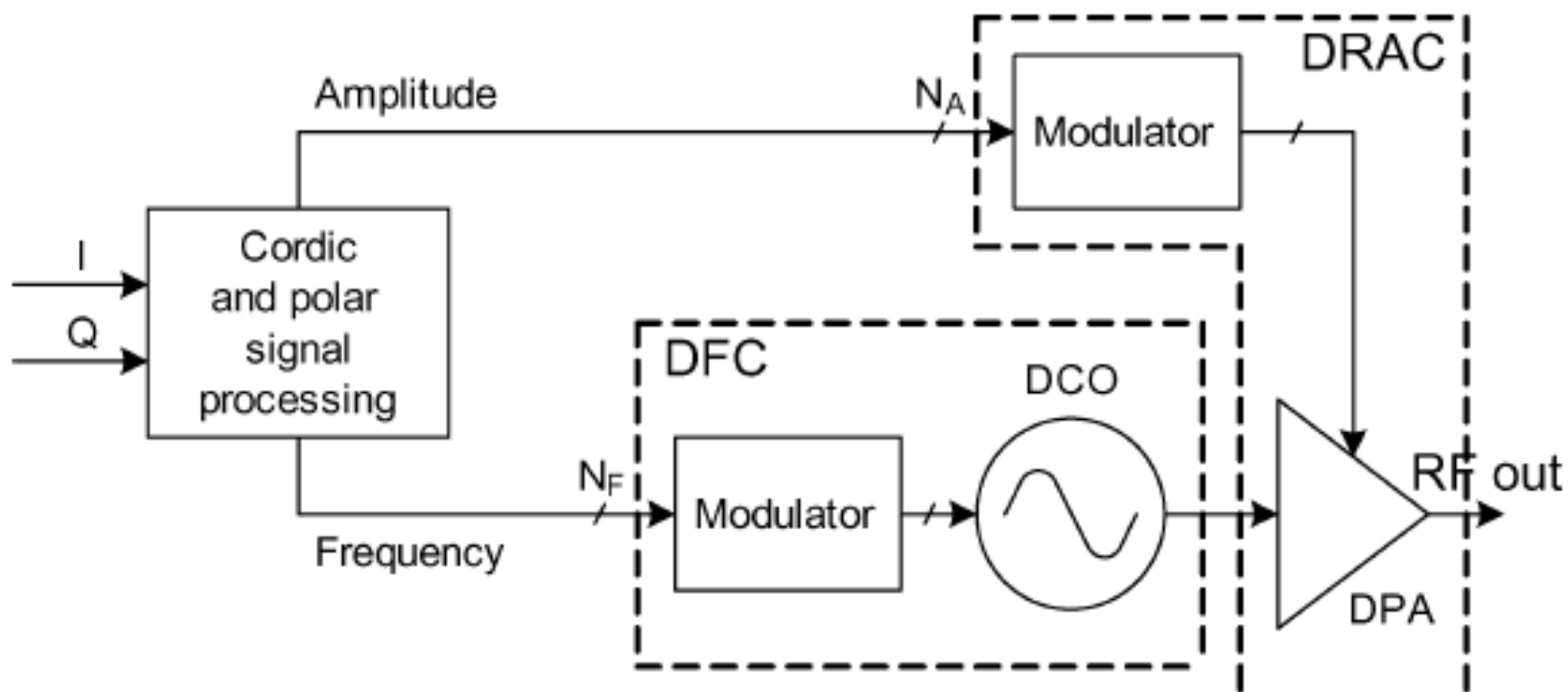

- Digital to Frequency Conversion (DFC) $y_{PM}(t) = \text{sgn}(\cos(\omega_0 t + \theta[k]))$
- Digital to RF Amplitude Conversion (DRAC) $y_{RF}(t) = a[k] \cdot \cos(\omega_0 t + \theta[k])$

DAC Architecture

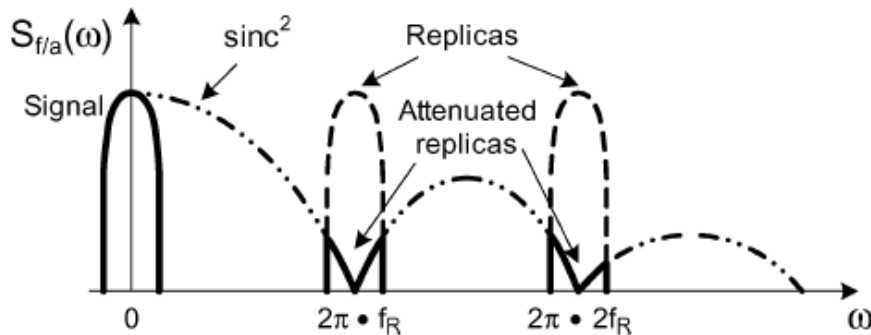
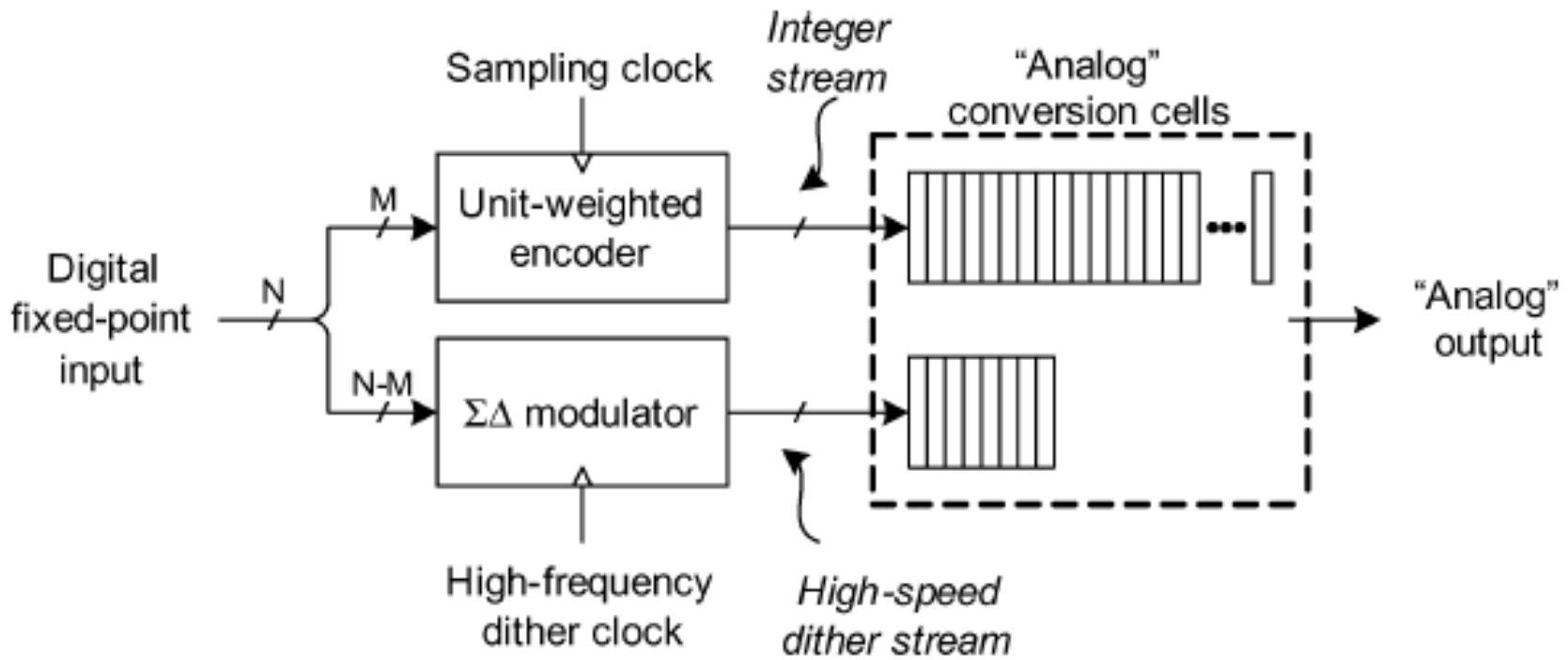

Digitally Controlled Oscillator

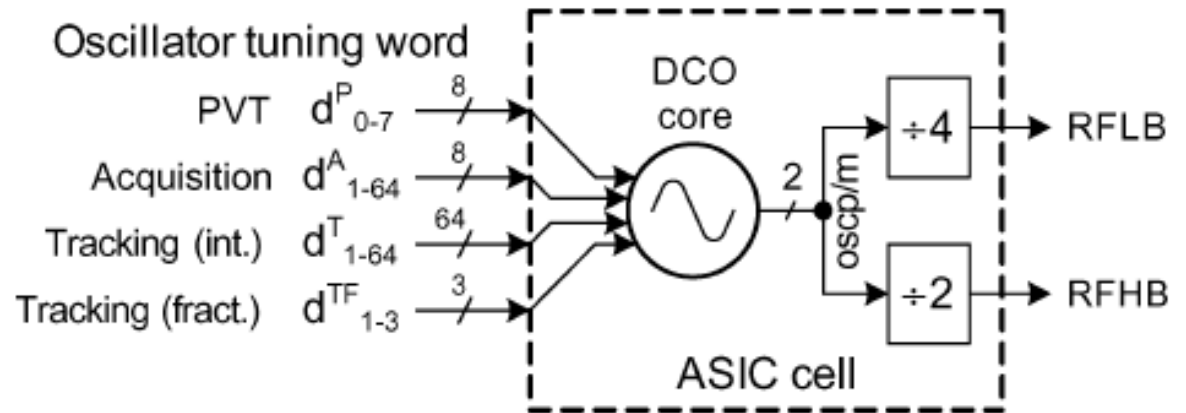
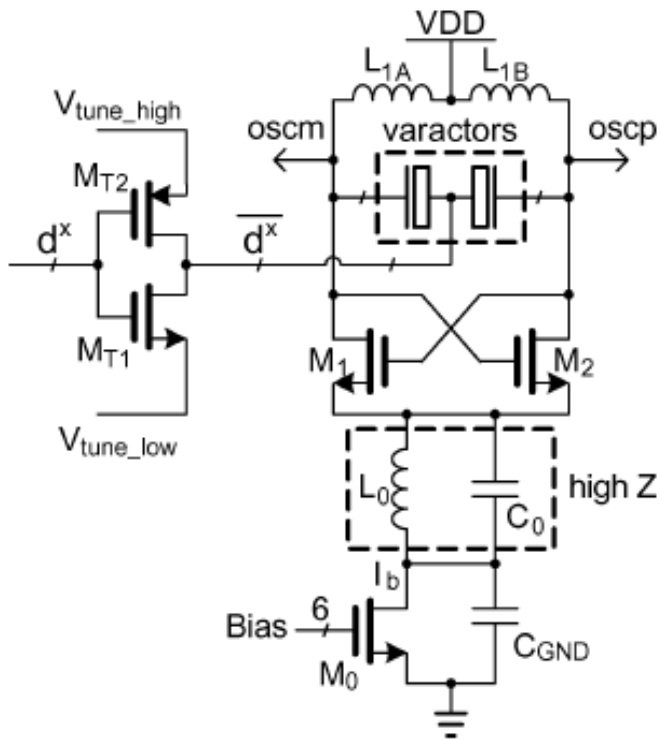

Digitally Controlled PA

- 64 parallel connected NMOS for 6 bits of resolution.
- C1 is on-chip cap while C2 and L1 filters the residual second harmonic. The circuit is single ended.
- Power supply is 1.4 V.

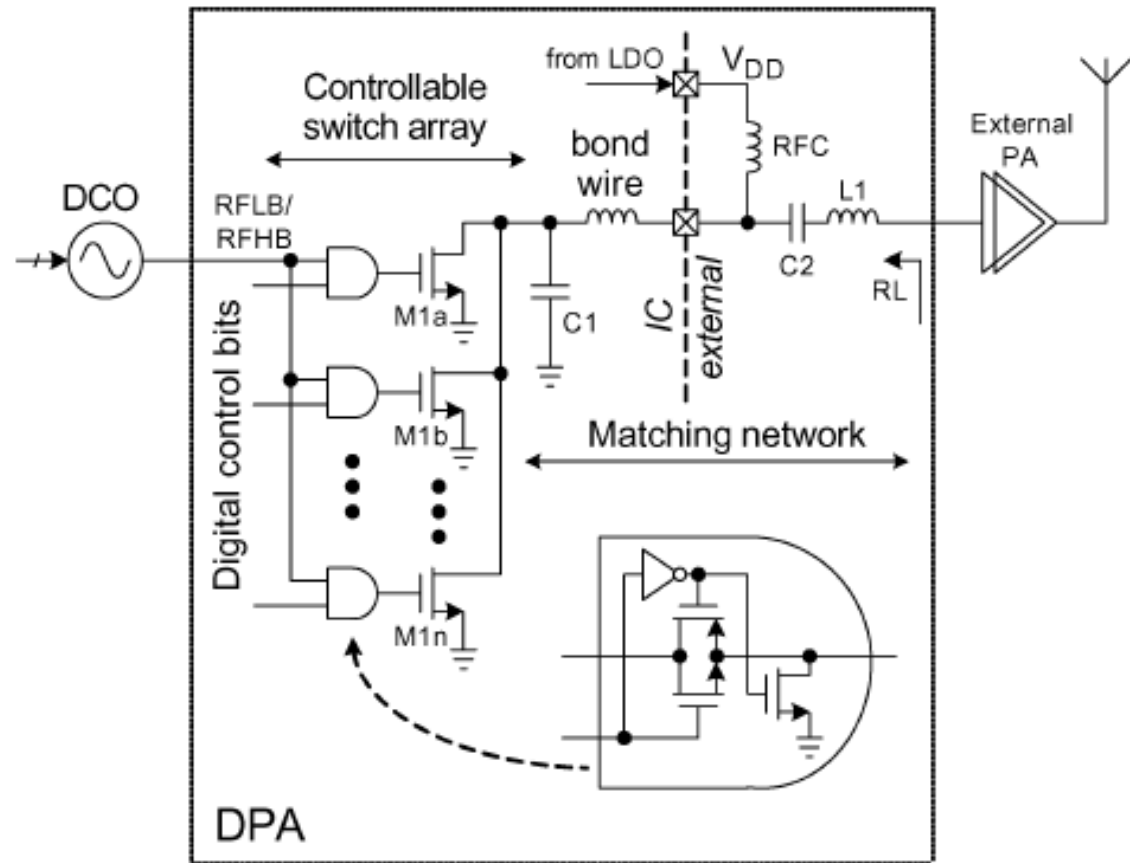

Polar Transmitter Based on APLL

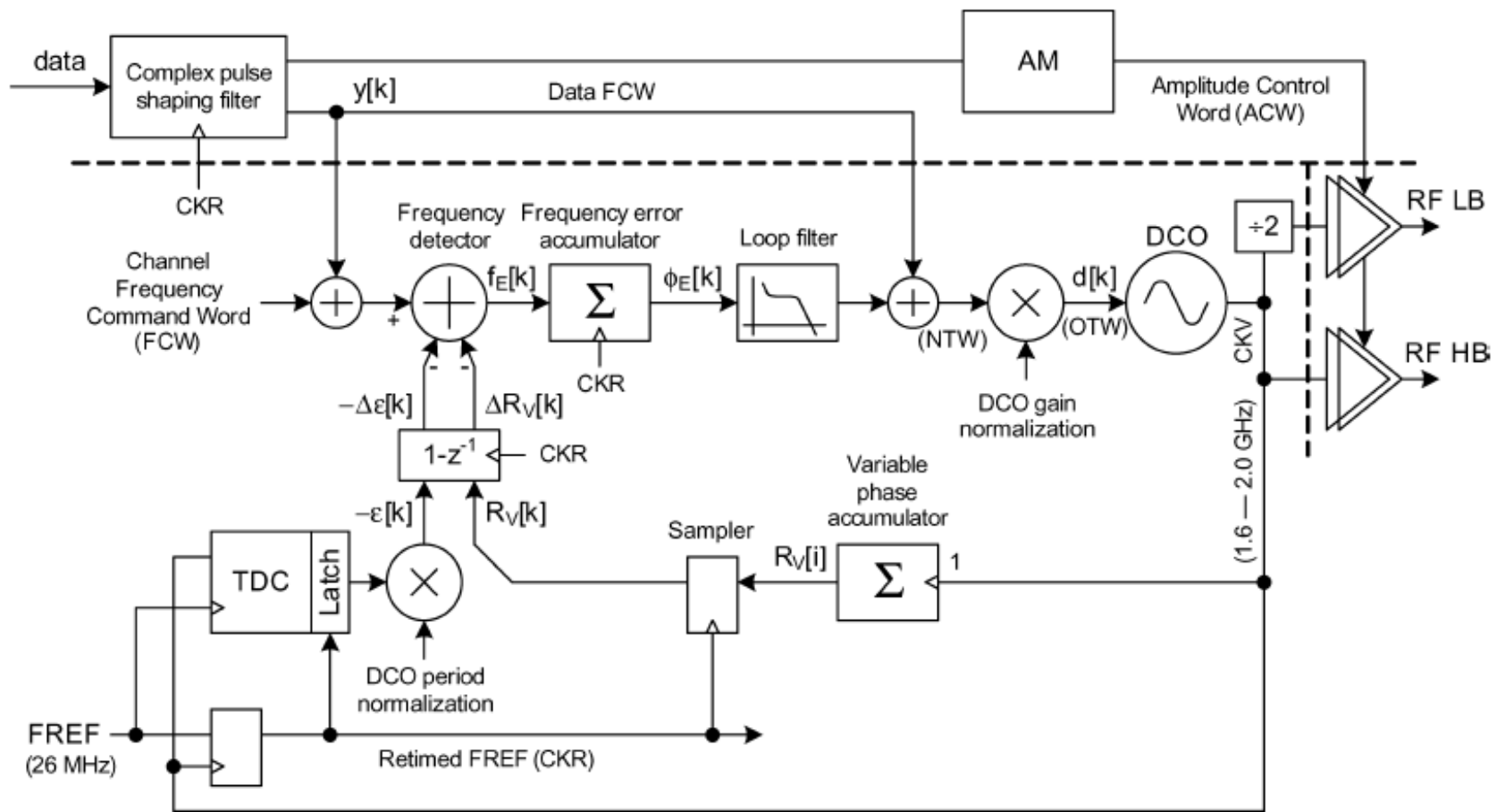

Z-Domain Model of ADPLL

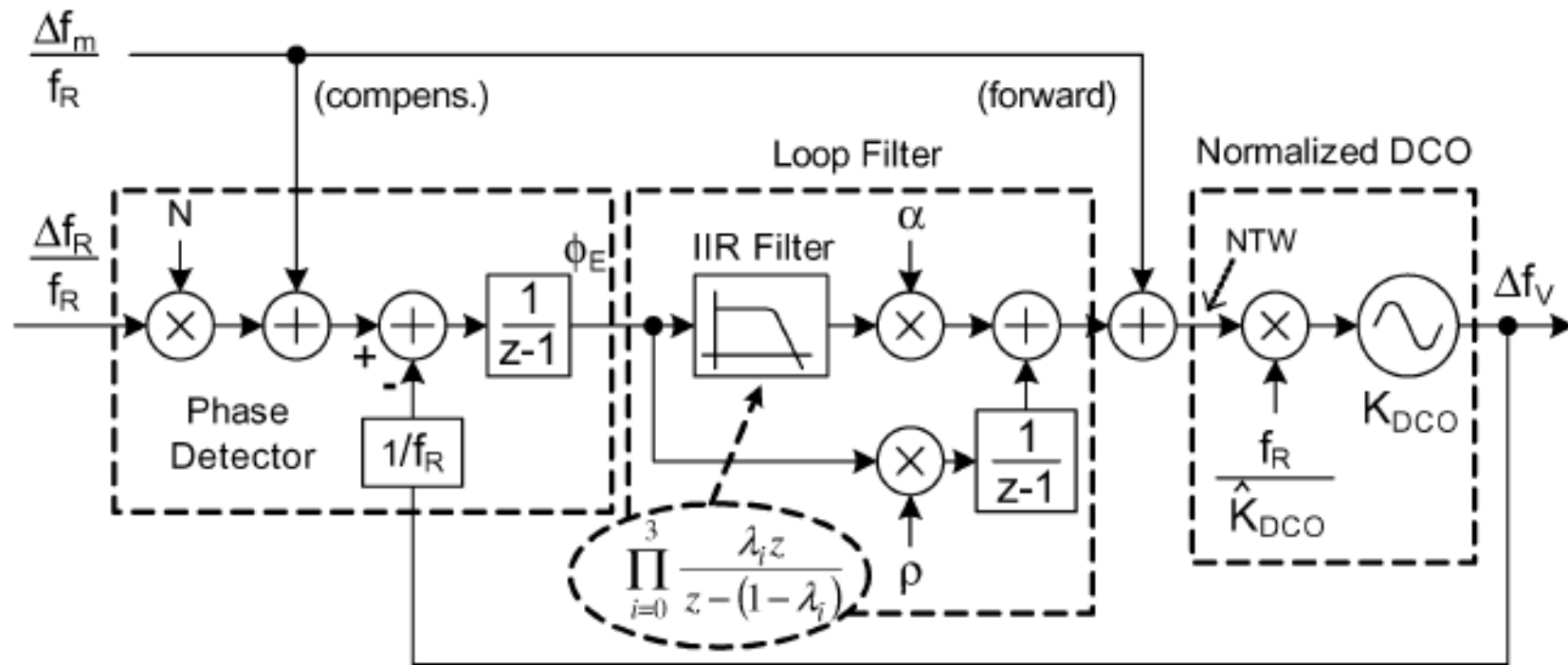

Amplitude Modulation Path

- DAC segmentation, unit element and $\Sigma\Delta$.
- DEM (bank of 8) used in unit element to improve time-averaged linearity.

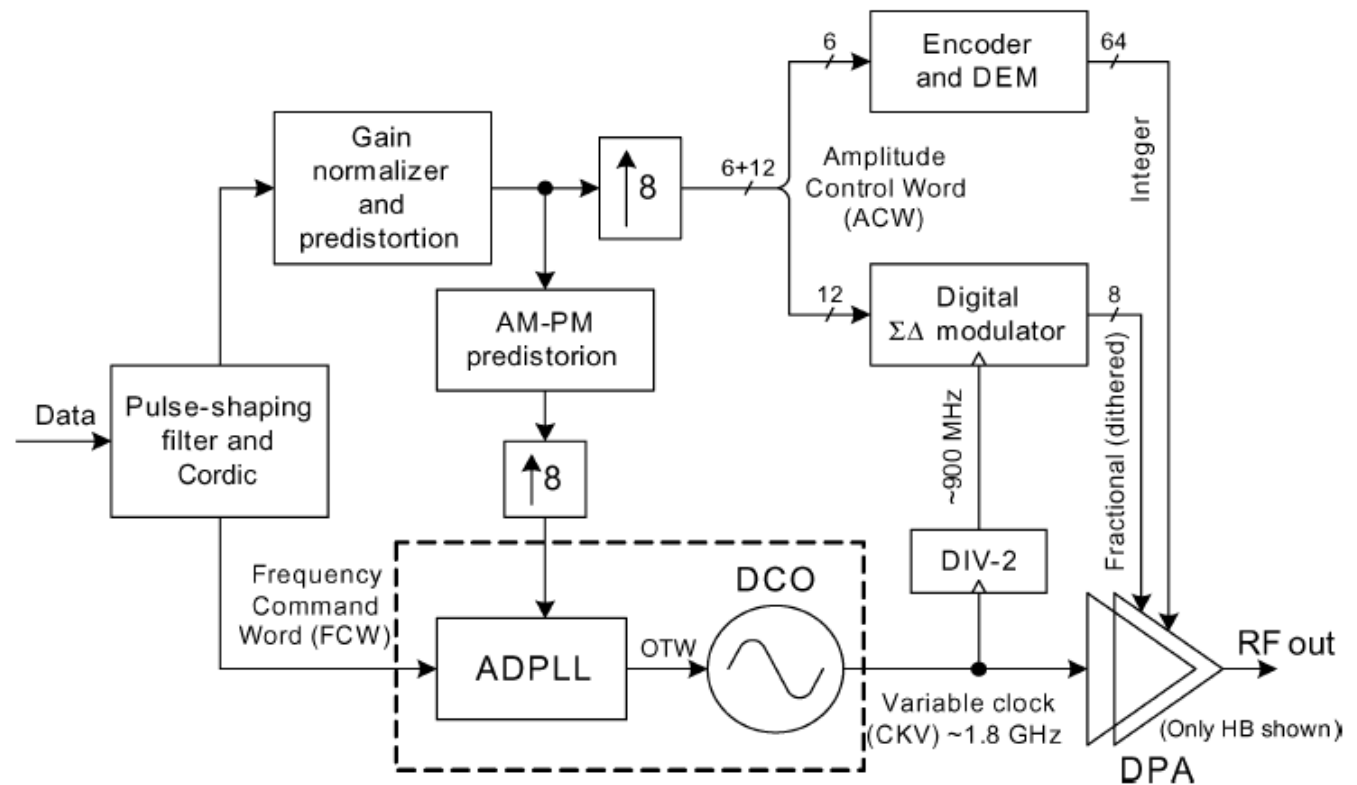

Measured Output Spectrums

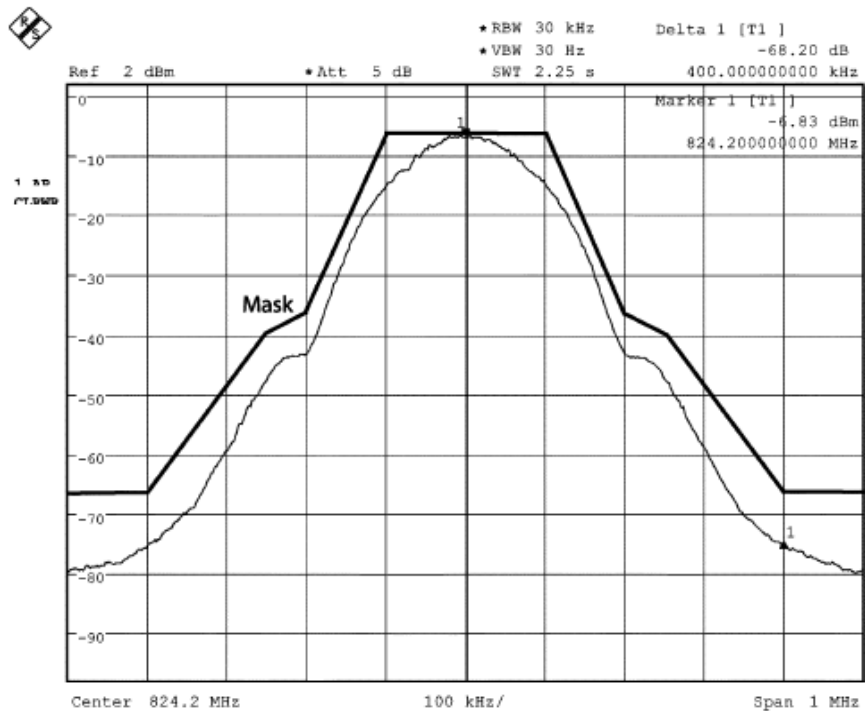

Fig. 18. Measured GSM output spectrum.

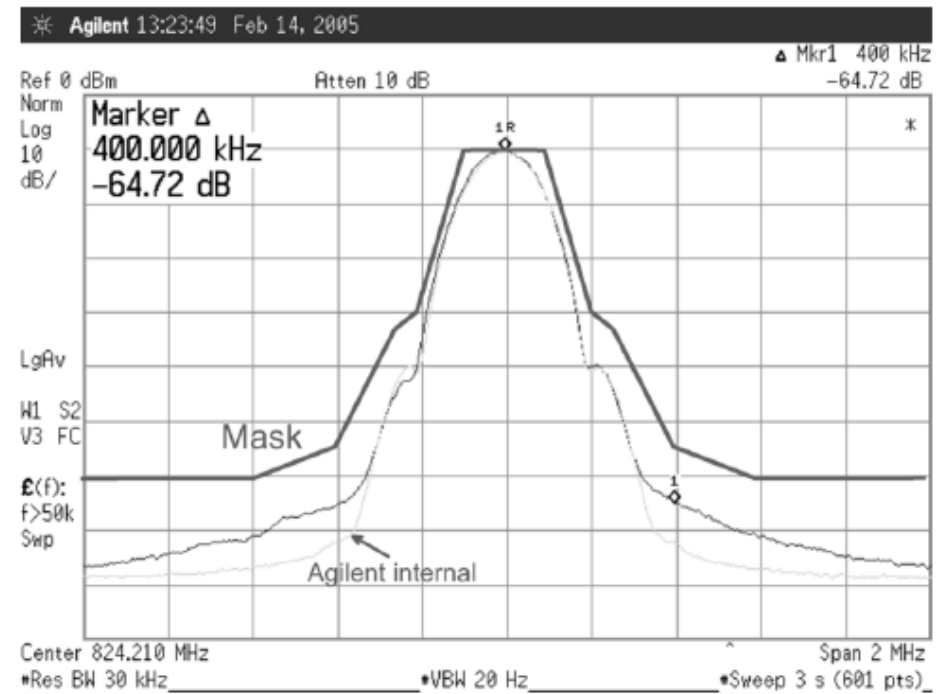
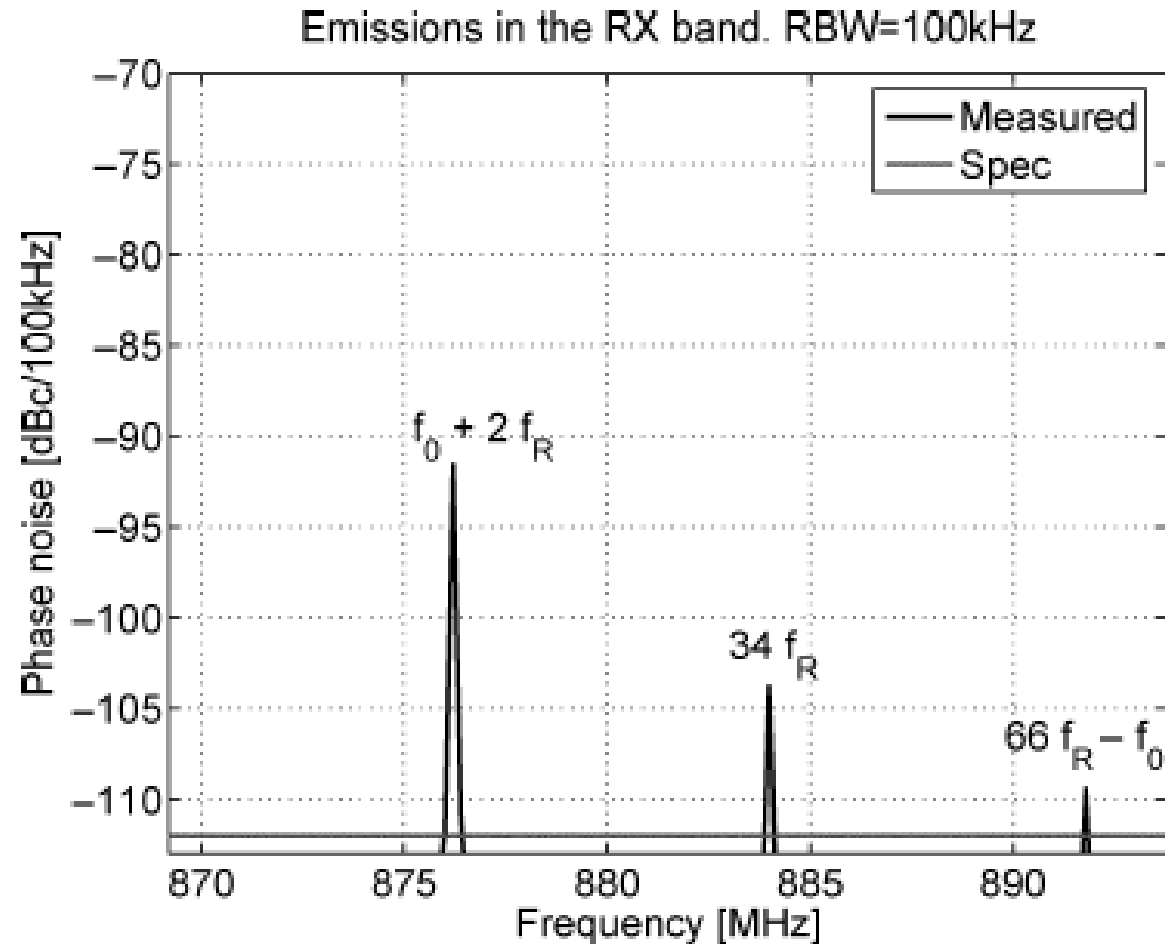

Fig. 20. Measured EDGE output spectrum.

Spectrum Spurs

- $34 f_R$ is a clock harmonic
- $f_0 + 2f_R$ is second clock harmonic modulated by the DCO
- $66f_R - f_0$ is the mixing product of the previous spurs.



Lab 2

- Proposed your own predistortion technique capable of compensating the following transmitter non-idealities in your $\Sigma\Delta$ modulator and transmitter:
 - Offset, phase and gain mismatches in the mixers
 - Gain, offset and DNL errors in the Digital-to-RF Converter.
 - Non-linearities in the mixer and PA
 - Quantization noise aliasing
 - Memory in the PA (assume one clock cycle memory only)
- The technique should be fully adaptive. If your technique assumes some parameter modeling, it should be clearly stated how the adaptive technique is capable of learning the model parameters.
- Provide a report that explains the modeling of transmitter non-idealities and the principles of the adaptive predistortion technique.
- Provide simulations showing the effectiveness of your technique in compensating the non-idealities. Use the same transmitter specs proposed in Lab 1.
- Explain the impact of non-idealities in the feedback sensing circuits and provide ideas on how you can compensate for these problems.
- If you are using any idea from a paper, please provide the corresponding reference.
- Clearly indicate which are your contributions versus the ideas used from the references.

Lab 2 (cont...)

- For the evaluation of your predistortion technique, please drive the TX with a 64 QAM constellation with a max amplitude of 1 in both I&Q components.
- Provide plots of the constellation sensed by the receiver without any non-idealities and with the non-idealities before predistortion and after predistortion. Also provide the EVM in dB in each case (see http://en.wikipedia.org/wiki/Error_vector_magnitude). Use the following values for the non-idealities.
 - Offset (-4% of your full swing), phase (1° of I mixer with respect to Q mixer) and gain (+3 %) mismatches in the mixers.
- For the Digital-to-RF Converter, assume that the 3-bit D/A converter was designed for an ideal LSB level of 100 mV. The following output voltages levels were measured for the real D/A for three codes 000 to 111 respectively: -0.01V 0.105V 0.195V 0.28V 0.37V 0.48V 0.6V 0.75V.
- Non-linearities in the mixer and PA are $f(x) = a_0 + a_1x + a_2x^2 + a_3x^3 + a_4x^4 + a_5x^5$.
 $a_0 = 0, a_1 = 1, a_2 = 1/6, a_3 = 1/9, a_4 = 1/12, a_5 = 1/15$
- Memory in the PA is 2% of previous sample.

Digital Calibration of Transmitter Non-Idealities

Transmitter Nonidealities

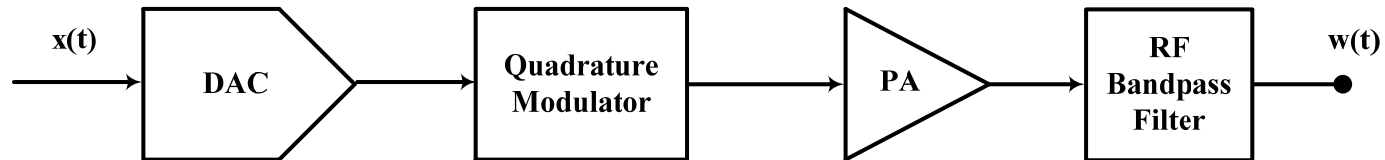

Errors in Transmitter

- Base band nonlinearities (DACs)
- Gain and phase mismatches (Mixers)
- Nonlinearities and memory effects (Power amplifiers)

Problems

- Spectral re-growth
- In band distortion

Digital Calibration [1-10]

- Objective

Build a nonlinear digital filter that adaptively predistort the baseband signal to minimize the transmitter errors

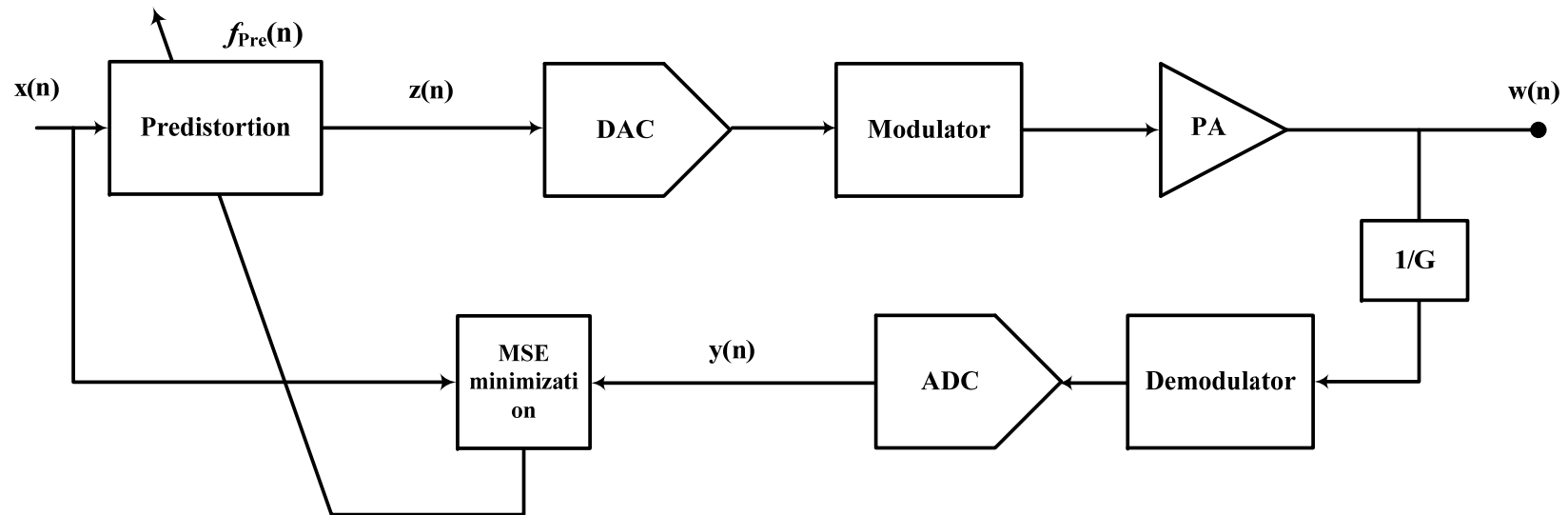

Digital Calibration

Three approaches

1) Predistortion [7,8]

First model these errors then get the inverse function that can compensate for these error. However this is a difficult task.

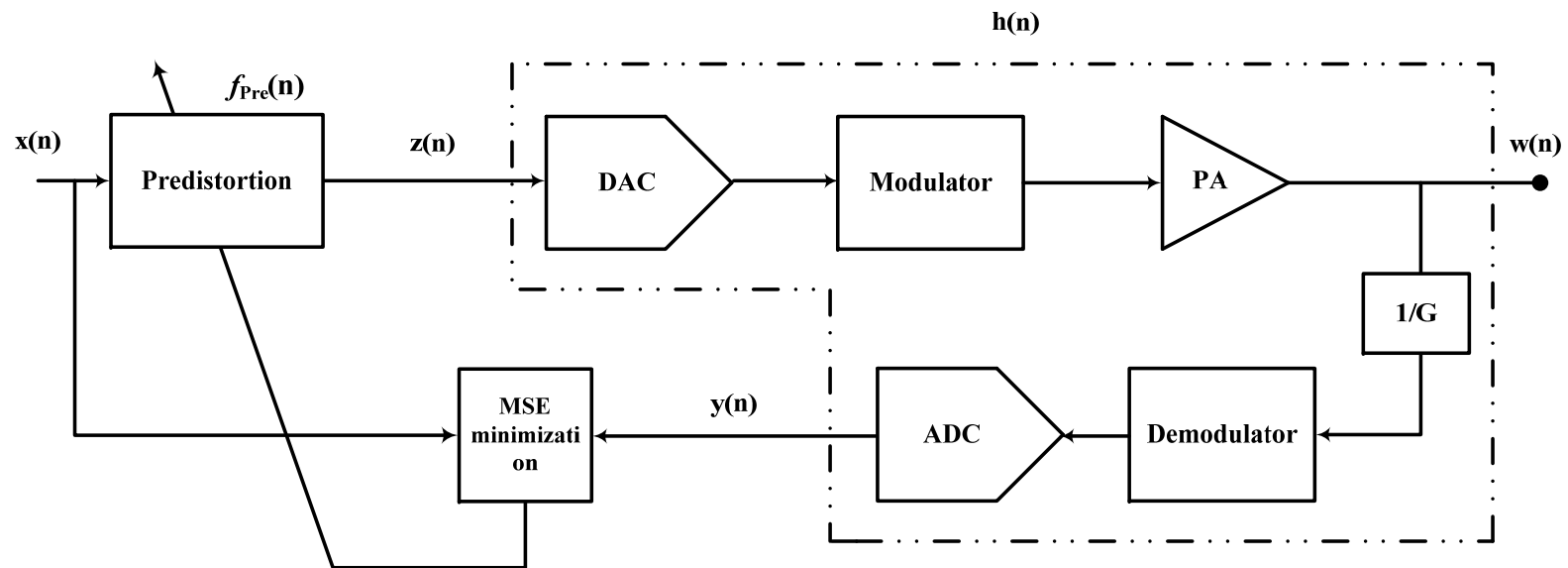

Predistortion

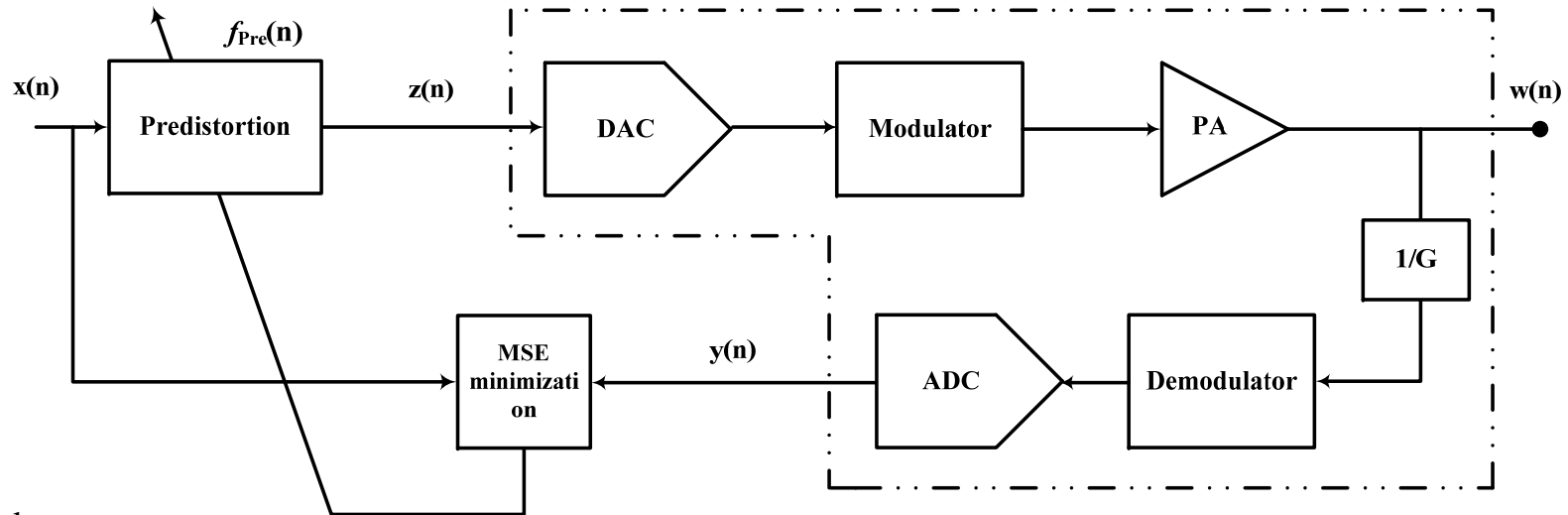

Example

$$J = E\{|x(n) - y(n)|^2\} = E\{|x(n) - h(z(n))|^2\} \quad \text{where } J \text{ is the MSE function}$$

$h(n)$ is a nonlinear system so let $y(n) = h(z(n)) = (b_1 z + b_3 z^3)$

$$J = E\{|x(n) - (b_1 z(n) + b_3 z^3(n))|^2\}$$

Let the predistortion function $z(n) = f_{pre}(x(n)) = a_1 x(n) + a_3 x^3(n)$

$$J = E\{|x(n) - (b_1(a_1 x(n) + a_3 x^3(n)) + b_3(a_1 x(n) + a_3 x^3(n))^3)|^2\}$$

unfortunately b_1 and b_3 are unknown. Moreover J become nonlinear over a_1 and a_3

Defining J in such a way may lead to a non convex problem so you may stuck to local minimums

Digital Calibration

2) Postdistortion [1,2,9]

Which means calibrating the errors after the transmitter which is not our case because we need a predistorter. However its easier to be implemented

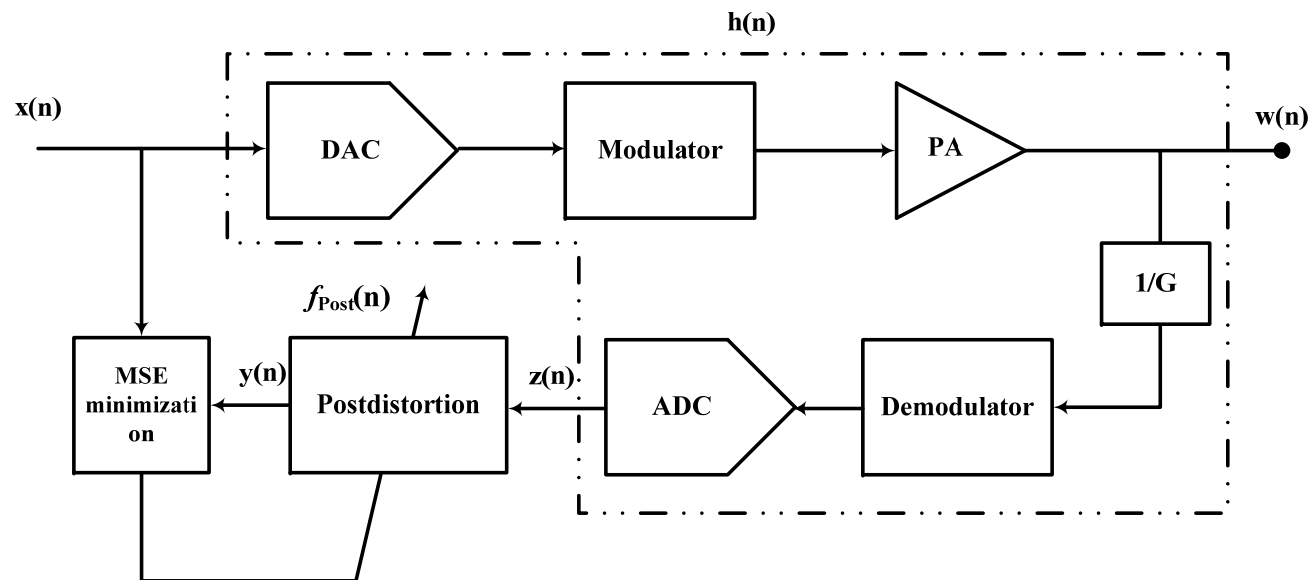

Postdistortion

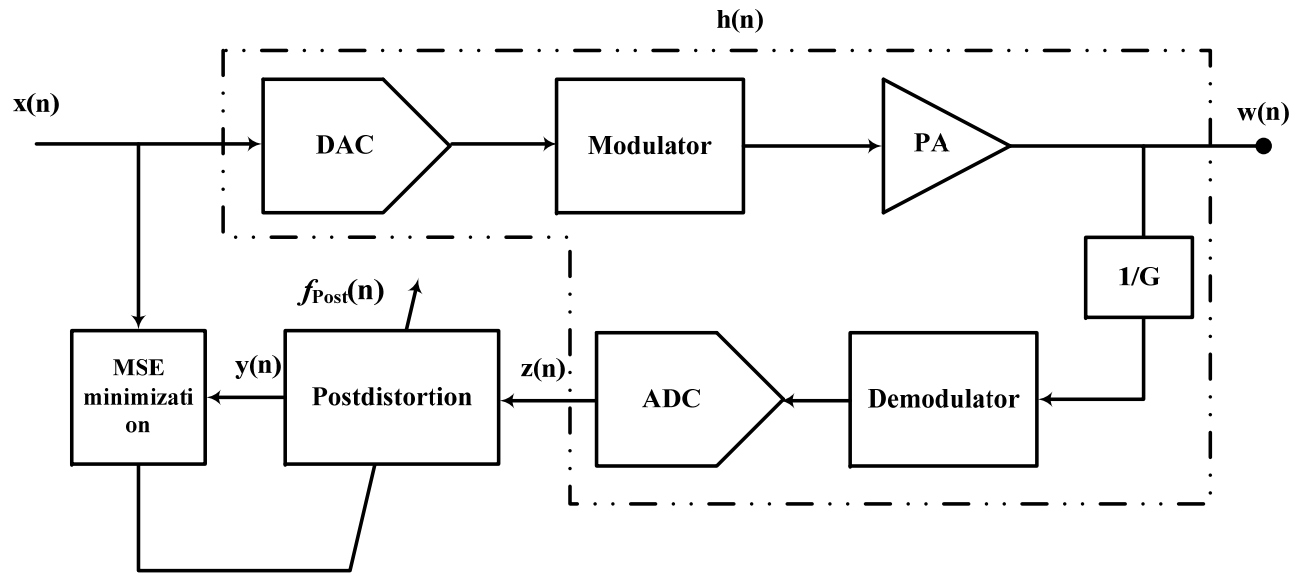

Example

$J = E\{|x(n) - y(n)|^2\} = E\{|x(n) - f(z(n))|^2\}$ where J is the MSE function

Let the postdistortion function $y(n) = f(z(n)) = (a_1 z + a_3 z^3)$

$J = E\{|x(n) - (a_1 z(n) + a_3 z^3(n))|^2\}$

J here is a linear function over a_1 and a_3 then its convex function

Here you needn't know $h(n)$ but unfortunately you can't put the postdistorter as a predistorter because they are nonlinear functions

Digital Calibration

3) Pre-Postdistortion [4,5,6,10]

Use the indirect learning architecture to design the predistorter directly. The advantage of this type of approaches is that it eliminates the need for model assumption and parameter estimation

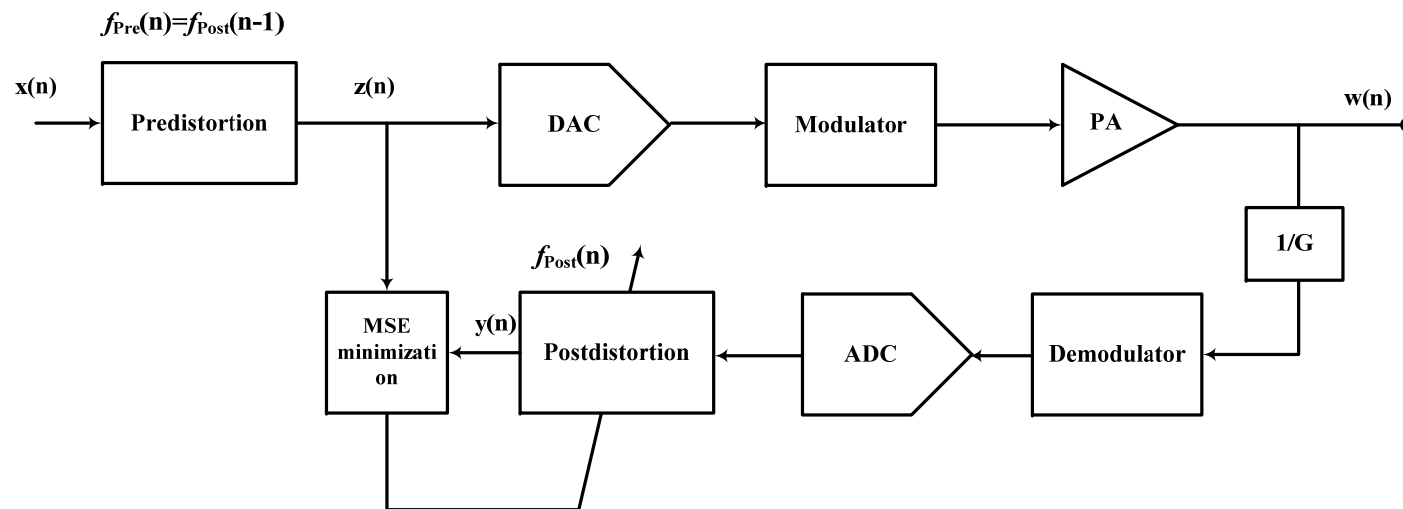

Pre-Postdistortion

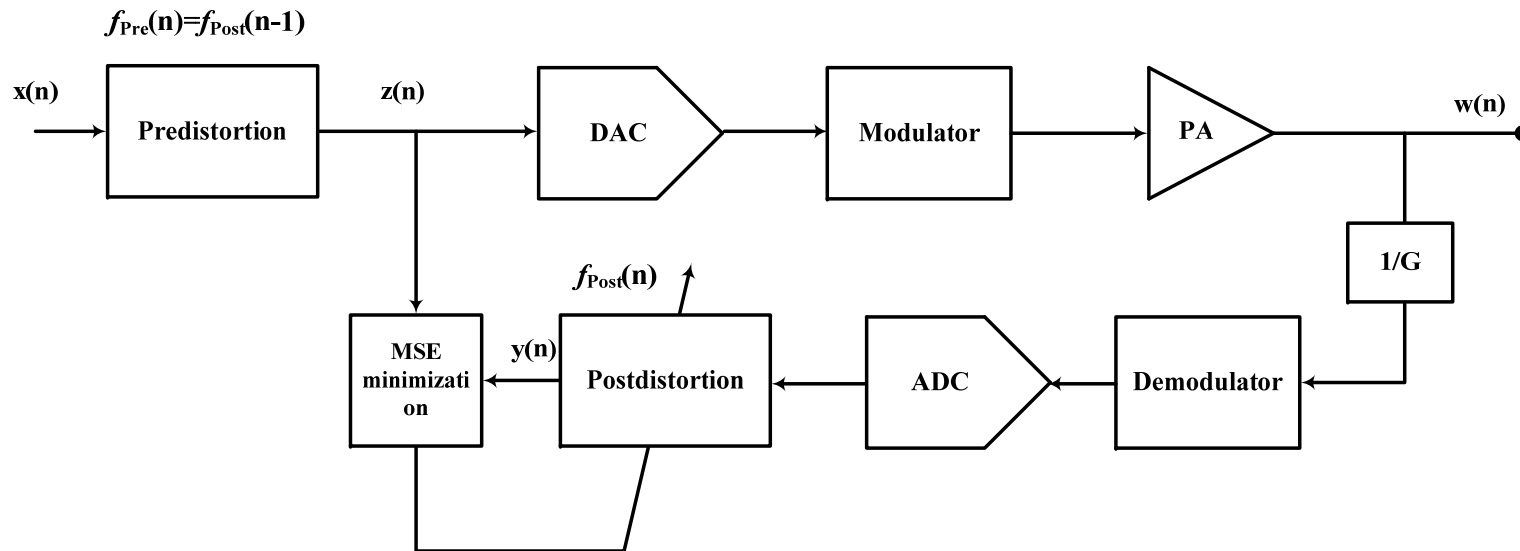

1-Initially $z(0)=x(0)$

2-The postdistorter is then designed using the MSE between $y(0)$ and $z(0)$

3-In the next iteration $F_{pre}(1)=F_{post}(0)$

4-The postdistorter is then redesigned using the MSE between $y(1)$ and $z(1)$

5-The system converge such that $f_{post} = f_{pre}$ at steady state

Pre-Postdistortion (quadrature Transceiver)

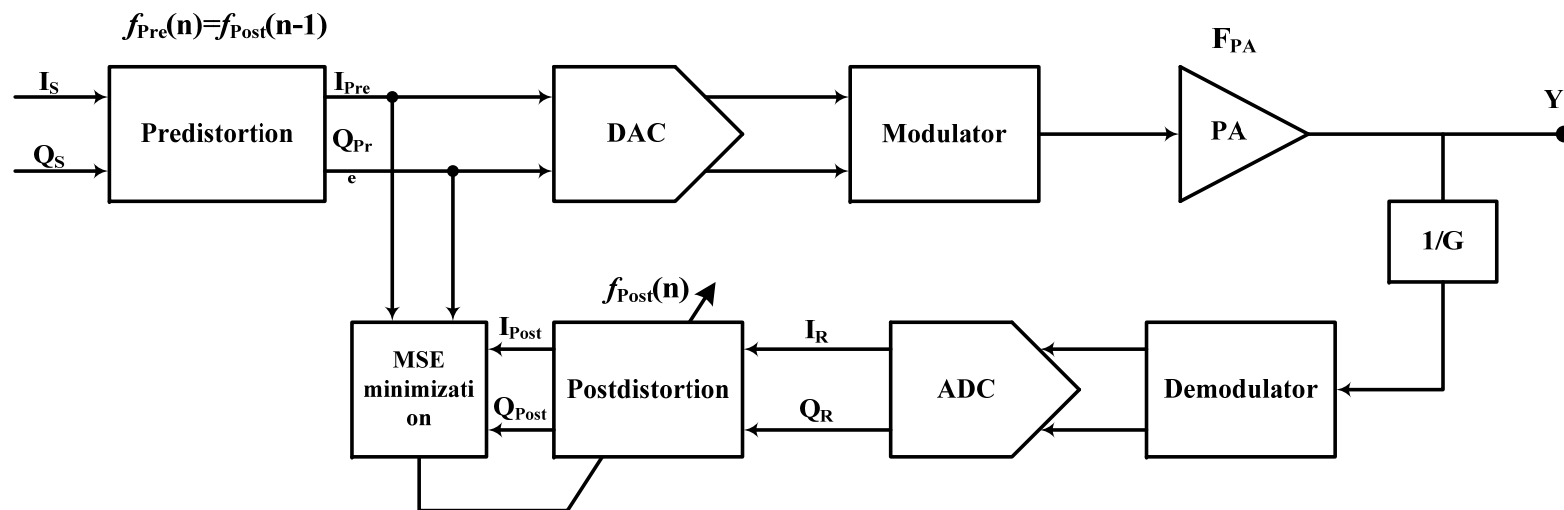

Postdistortion Design

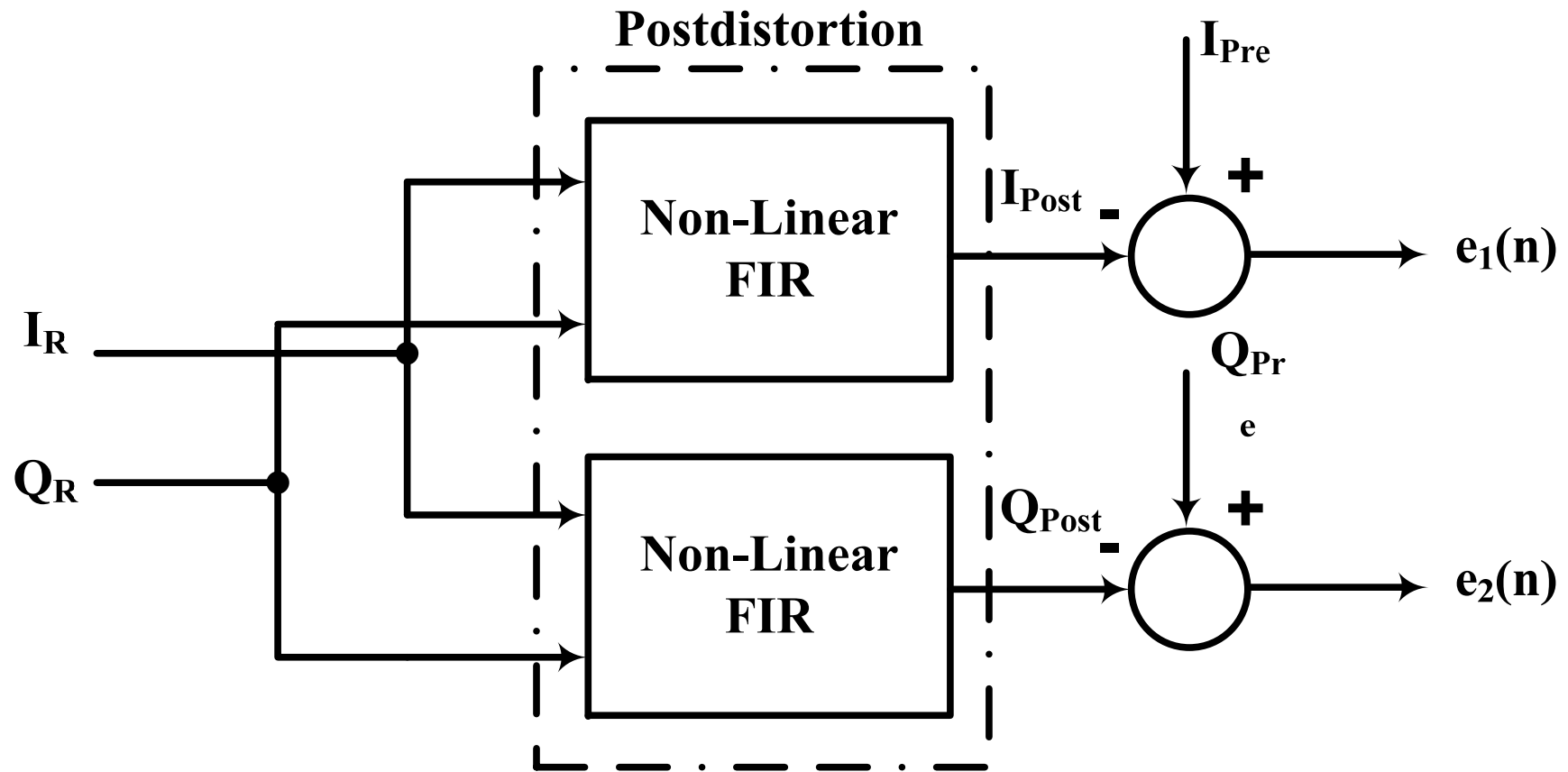

Postdistortion Design

$$I_{Post}(n) = \sum_{m=0}^{M-1} \left[\sum_{k=0}^K a_{m,2k+1} I_R(n-m)^{2k+1} + b_{m,2k+1} Q_R(n-m)^{2k+1} \right. \\ \left. + \sum_{k=1}^K \sum_{r=1}^{2k} c_{m,k,r} I_R(n-m)^r Q_R(n-m)^{2k+1-r} \right]$$

$$Q_{Post}(n) = \sum_{m=0}^{M-1} \left[\sum_{k=0}^K a'_{m,2k+1} I_R(n-m)^{2k+1} + b'_{m,2k+1} Q_R(n-m)^{2k+1} \right. \\ \left. + \sum_{k=1}^K \sum_{r=1}^{2k} c'_{m,k,r} I_R(n-m)^r Q_R(n-m)^{2k+1-r} \right]$$

Postdistortion Design

$$I_{Post}(n) = \sum_{m=0}^{M-1} \left[\mathbf{a}_m^H \mathbf{I}_{Rm} + \mathbf{b}_m^H \mathbf{Q}_{Rm} + \sum_{k=1}^{2K+1} \mathbf{c}_{2k+1,m}^H \mathbf{Y}_{2k+1,m} \right]$$

Where

$$\mathbf{a}_m^T = [a_{m,1}, a_{m,3}, \dots, a_{m,2K+1}]$$

$$\mathbf{I}_{Rm}^T = [I_R(n-m), I_R(n-m)^3, \dots, I_R(n-m)^{2K+1}]$$

$$\mathbf{b}_m^T = [b_{m,1}, b_{m,3}, \dots, b_{m,2K+1}]$$

$$\mathbf{Q}_{Rm}^T = [Q_R(n-m), Q_R(n-m)^3, \dots, Q_R(n-m)^{2K+1}]$$

$$\mathbf{c}_{2k+1,m}^T = [c_{m,1,2k}, c_{m,2,2k-1}, \dots, c_{m,2k,1}]$$

$$\mathbf{Y}_{2k+1,m}^T = [I_R(n-m)Q_R(n-m)^{2k}, I_R(n-m)^2Q_R(n-m)^{2k-1}, \dots, I_R(n-m)^{2k}Q_R(n-m)]$$

Let $\mathbf{X}^T(n) = [\mathbf{I}_{R0}, \dots, \mathbf{I}_{RM-1}, \mathbf{Q}_{R0}, \dots, \mathbf{Q}_{RM-1}, \mathbf{Y}_{3,0}, \dots, \mathbf{Y}_{2K+1,0}, \dots, \mathbf{Y}_{3,M-1}, \dots, \mathbf{Y}_{2K+1,M-1}]$

And $\mathbf{w}_I^T = [\mathbf{a}_0, \dots, \mathbf{a}_{M-1}, \mathbf{b}_0, \dots, \mathbf{b}_{M-1}, \mathbf{c}_{3,0}, \dots, \mathbf{c}_{2K+1,0}, \dots, \mathbf{c}_{3,M-1}, \dots, \mathbf{c}_{2K+1,M-1}]$

Then $I_{Post}(n) = \mathbf{w}_I^H \mathbf{X}(n)$

The error now can be written as

$$e_1(n) = I_{Pre}(n) - I_{Post}(n) = I_{Pre}(n) - \mathbf{w}_I^H \mathbf{X}(n)$$

Postdistortion Design

The objective function is chosen as the mean squared-error (MSE)

$$J_1(\mathbf{w}_I) = E \left\{ |e_1(n)|^2 \right\} = E \left\{ e_1(n) e_1^*(n) \right\}$$

The \mathbf{w}_I that minimize $J_1(\mathbf{w}_I)$ is the optimal filter weights

$$e_1(n) = I_{Pre}(n) - I_{Post}(n) = I_{Pre}(n) - \mathbf{w}_I^H \mathbf{X}(n)$$

$$J_1(\mathbf{w}_I) = E \left\{ \left(I_{Pre}(n) - \mathbf{w}_I^H \mathbf{X}(n) \right) \left(I_{Pre}^*(n) - \mathbf{X}^H(n) \mathbf{w}_I \right) \right\}$$

$$J_1(\mathbf{w}_I) = E \left\{ |I_{Pre}(n)|^2 \right\} - E \left\{ I_{Pre}(n) \mathbf{X}^H(n) \right\} \mathbf{w}_I \\ - \mathbf{w}_I^H E \left\{ \mathbf{X}(n) I_{Pre}^*(n) \right\} + \mathbf{w}_I^H E \left\{ \mathbf{X}(n) \mathbf{X}^H(n) \right\} \mathbf{w}_I$$

Let $\mathbf{R} = E \left\{ \mathbf{X}(n) \mathbf{X}^H(n) \right\}$ (autocorrelation of $\mathbf{X}(n)$)

And $\mathbf{P}_I = E \left\{ \mathbf{X}(n) I_{Pre}^*(n) \right\}$ (cross correlation between $\mathbf{X}(n)$ and $I_{Pre}(n)$)

Then $J_1(\mathbf{w}_I) = E \left\{ |I_{Pre}(n)|^2 \right\} - \mathbf{P}_I^H \mathbf{w}_I - \mathbf{w}_I^H \mathbf{P}_I + \mathbf{w}_I^H \mathbf{R} \mathbf{w}_I$

The MSE function $J_1(\mathbf{w}_I)$ is a convex function that has a unique minimum

Postdistortion Design

The optimal filter weight vector can be found by differentiating and setting this to zero

$$\nabla J_1 = 0$$

$$\nabla J_1 = -2(\mathbf{P}_I - \mathbf{R}\mathbf{w}_I) = 0$$

$$\mathbf{w}_{Iopt} = \mathbf{R}^{-1}\mathbf{P}_I$$

Similarly

$$\mathbf{w}_{Qopt} = \mathbf{R}^{-1}\mathbf{P}_Q$$

Postdistortion Design

- To reduce the complexity and memory requirements due to matrix inversion, a recursive normalized least mean square (NLMS) method is used

$$\mathbf{w}_I(n+1) = \mathbf{w}_I(n) + \frac{1}{2} \frac{\mu_I}{\|\mathbf{X}(n)\|^2} (-\nabla J_1(n))$$

$$\mathbf{w}_Q(n+1) = \mathbf{w}_Q(n) + \frac{1}{2} \frac{\mu_Q}{\|\mathbf{X}(n)\|^2} (-\nabla J_2(n))$$

Tx Model

- 10% gain mismatch and 10° phase mismatch between the inphase and quadrature mixers.
- A Wiener power amplifier model is used. The LTI portion has the a transfer function which is given by
$$H(z) = 1 + 0.2z^{-1}$$
- The coefficients of the memoryless nonlinear portion of the power amplifier model are extracted from an actual class AB power amplifier [5], $c1 = 14.9740 + 0.0519j$, $c3 = -23.0954 + 4.9680j$, and $c5 = 21.3936 + 0.4305j$ (Gain=23.52dB, OP1-dB=21.4dBm, OIP3=32.8dBm)

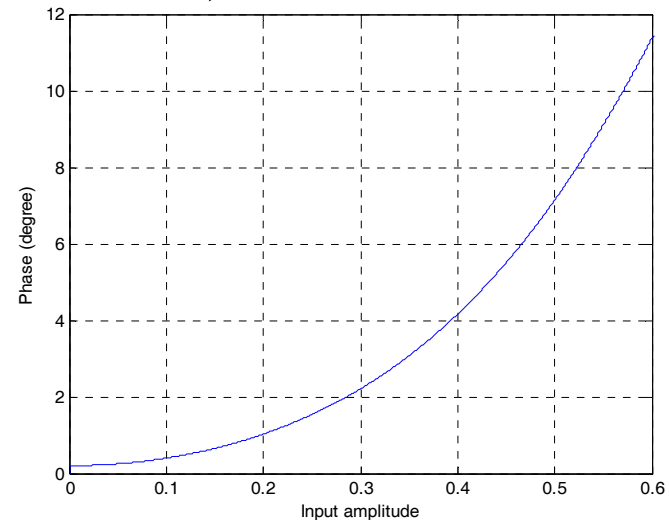
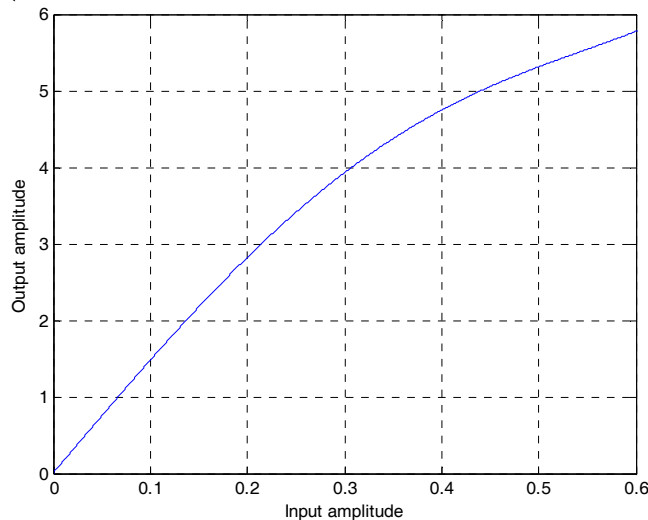

Results (64-QAM)

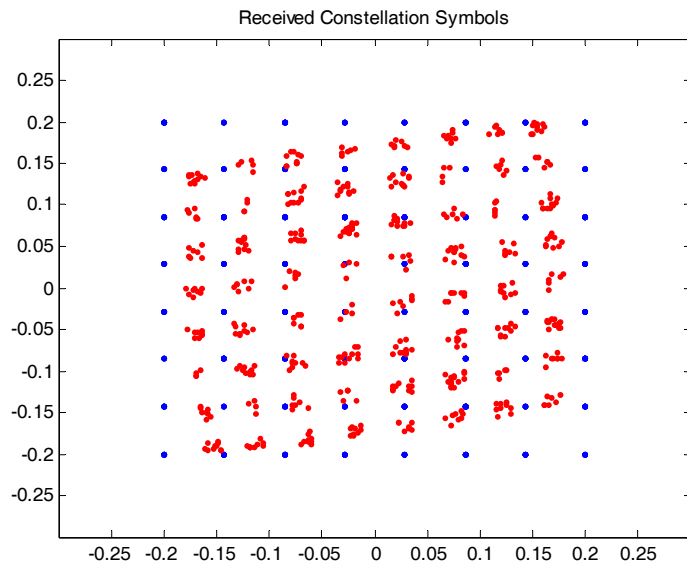
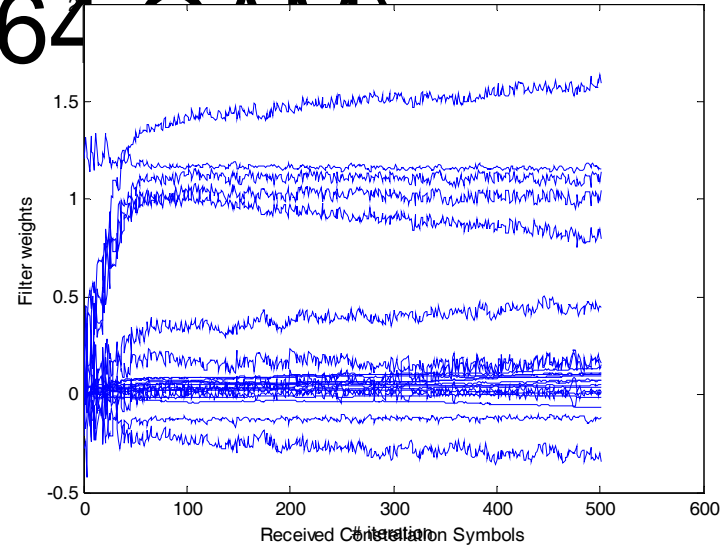

EVM=19.79 % before predistortion

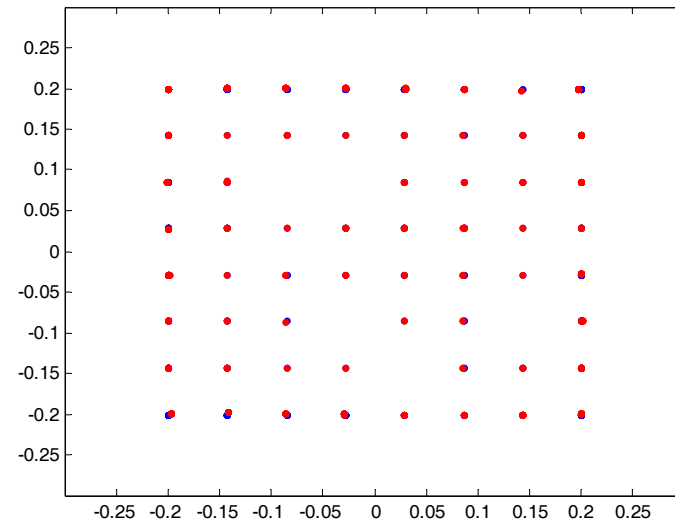

EVM=0.7 % after predistortion

Results (5 Multi-tones Input signals)

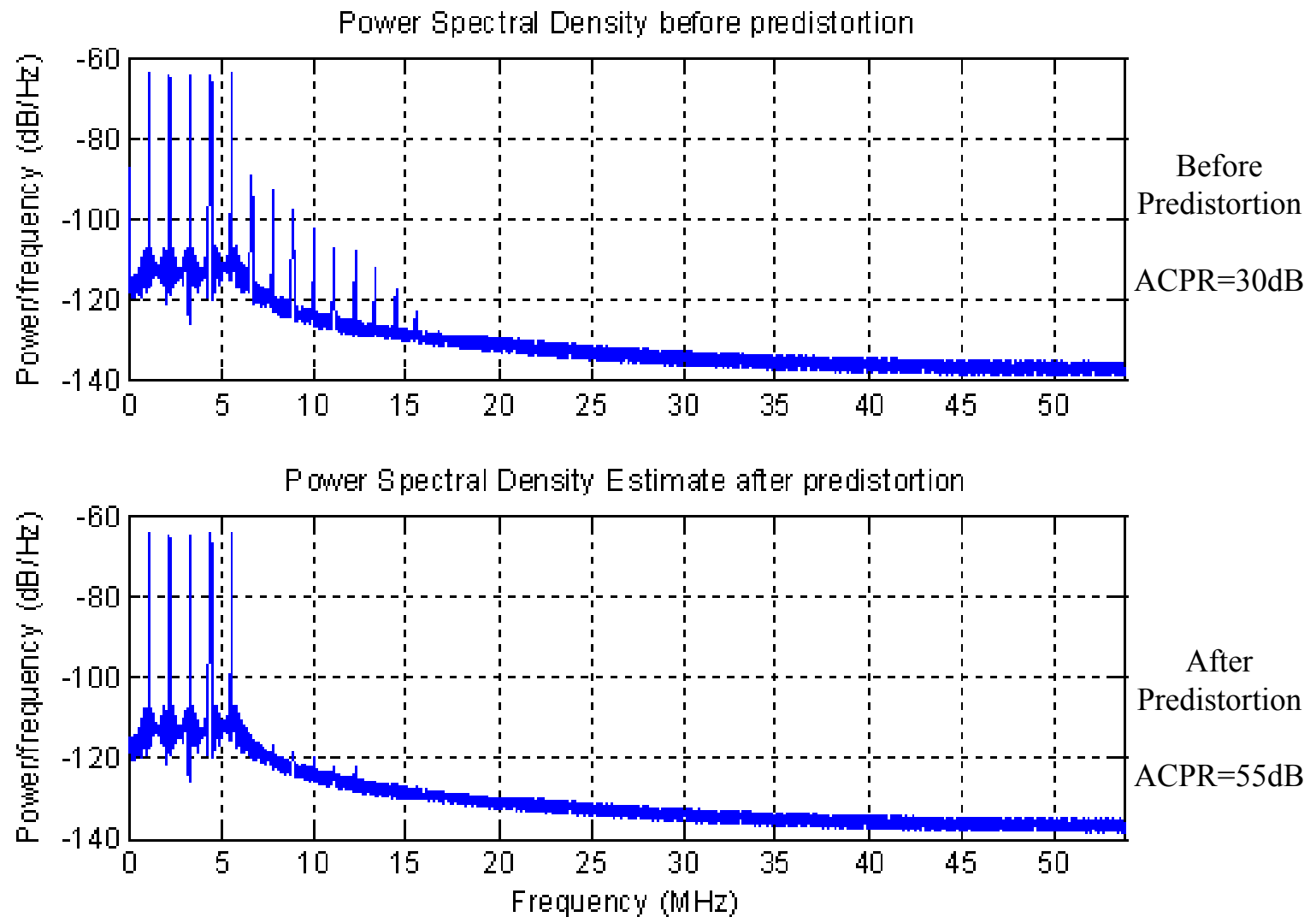

Another Approach

- To reduce the complexity requirement of the design, we can use the following model

$$y(n) = \sum_{m=0}^{M-1} \left[\sum_{k=0}^K w_{m,2k+1}^* x(n-m) |x(n-m)|^{2k} \right]$$

$$\text{where } x(n) = \alpha I_R(n) + j\beta Q_R(n)$$

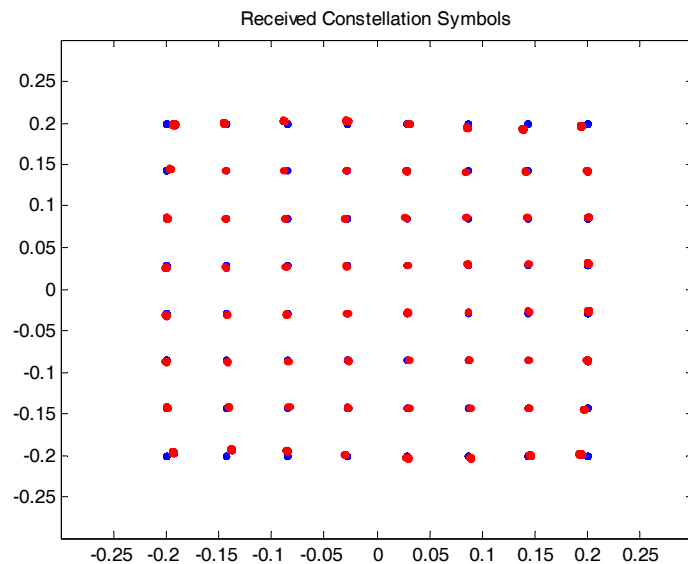

After Predistortion EVM = 2.2 %

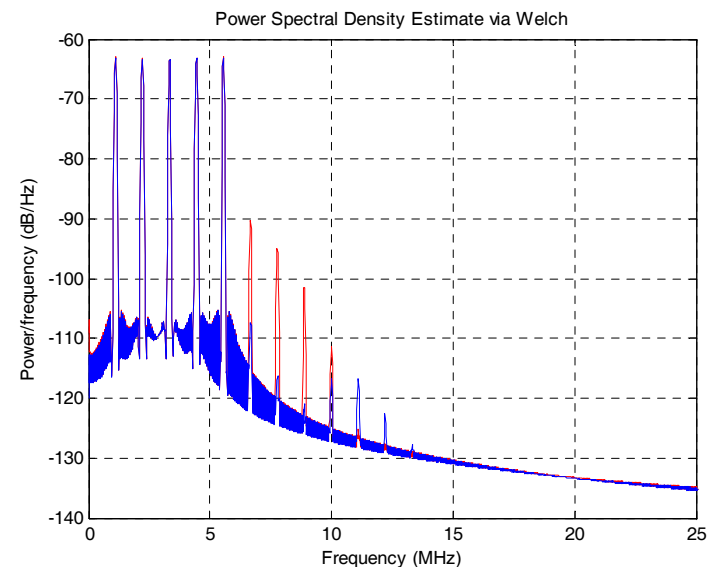

After Predistortion ACPR=50dB

Comparison

	1st approach	2nd approach
EVM (64 QAM)	0.7%	2.2%
ACPR (5 multi-tone Input signal)	55dB	50dB
Complexity for the predistorter design	48 weights	16 weights

References

[1] R. Marsalek, P. Jardin, and G. Baudoin, “From post-distortion to pre-distortion for power amplifiers linearization”, *IEEE Communications Letters*, vol. 7, no. 7, July 2003

[2] M. Ghaderi, S.Kumar, and D. E. Dodds, “Fast adaptive polynomial I and Q predistorter with global optimization,” *Proc. IEE Communications*, vol. 143, no. 2, p. 78, Apr. 1996.

[3] Seung-Yup Lee, Yong-Sub Lee, Seung-Ho Hong, Hyun-Sik Choi, and Yoon-Ha Jeong, “An Adaptive Predistortion RF Power Amplifier With a Spectrum Monitor for Multicarrier WCDMA Applications” *IEEE*

Transaction on Microwave Theory and Techniques, vol. 53, no. 2, February 2005

[4] Xu Lingjun, Wu Xiaoguang, Wang Qiang, and Zhang Ping, “Adaptive digital predistorter for radio frequency power amplifier linearization” *IEEE 2007 International Symposium on Microwave, Antenna, Propagation, and EMC Technologies For Wireless Communications*.

[5] Lei Ding, “Digital Predistortion of Power Amplifiers for Wireless Applications” PhD thesis, *Georgia Institute of Technology*, March 2004.

[6] Dongliang Huang, Henry Leung and Xinping Huang, “A rational function based predistorter for high power amplifier”, *ISCAS 2004*

[7] Ovidiu Leulescu, Tudor Petrescu, and Teodor Petrescu, “Digital filtering for power amplifiers linearization”,

References

- [8] Shanying Wu, S.F.Simon Hau, and Y.M. Wong, “The use of Nonlinear Curve fitting in Digital Predistortion for Linearizing RF Power Amplifiers” *ICICS 2005*
- [9] Pascale Jardin and Geneviève Baudoin, Filter, “Lookup Table Method for Power Amplifier Linearization” *IEEE Transaction on Vehicular Technology*, vol. 56, no. 3, May 2007
- [10] Lei Ding, Zhengxiang Ma, Dennis R. Morgan, Mike Zierdt, and John Pastalan,” A Least-Squares/Newton Method for Digital Predistortion of Wideband Signals” *IEEE Transactions on Communications*, vol. 54, no. 5, May 2006

Polyphase Multipath Transmitter Technique

*Eric A. M. Klumperink, et. al., "Polyphase Multipath Radio Circuits for Dynamic Spectrum Access,"
IEEE Communications Magazine • May 2007*

Non-linearities

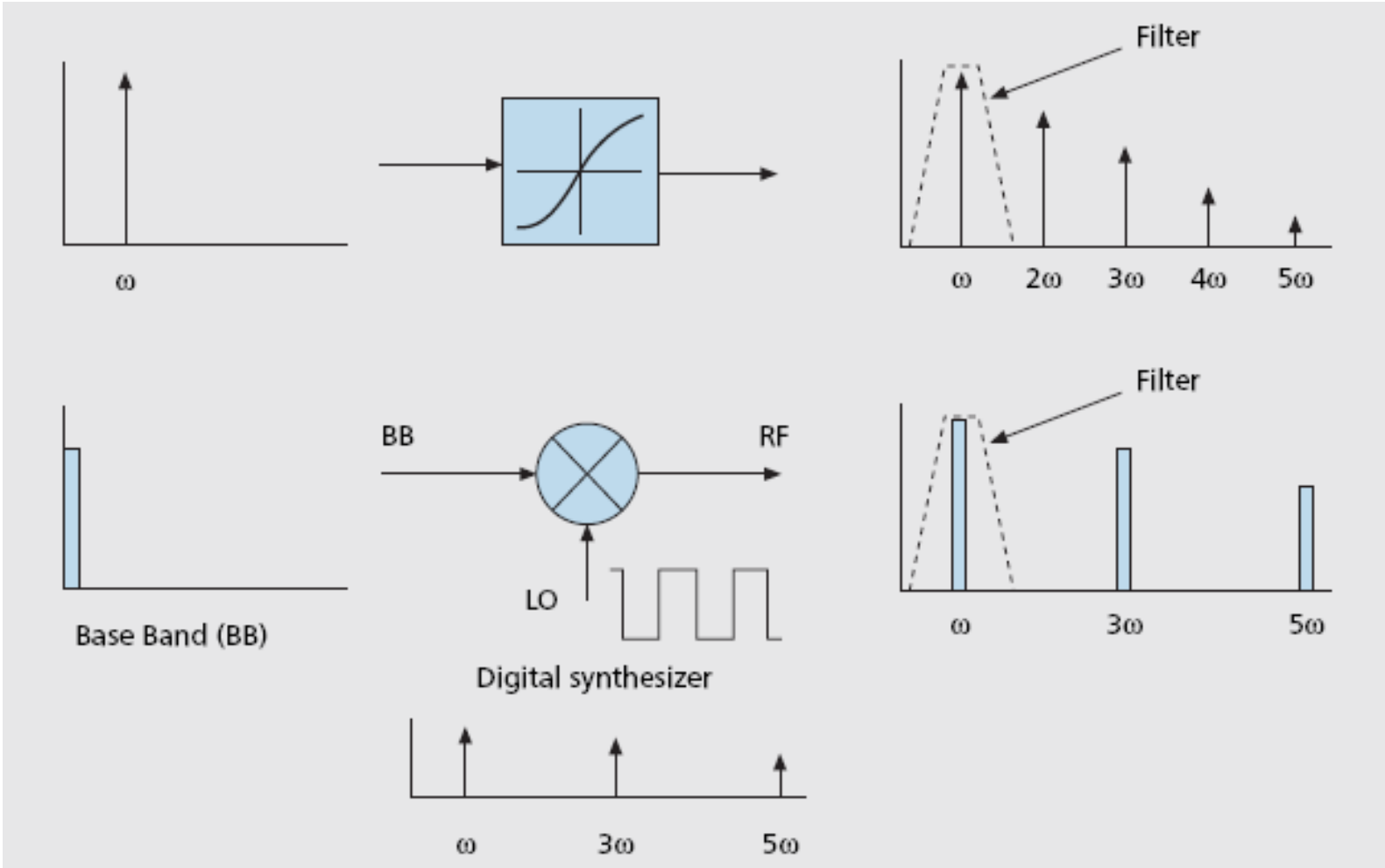

2-Path Circuit Cancelling Even Harmonics

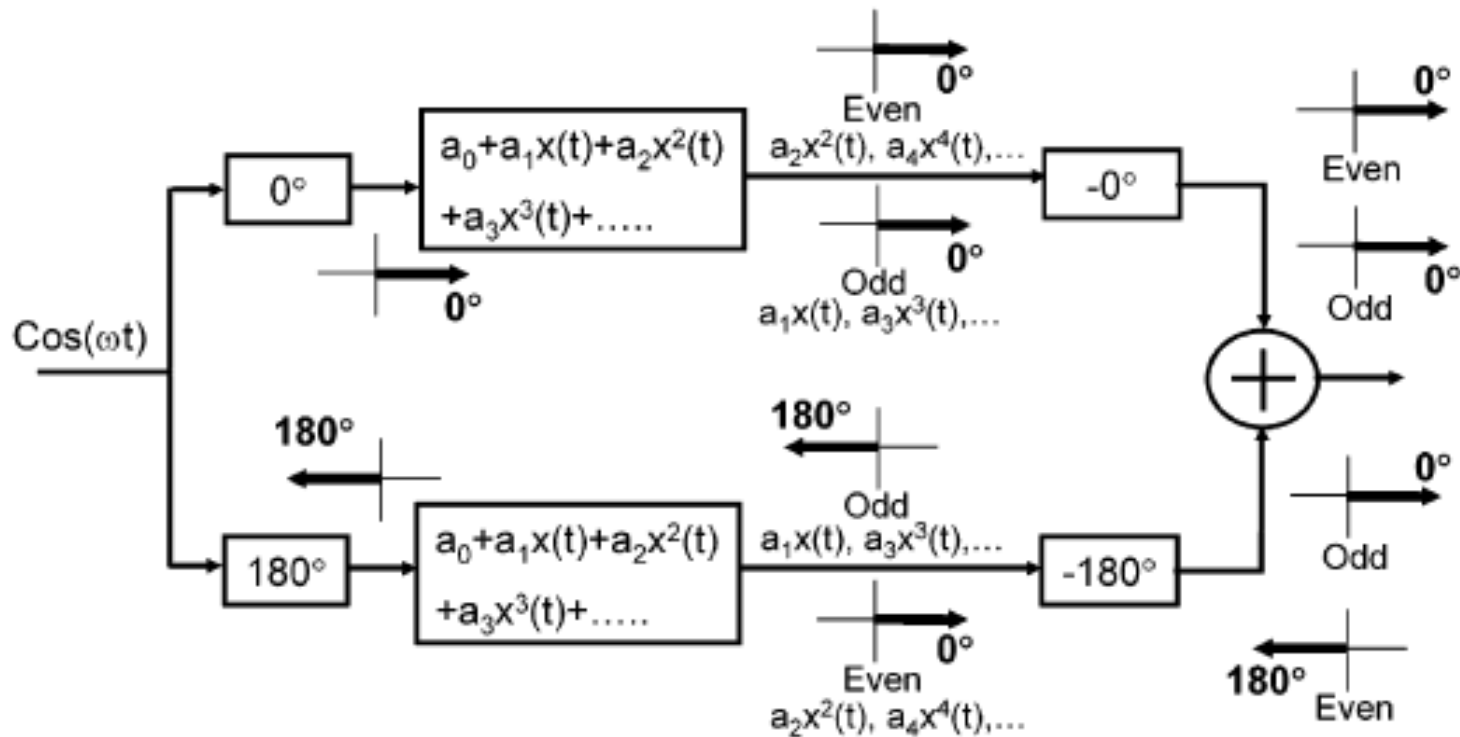

Polyphase 3-path circuit cancelling 2ω and 3ω harmonics.

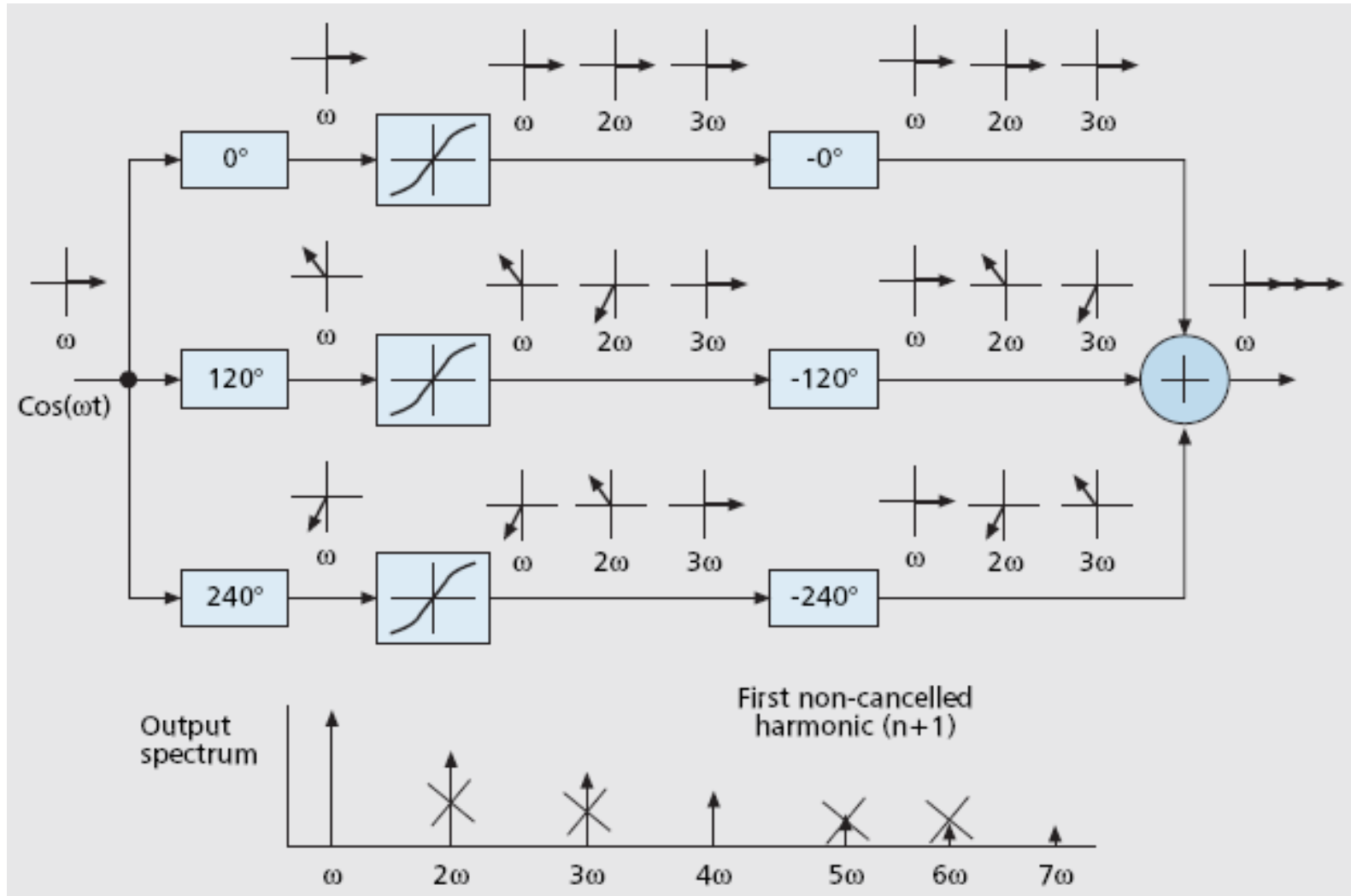

Polyphase n-path transmitter using mixers as phase shifters.

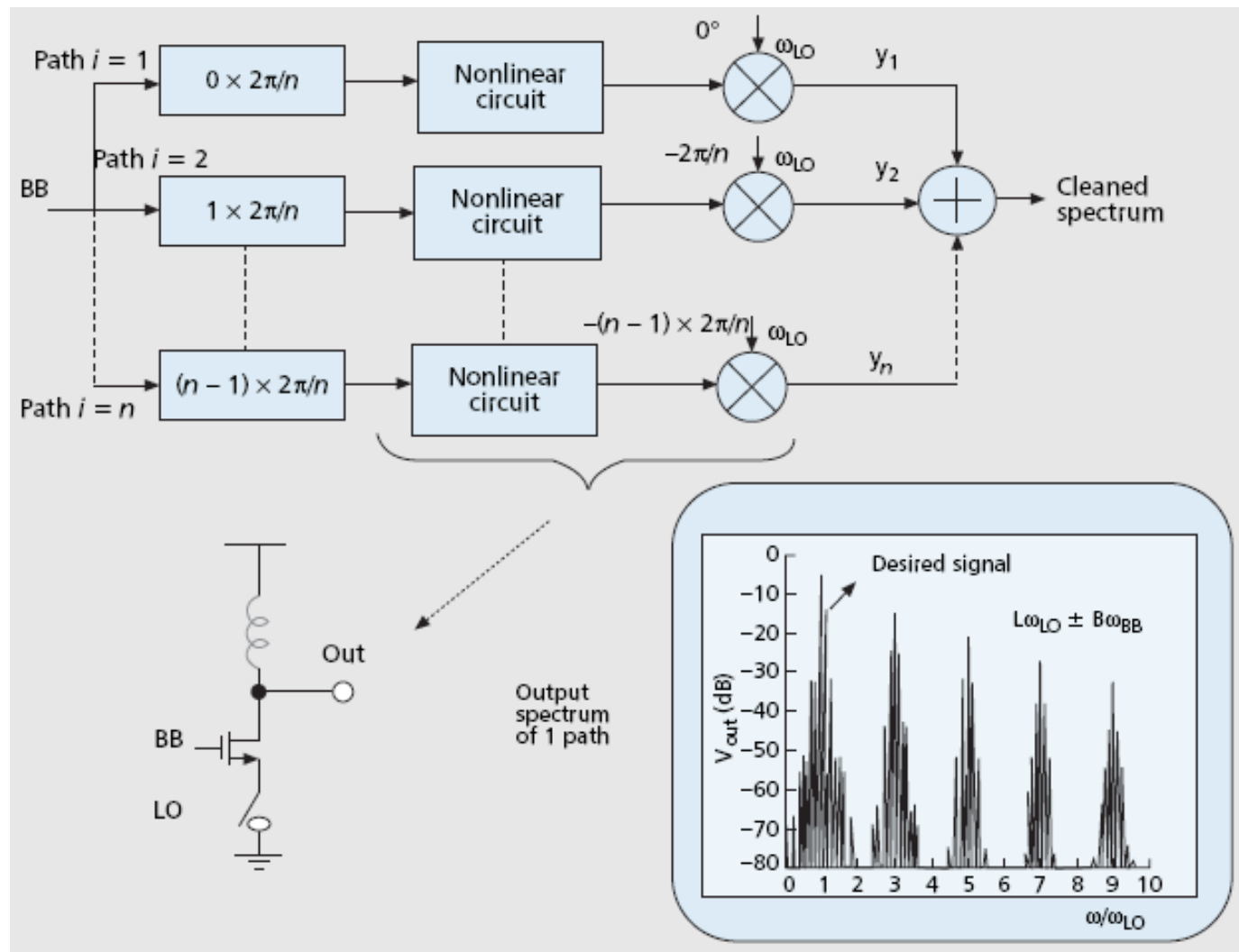

Circuit concept of an 18-path power upconverter.

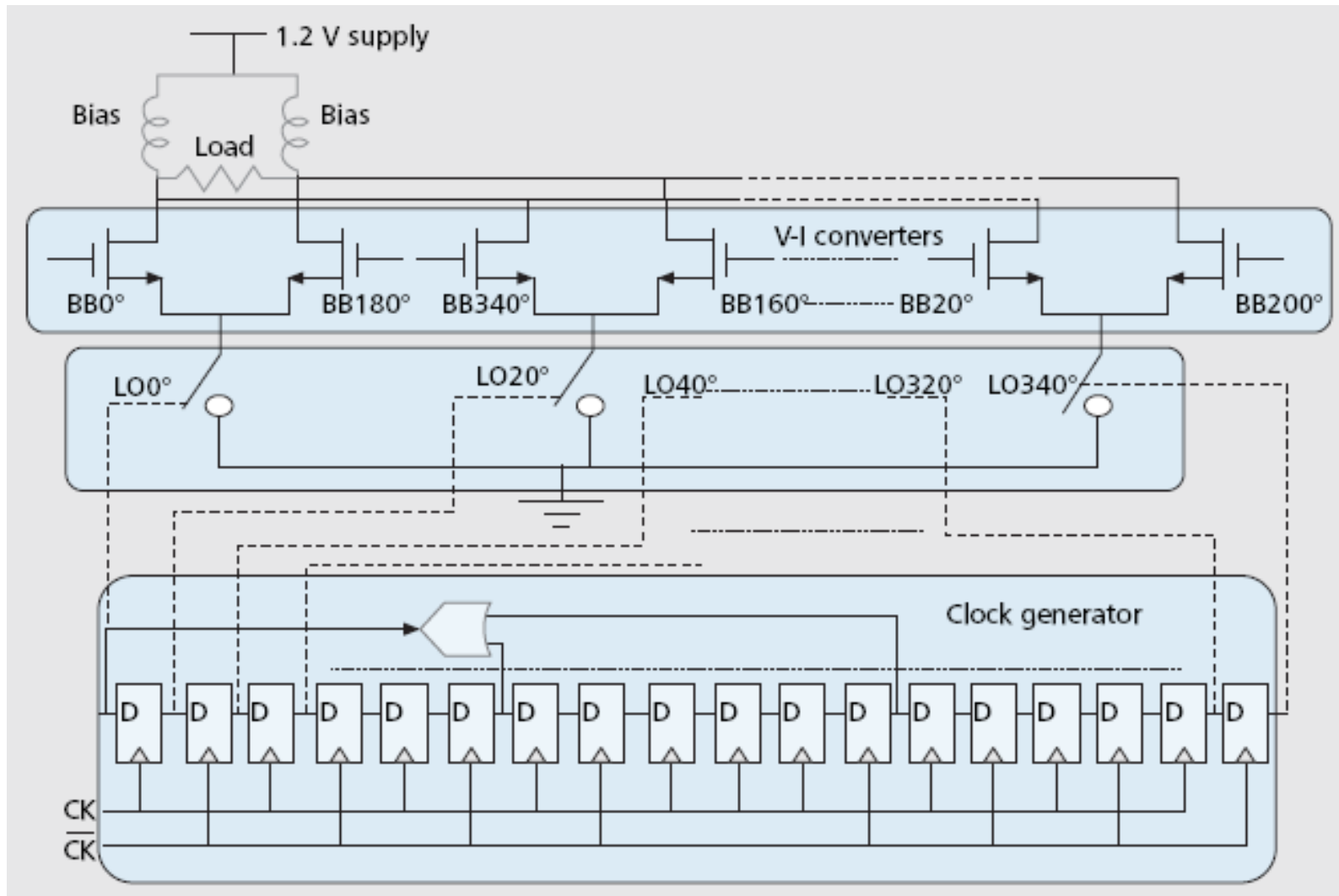

Matlab Simulations

- Single-path power upconverter has spectral components at

$$K_{LO}\omega_{LO} \pm m\omega_{BB}$$

- Non cancelled products for $K_{LO}=j \times n + m$, where $j=\dots-2, -1, 0, 1, 2,\dots$, where m is positive or negative. Among these, the most important ones are $3\omega_{LO} + 3\omega_{BB}$, $5\omega_{LO} + 5\omega_{BB}$, $7\omega_{LO} + 7\omega_{BB}$, $15\omega_{LO} - 3\omega_{BB}$, $13\omega_{LO} - 5\omega_{BB}$.

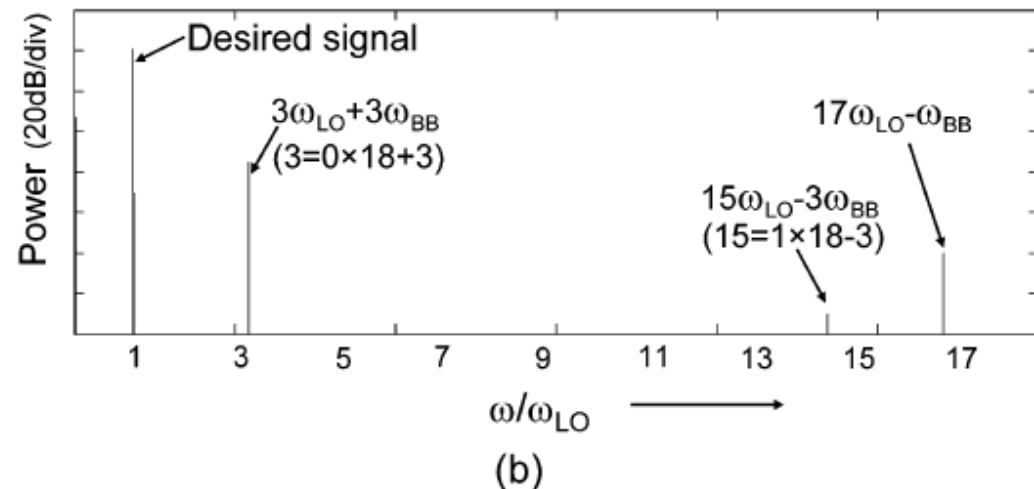
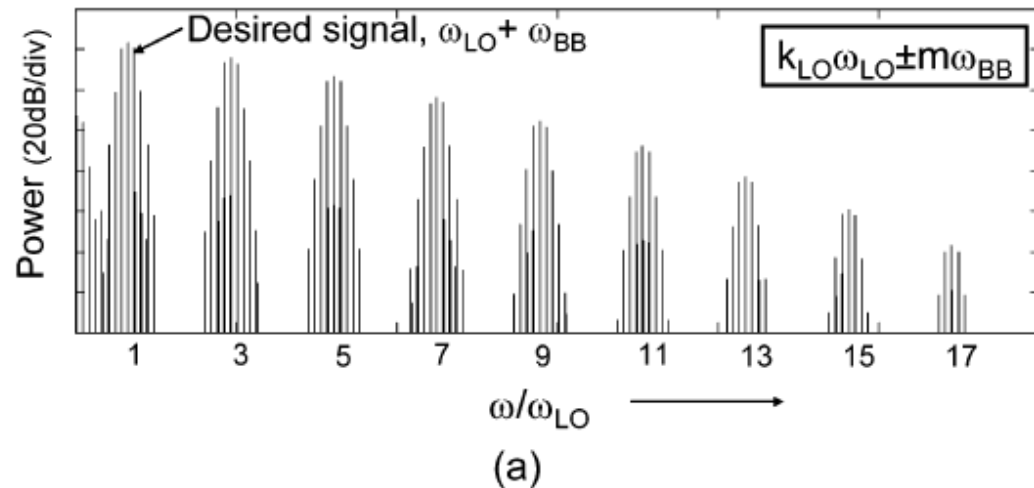

E. Mensink, E. A. M. Klumperink, and B. Nauta, "Distortion cancellation by polyphase multipath circuits," *IEEE Trans. Circuits Syst. I, Regular Papers*, vol. 52, no. 9, pp. 1785–1794, Sep. 2005.

Using 1/3 Duty Cycle

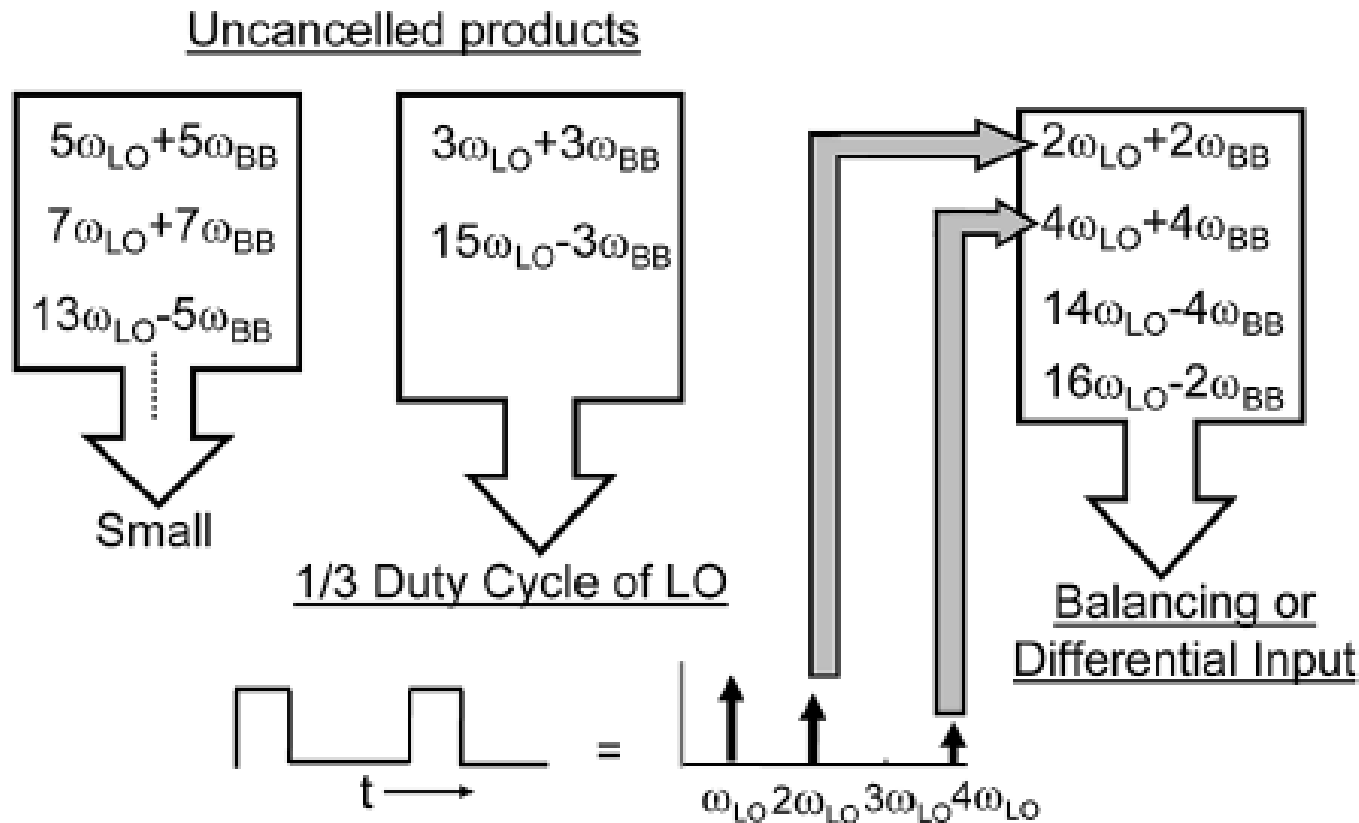

- First significant noncancelled product for an 18-path system with 1/3 duty cycle and balanced BB-signals is $17\omega_{LO} - \omega_{BB}$

Photo and output spectra of the 18-path Power Upconverter (PU) chip, with out-of-band power <math>< -40\text{ dBc}</math> up to the 17th harmonic (LO = 350 MHz)..

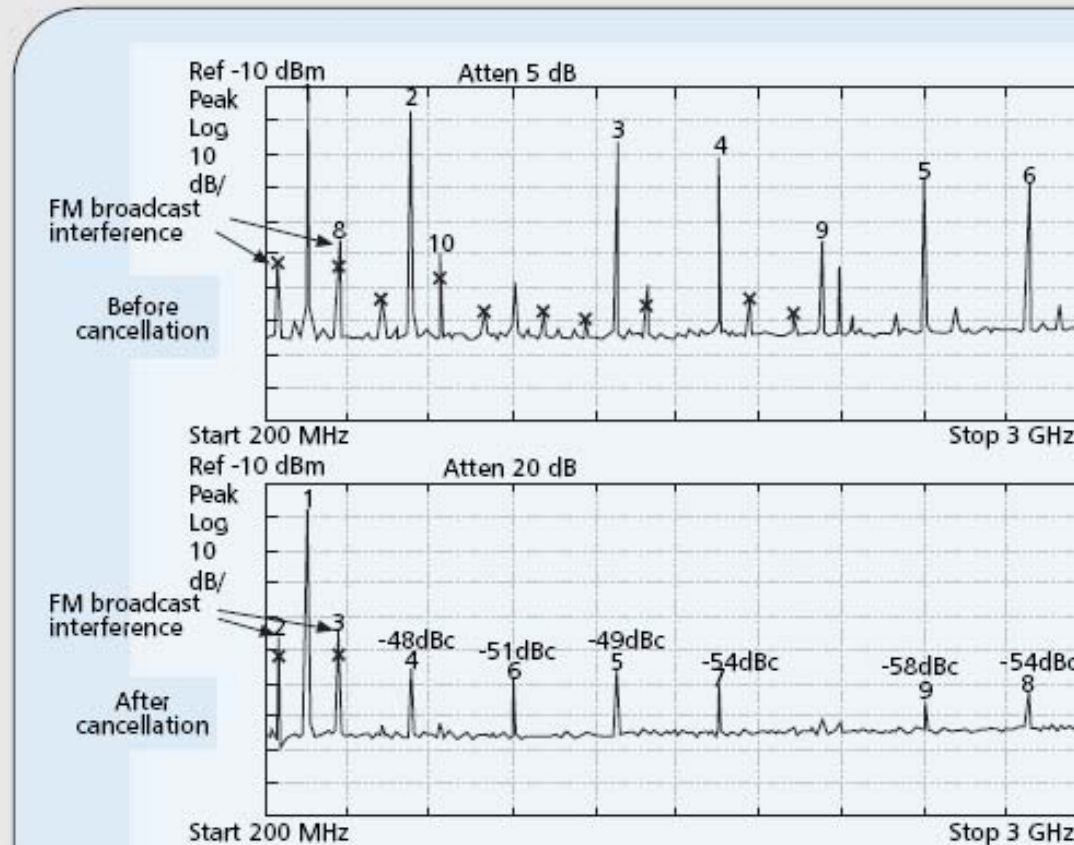
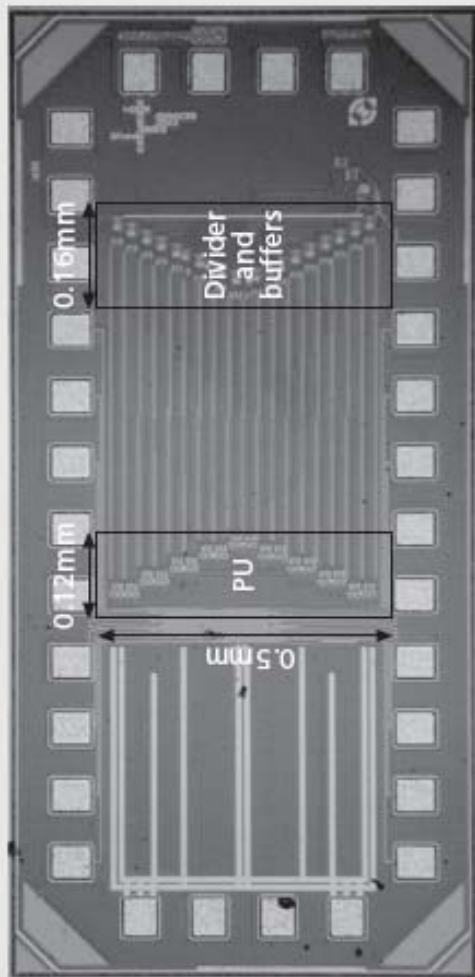

Extraction of Nonlinear Coefficients

Extraction of Nonlinear Coefficients

- A linearity test can be used but needs estimation of the output harmonics which requires costly analog and/or digital circuits.
- The analog approach involves down conversion of the harmonics followed by low pass filtering. A PLL is needed to generate the LOs. The design needs to be very wideband.
- The digital approach consists of down conversion followed by an ADC and digital DFT that can be designed to focus on the harmonic distortion.
- An alternative approach uses time average cross-correlation of the nonlinear system response to the sum of pseudo-random (PN-pseudo noise) sequences that are uncorrelated to each other with the product of the sequences.

Correlation Technique Extraction of Nonlinear Coefficients

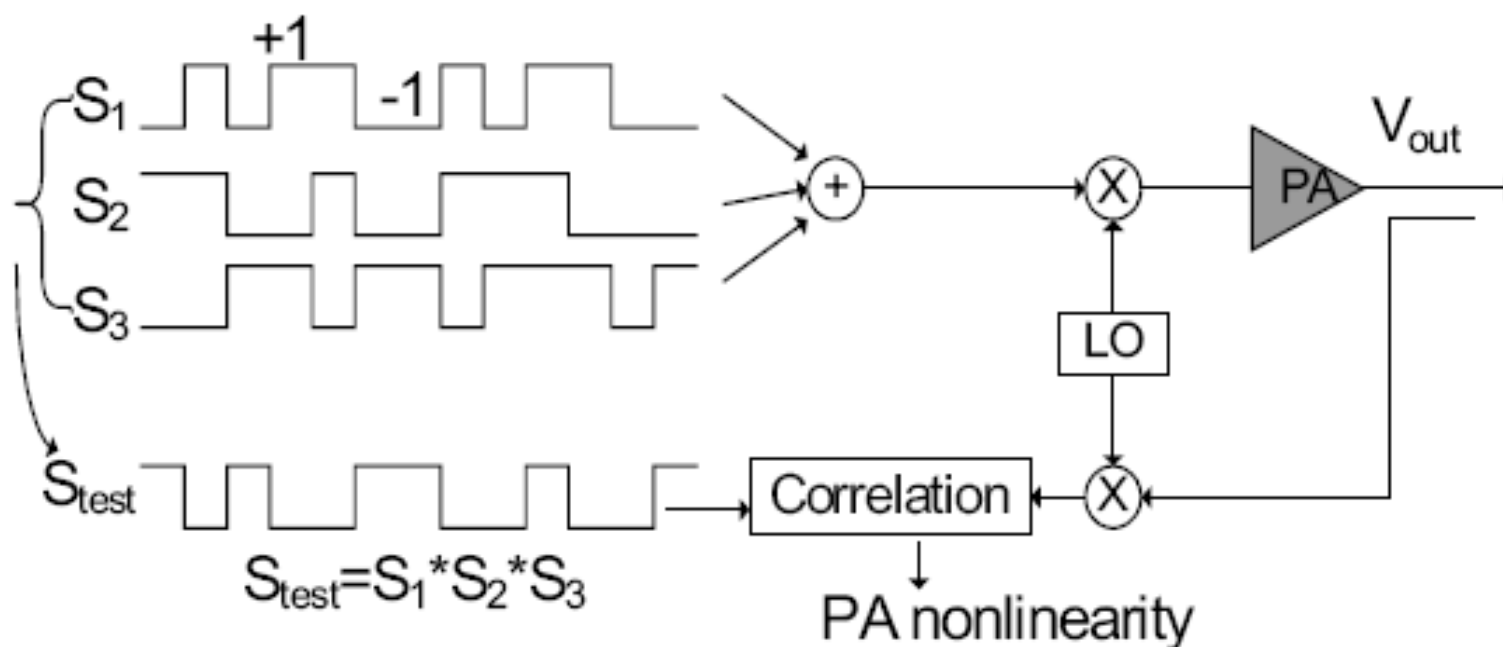

M. Y. Li, I. Galton, L. E. Larson and P. M. Asbeck, "Correlation Techniques for Estimation of Amplifier Nonlinearity," Radio and Wireless Conference, 2004 IEEE

Correlation Technique Extraction of Nonlinear Coefficients

$$V_{in}(t) = \sum (S_1(t) + S_2(t) + S_3(t))$$

$$V_{out}(t) = a_1 V_{in}(t) + a_3 V_{in}^3(t) + a_5 V_{in}^5(t)$$

$$\Phi_{V_{out}, S_{test}}(\tau) = \lim_{T \rightarrow \infty} \frac{1}{T} \int_0^T V_{out}(t) S_{test}(t + \tau) dt$$

$$S_{test} = S_1(t) S_2(t) S_3(t)$$

$$\Phi_{V_{out}, S_{test}}(\mathbf{0}) = \lim_{T \rightarrow \infty} \frac{1}{T} \int_0^T \bar{a}_3 S_{test}^2(t) + \textit{other terms} dt$$

The integral of the other terms will average out to zero. \bar{a}_3 depends on a_3 and a_5 .

M.Y. Li, I. Galton, L.E. Larson and P.M. Asbeck, "Nonlinear Estimation and Spectral Regrowth Prediction of Power Amplifiers using Correlation techniques"