

## Chapter IIIa

# The operational Amplifier and applications.

### III.1. Basic Model for the Operational Amplifier.

The OPERational AMPlifier (OPAMP) is a key building block in analog integrated circuit design. The OPAMP is composed by several transistors and passive elements (resistors and capacitors) and arranged such that its low frequency voltage gain is very high; the dc gain of the OPAMP-741 is around  $10^5$  V/V (10  $\mu$ V at the input give us 1 V at the output). The design of such complex circuit is discussed in chapter 6; here we will use a simplified linear macromodel to analyze the principles of OPAMP based circuits and their operation. Several circuits are studied such as basic amplifiers, first order and second order filters and some non-conventional applications. The versatility of the OPAMP will be evident at the end of this chapter.

To define the fundamental parameters of a system, let us consider a linear two-port system with two terminals grounded, as the one shown in Figure 3.1. There are 4 variables  $v_i$ ,  $i_i$ ,  $v_o$  and  $i_o$  to be studied. The interaction between the four variables can be defined in many different ways, depending on the definition of the dependent and independent variables; in real circuits these definitions depend on the input variable (current or voltage) and the most relevant output variable. Usually in voltage amplifiers the input signal is defined as  $v_i$  while the output is  $v_o$ .

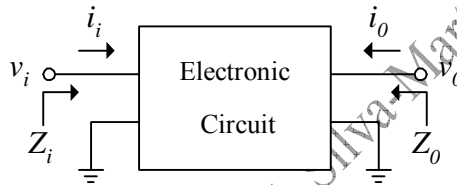

Fig. 3.1. Electronic circuit represented by a black box.

Since we are assuming that the circuit is linear, among other representations, we can describe the electronic circuit by using the following hybrid matrix representation:

$$\begin{bmatrix} i_i \\ v_o \end{bmatrix} = \begin{bmatrix} g_{11} & g_{12} \\ g_{21} & g_{22} \end{bmatrix} \begin{bmatrix} v_i \\ i_o \end{bmatrix} \quad \text{g-parameters} \quad (3.1a)$$

or

$$\begin{aligned} i_i &= g_{11}v_i + g_{12}i_o \\ v_o &= g_{21}v_i + g_{22}i_o \end{aligned} \quad (3.1b)$$

Notice that we are mixing currents and voltages in the matrix, then we call it hybrid representation of the circuit, and the resulting model is termed hybrid model. In many text books you can find at least 4 different set of parameters, but this is one of the most relevant ones for voltage amplifiers. Bipolar and MOS transistors models are based on another model called  $\pi$ -hybrid, to be discussed in the following chapters.

In equations 3.1b, the parameter  $g_{11}$  defines the input conductance, and it relates the input current and the input voltage needed by the circuit without considering the effect of the output current ( $i_o=0$ ); the circuit's input conductance is formally defined as follows:

$$g_{11} = \frac{1}{Z_i} = \left. \frac{i_i}{v_i} \right|_{i_o=0} \quad (3.2)$$

This parameter is measured by applying an input voltage source and measuring the input current; the output node is left open such that  $i_o=0$ . Since  $g_{11}$  is the ratio of the input current to the input voltage, while the output is left open, its units are amps/volts or  $1/\Omega$ .

The parameter  $g_{12}$  defines the reverse current gain of the topology, and it is defined as

$$g_{12} = \frac{i_i}{i_o} \Big|_{v_i=0} \quad (3.3)$$

This parameter represents the reverse current gain: current generated at the input due to the output current. In the ideal case this parameter is zero since usually the operational amplifiers are unidirectional; e.g. the input signal applied to the system generates an output signal, but the output signals (current or voltage) should not generate any signal at the input. For measuring this parameter it is required to short circuit the input port such that  $v_i=0$ , then apply a current at the output and measure the current generated at the input port. In practical circuits this parameter is very small and usually it is ignored.

The Forward voltage gain is defined as the ratio of the output voltage and input voltage without any load connected at the output.

$$g_{21} = A_V = \frac{v_o}{v_i} \Big|_{i_o=0} \quad (3.4)$$

This is certainly one of the most important parameters of the two-port system; **we also refer to  $A_V$  as the open-loop gain of the OPAMP**. It represents the circuit's voltage gain without any load impedance attached (output current equal zero).

Another important parameter is the system's output impedance, which relates the output voltage and the output current without taking the effects of the input signal. It is defined by

$$g_{22} = Z_0 = \frac{v_o}{i_o} \Big|_{v_i=0} \quad (3.5)$$

Thus, the two-port system can be represented by the four aforementioned parameters; the resulting macromodel is shown in Figure 3.2. For sake of clarification we are using impedances instead of admittances in this representation. Notice that a current controlled current source (ICCS) is used for the emulation of parameter  $g_{12}$  since it represents the input current (input port) being generated by the output current (output port). A resistor can not represent this parameter since current is flowing in one port but the voltage at the other port controls it. Similar comments apply to the voltage controlled voltage source represented by  $A_V v_i$  ( $g_{21} v_i$ ).

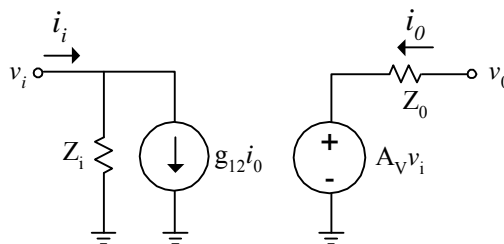

Fig. 3.2. Linear macromodel of a typical voltage amplifier using hybrid parameters.

**Model for the OPAMP.** The ideal OPAMP is a device that can be modeled by using the circuit of Fig. 3.2 with  $A_V=\infty$ ,  $g_{12}=0$ ,  $Z_i=\infty$ , and  $Z_o=0$ . This is of course an unrealistic model, but it is enough for understanding the basic circuits and their operation. We will see that when you connect several circuits in cascade for complex signal

processing, both input and output impedances are important parameters that affect the overall performance of the system. In this section, however these effects are not considered.

**Discuss here the main limitations such as input impedance, limited DC gain and DC offsets and input bias current.**

### III.2. Basic configurations: Inverting and non-inverting amplifier.

**Inverting configuration.** The first topology to be studied is the inverting amplifier shown in fig. 3.3a. It consists of an impedance connected between the input source and the OPAMP's inverting terminal; the second impedance is connected from the inverting terminal to the output of the OPAMP.  $Z_2$  provides a negative feedback (connecting the OPAMP's output and the negative input); this is the main reason for the excellent properties of this configuration. The simplified linear macromodel of the OPAMP is used for the representation of the inverting amplifier, and the equivalent circuit shown in fig. 3.3b. By using basic circuit analysis techniques it can be easily find that

$$\frac{v_i - v_x}{Z_1} + \frac{v_o - v_x}{Z_2} = 0 \quad (3.5)$$

and

$$v_o = -A_v v_x \quad (3.6)$$

Solving these equations as function of the input and output voltages yields:

$$\frac{v_o}{v_i} = - \left( \frac{1}{1 + \frac{Z_2/Z_1}{A_v}} \right) \left( \frac{Z_2}{Z_1} \right) \quad (3.7)$$

This relationship is also known as closed-loop amplifier's gain since the feedback resistor in combination with the OPAMP form a closed loop. If the open-loop gain of the OPAMP  $A_v$  is very large, then the first factor can be approximated as unity and the closed-loop voltage gain becomes

$$\frac{v_o}{v_i} = - \frac{Z_2}{Z_1} \quad (3.8)$$

This result shows that **if negative feedback is used and if the open-loop gain of the OPAMP is large enough, the overall amplifier's voltage gain depends on the ratio of the two impedances.** Unlike to the gain of the open-loop gain of the OPAMP that can vary by more than 50 % due to transistor's parameters variations and temperature gradients, as will be explained in the following sections, the closed loop gain is quite accurate, especially if same type of impedances are used. Usually ratio of impedances is more precise than the absolute value of components; e.g. ratio of capacitors fabricated in CMOS technologies can be as precise as 99.5 % while the absolute value of the capacitance may change by more than 20%.

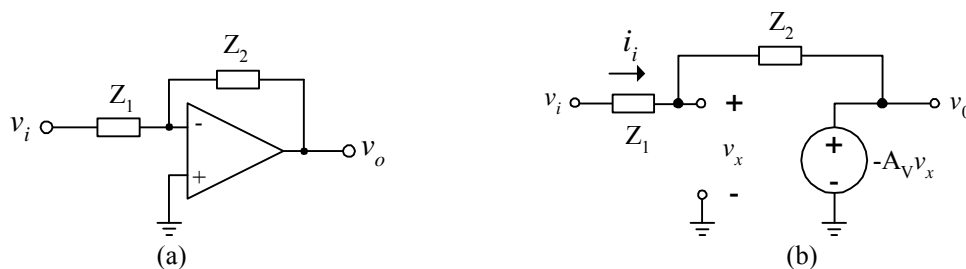

Fig. 3.3. Inverting amplifier: a) the circuit and b) the linear macromodel assuming that OPAMP input is infinity and output impedance is zero.

Another important observation is that the differential voltage at the OPAMP input  $v_x$  (see Fig. 3b) is ideally zero. The reasoning behind this observation is as follows: according to 3.8, the output voltage is bounded (not infinity) if  $Z_1$  is not zero or  $Z_2$  is not infinite, hence  $v_i$  is also bounded. Under these conditions and according to expression 3.6 the OPAMP input voltage  $v_x$  is very small if  $A_v$  is large enough; the larger the OPAMP open loop gain the smaller signal at the input of the OPAMP. Therefore the **inputs of the OPAMP can be considered as a virtual short; the voltage difference between the two input terminals ( $v_+$  -  $v_-$ ) is very small but they are not physically connected.** The virtual short principle is extremely useful in practice; most of the transfer functions can be easily obtained if this property is used. To illustrate its use, let us consider again the circuit of fig. 3.3b. Due to the virtual ground at the input of the OPAMP,  $v_x=0$  (virtual short) and the input current  $i_i$  is determined by  $v_i/Z_1$ . Since the input impedance of the OPAMP is infinite,  $i_i$  flows throughout  $Z_2$ , leading to an output voltage given by  $-i_i Z_2$ . As a result, the closed-loop voltage gain becomes equal to  $-Z_2/Z_1$ , as stated in equation 3.8.

If the impedances  $Z_1$  and  $Z_2$  are replaced by resistors as shown in Fig. 3.4a, we end up with the basic resistive inverting amplifier. The closed-loop gain is then obtained as

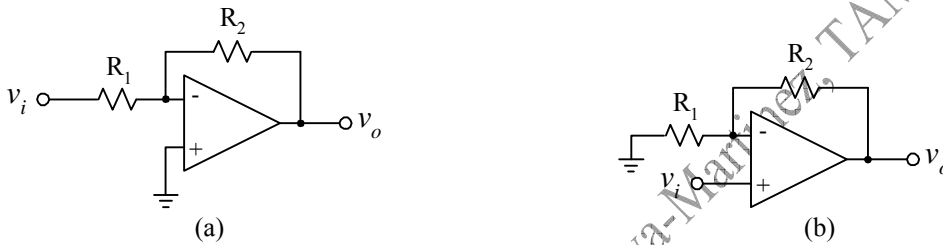

Fig. 3.4. Resistive amplifiers: a) inverting configuration and b) non-inverting configuration.

$$\frac{v_o}{v_i} = -\frac{R_2}{R_1} \quad (3.9)$$

Notice that in the case of the inverting configuration, the amplifier's input impedance is determined by  $R_1$ ; this is a result of the virtual ground present at the inverting terminal of the OPAMP. Hence, if several inverting amplifiers are connected in cascade we have to be aware that the amplifier must be able to drive the input impedance of the next stage.

**Non-inverting voltage gain configuration.** If the input signal is applied at the non-inverting terminal and  $R_1$  is grounded, as shown in fig. 3.4b, the non-inverting configuration is obtained. Notice that the **feedback is still negative. If  $R_2$  is connected to the positive terminal, the circuit becomes unstable** and useless for linear applications; this will be evident in the following sections. The closed-loop voltage gain of the non-inverting configuration can be easily obtained if the virtual short principle is used. Due to the high gain of the OPAMP, the voltage difference between the inverting and non-inverting terminals is very small; hence **the voltage at the non-inverting terminal of the OPAMP is also  $v_i$ .** The current flowing through  $R_1$  and  $R_2$  is then given by  $v_i/R_1$ ; therefore the output voltage is computed as

$$\frac{v_o}{v_i} = \frac{v_i + i_1 R_2}{v_i} = \frac{v_i + (v_i/R_1)R_2}{v_i} = 1 + \frac{R_2}{R_1} \quad (3.10)$$

The voltage gain is therefore greater or equal than 1. An important characteristic of this configuration is that ideally its input impedance is infinity; hence several stages can be easily connected in cascade. A special case of the non-inverting configuration is the buffer configuration shown in figure 3.5. If  $R_1=\infty$ , according to equation 3.10, the voltage gain is unity; in this case the value of  $R_2$  is not critical and can even be short-circuited ( $R_2=0$ ). This topology is also known as unity gain amplifier or buffer, and it is very popular for driving small impedances; e.g. speakers, motors, etc.

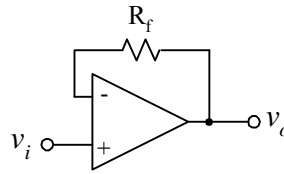

Fig. 3.5 OPAMP in unity gain buffer configuration

Emphasis on loading effects; discuss these issues in class!

### III.3. Amplifier with multiple inputs and superposition.

Input signals can be applied to the two inputs of the OPAMP, as shown in Fig. 3.6.  $R_1$  and  $R_2$  are a voltage divider; the input voltage at the non-inverting ( $v_+$ ) terminal is then

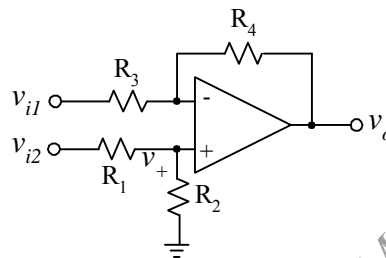

Fig. 3.6. Amplifier configuration with two input signals applied to the non-inverting and inverting terminals.

$$\frac{v_+}{v_{i2}} = \frac{R_2}{R_1 + R_2} \quad (3.11)$$

If a virtual short at the OPAMP inputs is assumed, the voltage at the inverting and non-inverting terminals is the same, and determined by  $v_+$ . Using KCL at the inverting terminal of the circuit leads to

$$\frac{v_o - v_+}{R_4} = \frac{v_+ - v_{i1}}{R_3} \quad (3.12)$$

Using equations 3.11 and 3.12, the output voltage is obtained, yielding

$$v_o = -\left(\frac{R_4}{R_3}\right)v_{i1} + \left(\frac{R_2}{R_1 + R_2}\right)\left(1 + \frac{R_4}{R_3}\right)v_{i2} \quad (3.13)$$

Notice that the output voltage is a linear combination of the two input signals: the first component is determined by the  $v_{i1}$  and the other one determined by  $v_{i2}$ . This analysis can always be used, but we can also take advantage of the properties of linear systems.

**Superposition principle for a linear system.** *If the OPAMP is considered as a linear device and only linear impedances are used, then the output voltage is a linear combination of all the inputs applied.* If several inputs are applied to the linear circuit, then the output can be obtained considering each input signal at a time; e.g. grounding all other input signals and applying the input signal under study. **Therefore, the following property holds:** if

$$v_o(v_{i1}, v_{i2}, \dots, v_{iN}) = \sum_{j=1}^N \left( k_j v_{ij} \Big|_{v_{ik} \text{ } k \neq j = 0} \right) \tag{3.14a}$$

then

$$v_o(v_{i1}, v_{i2}, \dots, v_{iN}) = v_o(v_{i1}, 0, \dots, 0) + v_o(0, v_{i2}, \dots, 0) + \dots + v_o(0, 0, \dots, v_{iN}) \tag{3.14b}$$

This property is known as the *superposition principle*. Let us apply this principle to the topology shown in Fig. 3.6, where two inputs are applied to the amplifier. The circuit is analyzed by applying one input signal at a time: if  $v_{i1}$  is considered,  $v_{i2}$  is made equal zero. The equivalent circuit is shown in Fig. 3.7a.

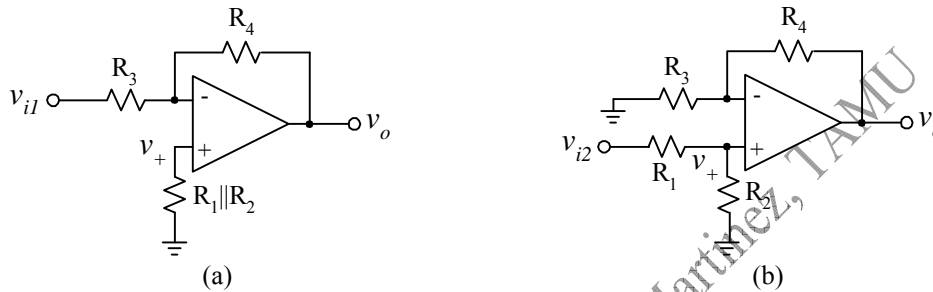

Fig. 3.7 Equivalent circuits for the computation of the output voltage: a) for  $v_{i1}$  and b) for  $v_{i2}$ .

Since the input impedance of the OPAMP is infinite, the current flowing through  $R_1 \parallel R_2$  is zero, and  $v_+ = 0$ . The resulting circuit is the typical inverting amplifier where the output voltage is given by  $-(R_4/R_3)v_{i1}$ ; notice that this output corresponds to the first term in equation 3.13. If the first input is grounded and signal  $v_{i2}$  is considered, the resulting equivalent circuit is depicted in fig. 3.7b. The voltage at the non-inverting terminal is given by equation 3.11, and the output voltage is equal to  $v_o = (1 + R_4/R_3)v_+$ ; the final result leads to the second term of equation 3.13.

**Generalization of basic configurations.** The concepts of infinite input impedance, zero output impedance, virtual short of the OPAMP inputs and linear superposition are especially useful when complex circuits are designed. An analog inverting adder is shown in fig. 3.8a; the output voltage can be easily found if we apply the superposition principle to each input. The equivalent circuit for the  $j$ th-input is depicted in fig. 3.8b. Since only  $R_j$  is connected to  $v_{ij}$ , the resistors connected to the other inputs must be grounded. These resistors are connected between the physical ground and the virtual ground generated by the negative feedback and the large open-loop voltage gain of the OPAMP, as a result of this the current flowing through all grounded resistors is zero, then  $i_j$ , generated by  $v_{ij}$ ,  $R_j$  and the virtual ground node  $v_x (=0)$  flows throughout  $R_f$ . The output voltage is then obtained as  $-(R_f/R_j)v_{ij}$ . By using the same concept to all inputs, the amplifier's output voltage is found as

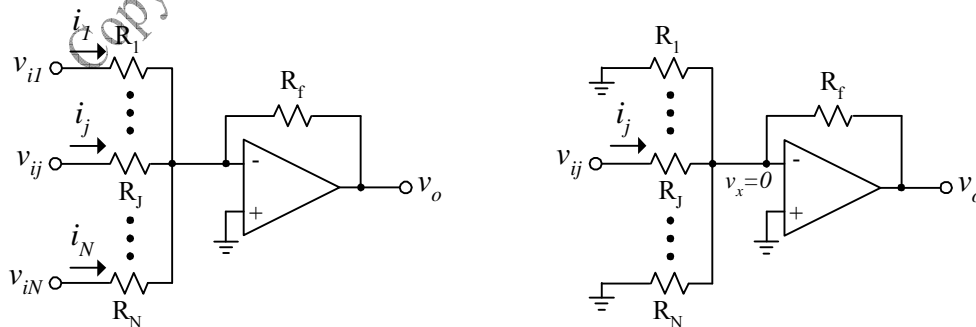

Fig. 3.8. a) Analog adder and b) equivalent circuit for analyzing the output voltage due to  $v_{ij}$ .

$$v_o = -\sum_{j=1}^N \left( \frac{R_f}{R_j} \right) v_{ij} \quad (3.15)$$

An interesting advantage of this circuit is that each one of the input resistors independently controls the voltage gain for each input. This is an important circuit property used for the design of analog-digital converters for instance where the addition of binary weighted signals are required.

An analog non-inverting adder is depicted in fig. 3.9a. Similarly to the previous case, the output voltage can be computed by using superposition. Shown in fig. 3.9b is the equivalent circuit for the  $j$ th-input signal, and making all other inputs equal zero. The voltage at the non-inverting terminal is the result of the voltage divider determined by the resistors lumped to node  $v_{+j}$  as follows:

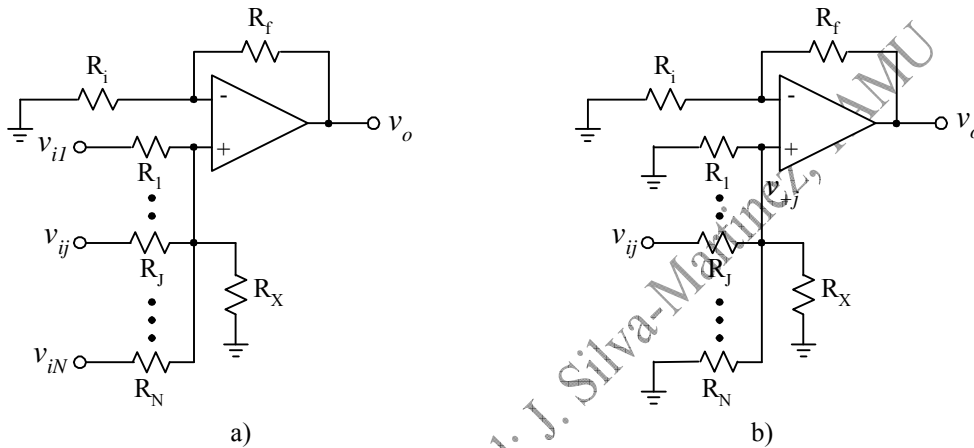

Fig. 3.9. a) Non-inverting amplifier with multiple inputs and b) equivalent circuit for the  $j$ th input.

$$\frac{v_{+j}}{v_{ij}} = \frac{R_1 \parallel R_2 \cdots R_{j-1} \parallel R_{j+1} \cdots \parallel R_N \parallel R_X}{(R_1 \parallel R_2 \cdots R_{j-1} \parallel R_{j+1} \cdots \parallel R_N \parallel R_X) + R_j} \quad (3.16)$$

Since many components are in parallel for the analysis of this type of networks it is very often more convenient to use admittances instead of impedances. For this example, the previous equation can also be expressed as

$$\frac{v_{+j}}{v_{ij}} = \frac{\frac{1}{R_j}}{\frac{1}{R_j} + \frac{1}{R_1 \parallel R_2 \cdots R_{j-1} \parallel R_{j+1} \cdots \parallel R_N \parallel R_X}} \quad (3.16b)$$

The numerator ( $1/R_j$ ) is identified as the admittance of the element connected between the input signal and  $v_{+j}$ . The denominator represents the parallel of all elements attached to  $v_{+j}$ . The **parallel connection of impedances is also equivalent to the reciprocal of the addition of their admittances**; then 3.16 can be expressed by the following equivalent expression

$$\frac{v_{+j}}{v_{ij}} = \frac{g_j}{\sum_{i=1}^N (g_i) + g_X} \quad (3.17)$$

where  $g_i = 1/R_i$ . Once  $v_{+j}$  is obtained, the output voltage generated by  $v_{ij}$  can be obtained. Since  $v_{+j}$  is the voltage at the non-inverting terminal, to find the output voltage for this input is straightforward as  $v_{oj} = (1 + R_f/R_i)v_{+j}$ . Taking into account all the input signals and applying the superposition principle, it can be shown that the overall output voltage is a linear combination of all inputs; the result of this analysis yields,

$$v_o = \left(1 + \frac{R_f}{R_i}\right) \left(\sum_{j=1}^N v_{+j}\right) = \left(1 + \frac{R_f}{R_i}\right) \left(\sum_{j=1}^N \left(\frac{g_j v_{ij}}{\sum_{i=1}^N (g_i) + g_X}\right)\right) = \left(\frac{1 + \frac{R_f}{R_i}}{\sum_{i=1}^N (g_i) + g_X}\right) \left(\sum_{j=1}^N g_j v_{ij}\right) \quad (3.18)$$

Each input signal has a contribution to the output voltage that depends of all resistors, unlike the case of the inverting topology. The input impedance for each input depends on the array of resistors; for instance the input impedance seen by the  $j$ th-input signal is

$$Z_j = R_j + (R_1 \parallel R_2 \cdots R_{j-1} \parallel R_{j+1} \cdots \parallel R_N \parallel R_X) \quad (3.19)$$

Similar expressions can be obtained for all other input sources.

**Example:** Design a circuit that implements the following equation:

$$v_o(t) = 10v_1 + 20v_2 + 5$$

If needed use the supply voltages  $\pm 15$  V. The circuit shown below can be used; this is not the only solution, combinations of inverting and non-inverting circuits might be used as well. The design process consists of finding the resistance values. For that purpose, the following equations must be solved:

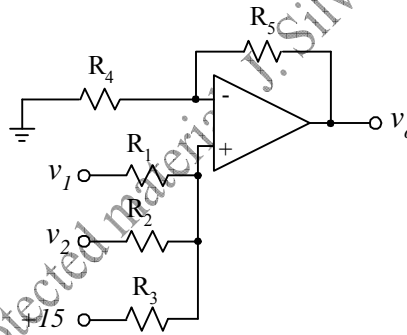

$$10 = \left(1 + \frac{R_5}{R_4}\right) \left(\frac{g_1}{g_1 + g_2 + g_3}\right)$$

$$20 = \left(1 + \frac{R_5}{R_4}\right) \left(\frac{g_2}{g_1 + g_2 + g_3}\right)$$

$$5 = \left(1 + \frac{R_5}{R_4}\right) \left(\frac{g_3}{g_1 + g_2 + g_3}\right)$$

Solve this set of equations, and find the numerical values; it is evident that  $g_1 = 2g_3$  and that  $g_2 = 4g_3$ .

#### III.4. Amplifiers with very large gain/attenuation factors.

Very large gain amplifiers require large spread of the components. In analog integrated circuits design, it is difficult to control properly such large ratios, and very often they are very demanding of silicon area. Some configurations allow us to reduce this spread.

**Large gain inverting amplifier using resistors in a T-array.** Large voltage gain factors require very large resistors; the array of resistors shown in figure 3.10 can be used to “increase” the effective feedback resistor. The circuit’s transfer function can obviously be obtained by using conventional circuit analysis techniques such as KCL. It is however to useful to analyze the circuit based on the following observations:



1. Since the inverting terminal is at the ground potential due to the virtual short at the OPAMP input, the resistor  $R_2$  is connected between node  $v_x$  and (virtual) ground; then it is in parallel with  $R_3$  if you analyze the circuit from the output. Therefore, the voltage  $v_x$  can be computed as

$$v_x = \left( \frac{R_2 \parallel R_3}{R_2 \parallel R_3 + R_4} \right) v_0 \quad (3.20)$$

Notice that  $v_x$  is an attenuated version of the output voltage.

2. Also, as a result of the virtual ground at the OPAMP's input, the current flowing through  $R_2$  is given by  $v_x/R_2$ . If the OPAMP is ideal, the current flowing through  $R_1$  is equal to the one flowing through  $R_2$ , and then the output voltage can be computed from the following expression:

$$\frac{v_i}{R_1} = -\frac{v_x}{R_2} = -\left( \frac{R_2 \parallel R_3}{R_2 \parallel R_3 + R_4} \right) \left( \frac{v_0}{R_2} \right) \quad (3.21)$$

Therefore, the voltage gain is

$$\frac{v_0}{v_i} = -\left( \frac{(R_2 \parallel R_3) + R_4}{R_2 \parallel R_3} \right) \left( \frac{R_2}{R_1} \right) \quad (3.22)$$

The voltage gain is therefore equivalent to the gain of a two-stage amplifier; larger gain factors are obtained with reduced resistive spread.

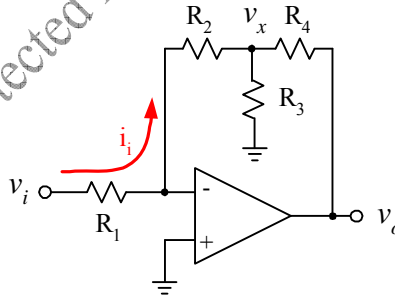

Fig. 3.10. Resistive voltage amplifier for high-gain applications.

If further reduction on the resistive spread is needed, two T-networks can be used as shown in Fig. 3.11. Similarly to the previous case, the voltage  $v_x$  is equal to  $-(R_2/R_1)v_i$ ; notice that  $v_x$  is an attenuated version of  $v_y$  and this last voltage is an attenuated version of  $v_o$ . These voltages are related by the following expressions:

$$\frac{v_x}{v_y} = \frac{(R_2 \parallel R_3)}{(R_2 \parallel R_3) + R_4} \quad (3.23)$$

$$\frac{v_y}{v_0} = \frac{\left( (R_2 \parallel R_3) + R_4 \right) \parallel R_5}{\left[ \left( (R_2 \parallel R_3) + R_4 \right) \parallel R_5 \right] + R_6} \quad (3.24)$$

Then the closed loop voltage gain is obtained as

$$\frac{v_o}{v_i} = - \left( \frac{v_o}{v_y} \right) \left( \frac{v_y}{v_x} \right) \left( \frac{v_x}{v_{in}} \right) = - \left( \frac{\left[ \left( (R_2 \parallel R_3) + R_4 \right) \parallel R_5 \right] + R_6}{\left( (R_2 \parallel R_3) + R_4 \right) \parallel R_5} \right) \left( \frac{\left( (R_2 \parallel R_3) + R_4 \right)}{\left( R_2 \parallel R_3 \right)} \right) \left( \frac{R_2}{R_1} \right) \quad (3.25)$$

This voltage gain can be very large; it is in fact determined by multiplication of 3 terms, which is equivalent to a 3-stage amplifier. Notice that the input impedance of the non-inverting circuit is determined by  $R_1$ .

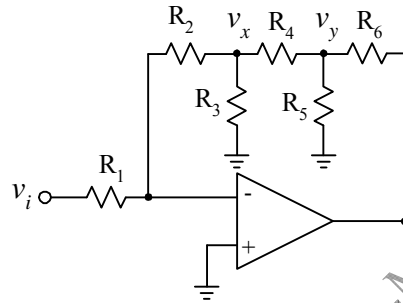

Fig. 3.11. Resistive amplifier using a T-configuration for large gain factors

**Very large attenuation factors.** The T-network can also be used for the design of large attenuation factors, for instance in applications related to power amplifiers where the input signal might be in the range of 100 V or more but the OPAMP can handle only 12 V or less. The resulting circuit using a T-network at the input is shown in figure 3.12. The voltage  $v_x$  is an attenuated version of the incoming signal, and the voltage gain is adjusted to the proper level by the typical inverting configuration ( $R_3$  and  $R_4$ ). The attenuating factor, considering again a virtual ground at the input, is determined by  $R_1$  and the parallel of  $R_2$  and  $R_3$ ; the voltage gain between  $v_x$  and  $v_o$  is determined by the ratio of resistors  $R_4$  and  $R_3$ . Therefore, the output voltage is given by:

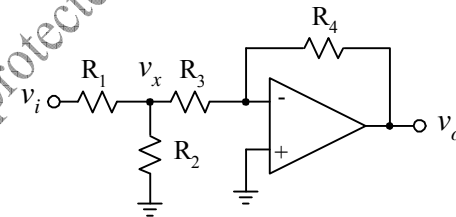

Fig. 3.12. Resistive amplifier using a T-configuration for large attenuation factors

$$\frac{v_o}{v_i} = \left( \frac{v_o}{v_x} \right) \left( \frac{v_x}{v_i} \right) = \left( - \frac{R_4}{R_3} \right) \left( \frac{R_2 \parallel R_3}{R_1 + (R_2 \parallel R_3)} \right) \quad (3.26)$$

The first factor is the result of the voltage divider at the input of the structure, while the second factor is the result of the non-inverting amplification of  $v_x$ . You can also use the double T-cell structure; it is left to the student to find out the voltage gain in that case; **DO IT, this can be a midterm question.**

### III.5. RC Circuits: Integrators and differentiators.

**Basic integrators.** If the feedback resistor is replaced by a capacitor, we obtain a lossless integrator; the circuit is shown below. In this circuit, the input voltage  $v_i$  is converted into a current by  $R_1$  and the virtual ground present at the input of the OPAMP, similarly to the case of the resistive amplifier. The resulting current is injected into the feedback capacitor  $C_2$  where it is integrated; the resulting output voltage is the integral of the injected current. The

analysis of this circuit can easily be done in the frequency domain where the characteristic impedance of the capacitor is given by  $1/(j\omega C_2)$ . The transfer function of the inverting configuration is, as in the previous cases, determined by the ratio of the impedance in feedback and the input impedance, leading to the following result:

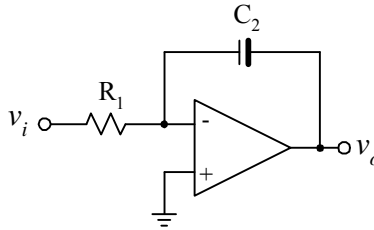

Fig. 3.13. Lossless inverting Integrator

$$H(s) = \frac{v_o}{v_i} = -\frac{1}{sR_2C_1} \quad (3.27)$$

where  $s=j\omega$ . This circuit has a pole at the origin and a “phantom” zero at  $\omega=\infty$  (why?). The magnitude response is extremely large at low frequencies, and decreases at higher frequency with a rolloff of  $-20$  dB/decade. The phase response is  $+90$  ( $-270$ ) degrees and independent of the frequency. Notice that at  $\omega=1/R_2C_1$ , the magnitude of the voltage gain is unity. Usually this circuit is not used as a standalone device, but is the key building block for high-order filters and analog-digital converters.

The combination of resistors and capacitors lead to the generation of poles and zeros; for example, the circuit implementation of a first order filter is shown in figure 3.14. This circuit is also known as a lossy integrator because while  $R_1$  injects charge into  $C_2$ , the resistor  $R_3$  leaks (introduces losses) the charge stored in the capacitor. The gain of this circuit is also determined by the ratio of the equivalent impedance in feedback and the input impedance. In this circuit, the equivalent feedback impedance is composed by the parallel of the impedance of the capacitor ( $1/j\omega C_2$ ) and  $R_3$ . The low frequency gain, where the impedance of the capacitor can be ignored, is determined by the ratio of the two resistors; it is evident that the voltage gain is given by  $-R_3/R_1$ . At very high frequencies, the impedance of  $C_2$  dominates the feedback and the circuit behaves as the lossless integrator shown in figure 3.19 (gain defined by  $-1/sR_1C_2$ ). The overall voltage gain is given by:

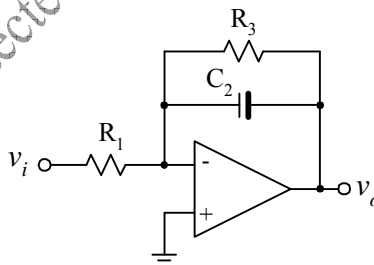

Fig. 3.14. First order lowpass filter

$$H(s) = -\frac{R_3}{R_1} \frac{1}{1 + sR_3C_2} \quad (3.28)$$

The low-frequency gain is, as expected, determined by the ratio of the resistors. The pole is located at  $\omega=1/R_3C_2$ , and for frequencies beyond this frequency the voltage gain decreases with a rolloff of  $-20$  dB/decade.

The main differences between this circuit and the passive lowpass filter (voltage divider) are twofold: a) in the active realization (with OPAMP) the low frequency gain can be greater than 1 by adjusting the ratio of the resistors while in the passive filter the gain is always less than 1; b) the OPAMP allows us to connect the circuit to the next

stage without affecting the transfer function; this is due to the small output impedance of the OPAMP. A typical transfer function obtained with this circuit is depicted in the following plot;

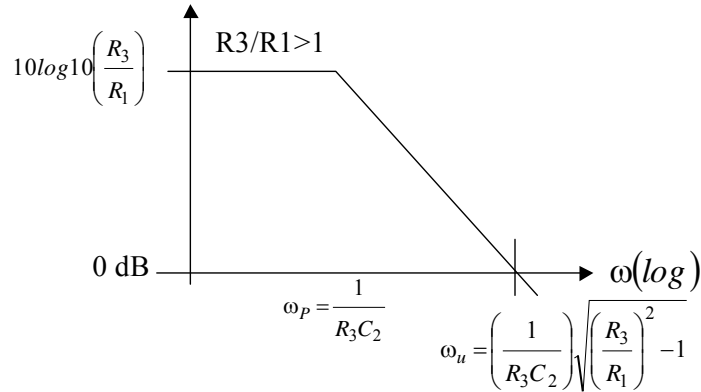

Fig. 3.15. Magnitude response for a first order filter.

The unity gain frequency is another important parameter; it can be obtained by taking the magnitude (or square magnitude) of equation 3.28, and equating it to 1. The resulting equation can be solved for the frequency, leading to the following result (find it yourself)

$$\omega_u = \left( \frac{1}{R_2 C_1} \right) \sqrt{\left( \frac{R_2}{R_1} \right)^2 - 1} \tag{3.29}$$

For  $R_2 \gg R_1$ , this frequency is approximately given by  $\omega_u \approx 1/R_1 C_1$ . Notice that for  $R_2 < R_1$  the solution is imaginary, meaning that the unity gain frequency does not exist; in fact you can not find any frequency where the gain is unity for an attenuator (dc gain less than 1). For  $R_2 < R_1$ , the low frequency gain is less than 1; hence the transfer function does not have any intersection with the 0 dB curve.

The general first order transfer function can be implemented by using the topology shown in fig. 3.16. Since the elements are in parallel, it is very convenient to find the voltage gain as the ratio of the equivalent input admittance and the equivalent feedback admittance as follows:

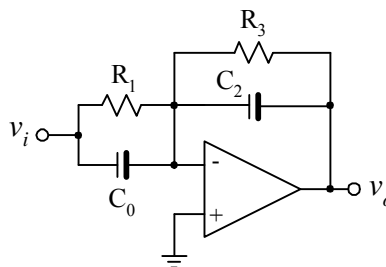

Fig. 3.16. General first order filter

$$H(s) = -\frac{g_1 + sC_0}{g_3 + sC_2} = -\left( \frac{R_3}{R_1} \right) \left( \frac{1 + sR_1 C_0}{1 + sR_3 C_2} \right) \tag{3.30}$$

With this circuit, you can design the following filters:

- (a) Lowpass filters if  $C_0$  is removed. The pole's frequency is given by  $1/R_3 C_2$
- (b) Amplifier if  $C_0$  and  $C_2$  are removed. Gain =  $-R_3/R_1$
- (c) Amplifier if the resistors are removed. Gain =  $-C_0/C_2$  (not very practical, especially for low frequency applications)

(d) High-pass if  $R_1$  is removed. Pole's frequency at  $1/R_3C_2$ , and high frequency gain =  $-C_0/C_2$ .

The high-pass transfer function can also be realized if a series of a capacitor and resistor is used, as shown in the figure below. Low frequency components are blocked by the capacitor due to its high impedance at low frequencies. At high frequencies the capacitor behaves as a short circuit, and the gain is given by the ratio of the resistors. Using typical circuit analysis techniques, the overall transfer function can be obtained as

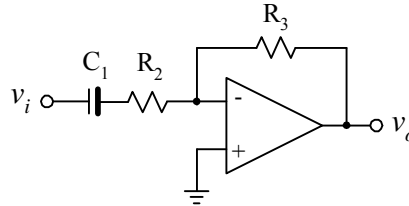

Fig. 3.17. First order High-pass filter using a series capacitor.

$$H(s) = -\frac{R_3}{R_2 + \frac{1}{sC_1}} = -\left(\frac{R_3}{R_2}\right) \left(\frac{sR_3C_1}{1 + sR_2C_1}\right) \quad (3.31)$$

A DC zero and a pole located at  $\omega = 1/R_2C_1$  can be observed. After the pole's frequency the voltage gain is mainly determined by the ratio of the resistors  $-R_3/R_2$ .

**Non-inverting integrator.** A non-inverting amplifier is implemented by using the following circuit. It is usually an expensive implementation, since the topology requires matched elements. The transfer function can be easily obtained by noting that the voltage at the non-inverting terminal is the result of a voltage divider between  $R$  and  $C$  ( $v_+/v_{in} = 1/(1+sRC)$ ). The voltage at the non-inverting terminal is then amplified by a factor  $1$  plus the ratio of the feedback impedance  $1/sC'$  and the resistor  $R'$ . The resulting transfer function yields;

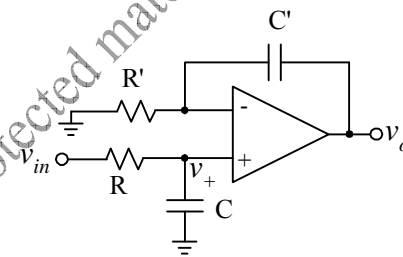

Fig. 3.18. Non-inverting lossless integrator

$$H(s) = \left(\frac{1}{sR'C'}\right) \left(\frac{1 + sR'C'}{1 + sRC}\right) \quad (3.32)$$

That corresponds to a non-inverting integrator if  $R'C' = RC$ ; in this case, the voltage gain decreases when the frequency increases with a rolloff of  $-20$  dB/decade and its phase is  $-90$  degrees. The phase at DC is  $+90$  degrees.

### III.6. Instrumentation amplifiers.

In many practical applications, it is desirable to use amplifiers with very large input impedance and very low output impedance. This is the case when the sensors have large output impedance and or limited current driving capabilities. For those applications, the inverting amplifier based on two resistors can not be used since its input impedance is finite; e.g. defined by the input resistance. The only option is to use non-inverting amplifiers, as the ones shown in figure 3.19. In case the incoming signal is differential carried out by  $v_{i1}$  and  $v_{i2}$ , therefore two non-

inverting amplifiers are used. In a differential system, the information is determined by the voltage difference between the two inputs rather than by the voltage at each node.

The circuit shown in figure 3.19a is composed by 2 single-ended non-inverting amplifiers. The circuit is a particular case of the circuit shown in Fig. 7b;  $R1=0$ ,  $R2=\infty$ ,  $R3=\infty$ ,  $R4=0$  that leads to a unity-gain amplifier (buffer) with very large input impedance. Since the OPAMP output impedance is very small you can easily connect inverting amplifiers after this structure if required. The benefits of these buffers will be evident in the following chapters.

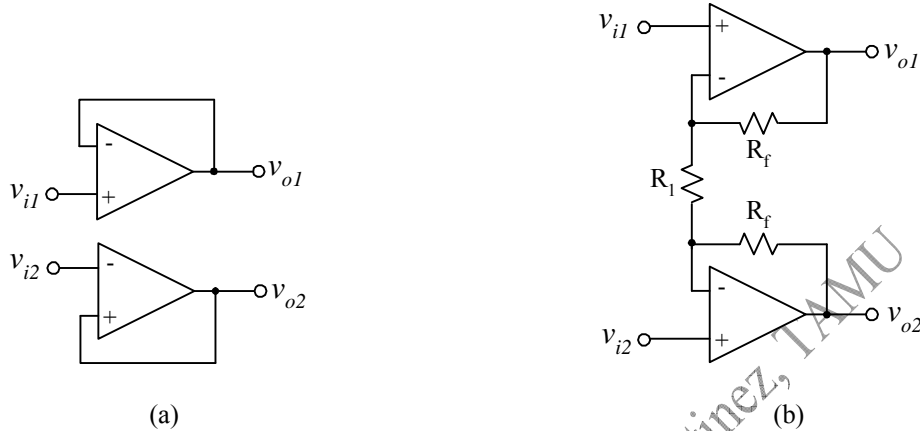

Fig. 3.19. Fully-differential amplifiers based on: buffers and b) non-inverting amplifiers.

The topology shown in figure 3.19b is more useful and can provide voltage amplification greater than 1; the input impedance is very large as well and determined by the input impedance of the OPAMP. The analysis of this circuit is straightforward if we take advantage of the virtual short principle. As shown in figure 3.20, the voltages at the inverting terminals are given by  $v_{i1}$  and  $v_{i2}$ , respectively. The current flowing through  $R1$  is then given by  $(v_{i1}-v_{i2})/R1$ ; this current flows throughout the resistors  $R_f$ , generating a voltage drop due to  $R_f$  given by  $(v_{i1}-v_{i2}) R_f / R1$ . The output voltage  $v_{o1}$  is then equal to  $v_{i1}+(v_{i1}-v_{i2}) R_f / R1$  while the output voltage  $v_{o2}$  is given by  $v_{i2}-(v_{i1}-v_{i2}) R_f / R1$ . The differential voltage gain is then computed as

$$\frac{v_{od}}{v_{id}} = \frac{v_{o1} - v_{o2}}{v_{i1} - v_{i2}} = 1 + \frac{2R_f}{R_1} \tag{3.33}$$

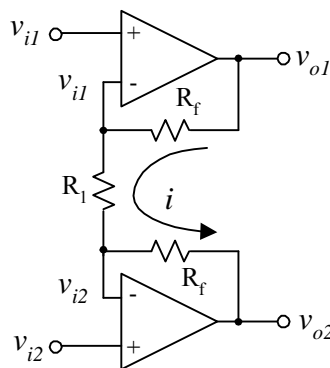

Fig. 3.20. Practical fully-differential instrumentation amplifier.

Notice in this expression that the output voltage is also differential  $v_{od}=v_{o1}-v_{o2}$ . Since the gain of the previous expression is defined as the ratio of the differential output voltage and the differential input  $v_{id}$  it is known as differential voltage gain.

Discuss here the properties of differential and common-mode signals.  
Common-mode input impedance and differential mode input impedance.

The most popular single-ended instrumentation amplifier is depicted in Fig. 3.21; this topology is very useful for instrumentation applications. There are two inputs, and the important information is in differential format  $v_{id}=v_{i1}-v_{i2}$ . A major advantage of fully-differential circuits is that they are little sensitive to noise and signal interferences that affect both inputs; e.g. common-mode signals. The single ended output then should be proportional to  $v_{id}$ , and signals that are present in both inputs with same amplitude and same phase are cancelled by the differential nature of the amplifier. Applying the superposition principle to the circuit shown in fig. 3.21, it can be shown that the output voltage is given by a linear combination of  $v_{o1}$  and  $v_{o2}$  as follows:

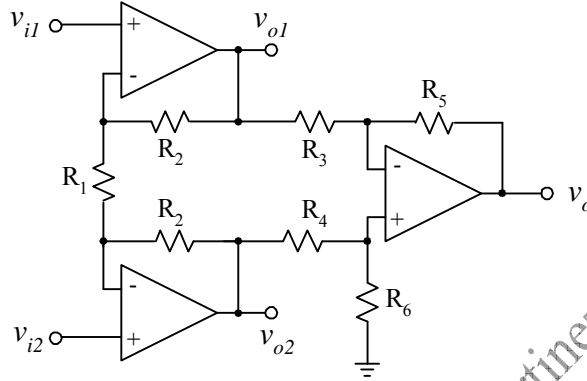

Fig. 3.21. Practical single-ended instrumentation amplifier.

$$v_o = \left(1 + \frac{R_5}{R_3}\right) \left(\frac{R_6}{R_4 + R_6}\right) v_{o2} - \left(\frac{R_5}{R_3}\right) v_{o1} \quad (3.34)$$

Using the previous equations 3.33 and 3.34, the output voltage can be obtained as

$$v_o = \left(\frac{R_6}{R_4 + R_6}\right) \left(1 + \frac{R_5}{R_3}\right) \left[\left(1 + \frac{R_2}{R_1}\right) v_{i2} - \frac{R_2}{R_1} v_{i1}\right] - \left(\frac{R_5}{R_3}\right) \left[\left(1 + \frac{R_2}{R_1}\right) v_{i1} - \frac{R_2}{R_1} v_{i2}\right] \quad (3.35)$$

After some algebra we get the following result:

$$v_o = \left[\left(\frac{R_6(R_3 + R_5)}{R_3(R_4 + R_6)}\right) \left(1 + \frac{R_2}{R_1}\right) + \left(\frac{R_5}{R_3}\right) \left(\frac{R_2}{R_1}\right)\right] v_{i2} - \left[\left(\frac{R_6(R_3 + R_5)}{R_3(R_4 + R_6)}\right) \left(\frac{R_2}{R_1}\right) + \left(\frac{R_5}{R_3}\right) \left(1 + \frac{R_2}{R_1}\right)\right] v_{i1} \quad (3.36)$$

If we introduce the conditions  $R_3=R_4$  and  $R_5=R_6$ , this equation simplifies to the required differential output

$$v_o = \left(\frac{R_5}{R_3}\right) \left(\frac{R_1 + 2R_2}{R_1}\right) (v_{i2} - v_{i1}) \quad (3.37)$$

The important properties of this amplifier are:

1. The **input impedance is extremely large** and determined by the OPAMP. Therefore, it can be easily connected to a number of sensors regardless the type of sensor's output impedance.
2. The **output voltage is sensitive to differential input voltage**  $v_{id}=v_{i1}-v_{i2}$ .
3. **Common-mode noise present at both terminals is rejected** by the differential nature of the topology. The ability to reject common-mode noise (electromagnetic interference present at both amplifier's inputs for

instance) by an amplifier is measured by the common-mode rejection ratio (CMRR) parameter, to be discussed in next sections.

### **III.6. Practical OPAMP limitations.**

Copyright protected material: J. Silva-Martinez, TAMU



## ELEN-325. Part III.b

### 7.- Design examples.

Workout some additional examples: e.g. fig. P3.19, Sedra-Smith 1<sup>st</sup> edition.

### 8.- Filters and other non-conventional circuits.

Filters are used in electronics for the selection of information that is located in a specific frequency band. A popular structure is the so-called multiple feedback topology shown in figure 3.1b. Two feedback paths can be observed in this circuit, the first one due to  $Y_4$  and the second one due to  $Y_5$ . Both feedback trajectories provide negative feedback, that makes the circuit is stable. The voltage gain of this structure can be found by solving the nodal equations at node  $v_x$  and the OPAMP's inverting terminal. Those equations can be written as (find it!):

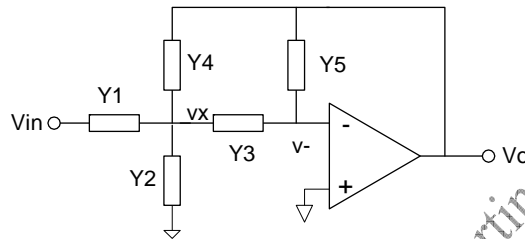

Fig. 3.1b. Multiple feedback second-order filter.

$$\begin{bmatrix} Y_1 + Y_2 + Y_3 + Y_4 & -Y_3 & -Y_4 \\ -Y_3 & Y_3 + Y_5 & -Y_5 \end{bmatrix} \begin{bmatrix} v_x \\ v_- \\ v_o \end{bmatrix} = \begin{bmatrix} Y_1 v_{in} \\ 0 \end{bmatrix} \quad (3.1b)$$

Please write the equations and check the matrix (don't believe in professor's result!). Solving the system of equations we should be able to find the output voltage of the circuit. Notice that we are not writing any equation for the output node of the OPAMP, and we should not! The OPAMP output voltage is generated by a voltage controlled voltage source, where the current demanded by the elements connected to the OPAMP is provided by that element. For ideal OPAMPs,  $v_o$  is controlled by the elements connected in feedback and the input voltage, and not by the elements connected at the OPAMP output! For the solution of the equations 3.1b make  $v_- = 0$  since we have a virtual ground at the input of the OPAMP.

We might write these equations by inspection noticing that:

1. For the **first row we consider the nodal equation at node  $v_x$** . For the element 11 of the admittance matrix we have to consider all the admittances connected to  $v_x$ ; since  $v_x$  is the first node we are considering. In fig. 3.1b, the elements connected to  $v_x$  are  $Y_1$ ,  $Y_2$ ,  $Y_3$ , and  $Y_4$ .
2. The 12 element of the matrix is determined as the negative of the admittance between  $v$  and  $v_-$ , since the second node considered in the admittance matrix is  $v_-$ .
3. The element 13 is the negative of the element(s) connected between  $v_x$  and  $v_o$ , in this case  $-Y_4$ .
4. For the **second row we considered the nodal equation at node  $v_-$** . Matrix term 21 is the negative of the admittance connected between  $v_-$  and  $v_x$ .
5. The element 22 is composed by all admittances connected to  $v_-$  (the node under consideration).
6. Finally the matrix term 23 is the negative of the admittances connected between  $v_-$  and  $v_o$ .
7. For the right hand side of 3.1b, we considered the input voltage and the admittance connected between  $v_{in}$  and  $v_x$ .
8. Since we do not have any element connected between  $v_-$  and  $v_i$  the second term of the right hand side is zero.

Another approach for finding the transfer function is using the properties of linear circuits. Applying superposition,  $v_x$  is a linear combination of  $v_{in}$  and  $v_o$ . Since the OPAMP inverting terminal is a virtual ground, computation of  $v_x$  yields (check it!)

$$v_x = \frac{Y_1}{Y_1 + Y_2 + Y_3 + Y_4} v_{in} + \frac{Y_4}{Y_1 + Y_2 + Y_3 + Y_4} v_o \quad (3.2b)$$

Also, notice that  $v_o$  is generated by  $Y_5$ ,  $Y_3$  and  $v_x$  as

$$v_o = -\frac{Y_3}{Y_5} v_x \quad (3.3b)$$

Solving those equations, the voltage gain can be found as:

$$H(s) = \frac{v_o}{v_{in}} = \frac{-Y_1 Y_3}{Y_5 (Y_1 + Y_2 + Y_3 + Y_4) + Y_3 Y_4} \quad (3.4b)$$

Both methods are useful.

A Particular case of this circuit is the **Second order LOW-PASS transfer function**. Replacing some of the admittances in Fig. 3.1b by the resistors and capacitors shown below, the circuit behaves as a second order lowpass filter. From equation 3.4b it can be found that

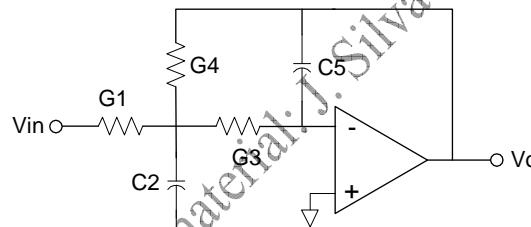

Fig. 3.2b. Multiple feedback Low-pass filter.

$$H(s) = \frac{-G_1 G_3}{s^2 C_5 C_2 + s C_5 (G_1 + G_3 + G_4) + G_3 G_4} \quad (3.5b)$$

The properties of this circuit are evident just analyzing the location of poles and zeros. There are two poles defined by the different components, and two zeroes at  $\omega = \infty$  (why?). Therefore, the magnitude response will remain relatively flat until the frequency of the dominant poles if real poles are implemented. For frequencies above the first (dominant) pole, the magnitude response decreases monotonically with a roll-off of  $-20$  dB/decade. Beyond the frequency of the second pole the roll-off becomes  $-40$  dB/decade due to the effect of the second pole, as shown in the figure below.

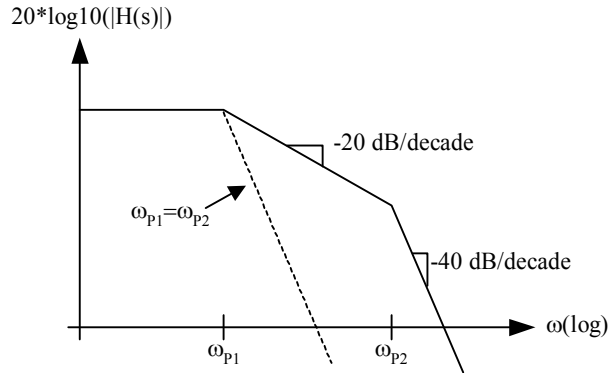

Fig. 3.3b. Magnitude response for a second order transfer function with two real poles.

For better rejection of high frequency components usually the poles are located close to each other as shown in the dashed curve; in this case the high-frequency rolloff of the magnitude response is  $-40$  dB/decade. For the design of a low-pass second order transfer it is more convenient to express equation 3.5b as

$$H(s) = -\left(\frac{G_1 G_3}{C_5 C_2}\right) \left( \frac{1}{s^2 + s \frac{(G_1 + G_3 + G_4)}{C_2} + \frac{G_3 G_4}{C_5 C_2}} \right) \quad (3.6b)$$

The poles of the system are determined by the denominator of the previous equation and can be obtained as

$$\omega_{p1,2} = -\left(\frac{G_1 + G_3 + G_4}{2C_2}\right) \left( 1 \pm \sqrt{1 - \frac{4 \frac{G_3 G_4}{C_5 C_2}}{\left(\frac{G_1 + G_3 + G_4}{C_2}\right)^2}} \right) = -\left(\frac{G_1 + G_3 + G_4}{2C_2}\right) \left( 1 \pm \sqrt{1 - \frac{4G_3 G_4 \left(\frac{C_2}{C_5}\right)}{(G_1 + G_3 + G_4)^2}} \right) \quad (3.7b)$$

Selecting the proper values for the components, the poles can be real or complex conjugate; the conditions for these cases are the following:

$$\omega_{p1,2} = \begin{cases} \text{Real if } \frac{4G_3 G_4 \left(\frac{C_2}{C_5}\right)}{(G_1 + G_3 + G_4)^2} \leq 1 \\ \text{Complex conjugated if } \frac{4G_3 G_4 \left(\frac{C_2}{C_5}\right)}{(G_1 + G_3 + G_4)^2} > 1 \end{cases} \quad (3.8b)$$

The phase response is also important for the full characterization of the low-pass filter. The inverting filter configuration has a phase shift of  $-180$  degrees at very low frequencies; this can be verified on the original transfer function, equation 3.6b, evaluating it at  $s=0$ . Each pole introduces a phase shift of  $-45$  degrees around its pole

frequency, as discussed in previous sections. If the poles are far away from each other, the phase response looks like the one depicted by the solid line in the following phase plot.

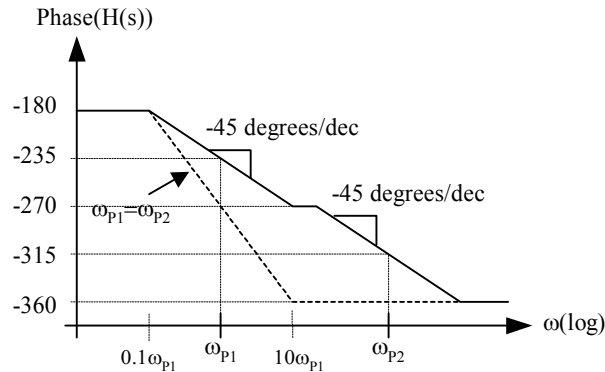

Fig. 3.4b. Phase response for an inverting second-order transfer function.

If the system have the two poles close to  $\omega_{p1}$ , then the system's phase response presents a roll-off of  $-90$  degrees/decade around  $\omega_{p1}$ , due to phase contribution of two poles, as shown in the dashed plot.

**The following design example will be discussed in class:**

Lowpass filter design: DC GAIN = 20 dB,  $\omega_{p1}=\omega_{p2}=100$  Krad/sec. The design equations are obtained from the desired filter's transfer function as follows:

$$H(s) = -\left(\frac{10\omega_1^2}{(s + \omega_{p1})(s + \omega_{p1})}\right) = -\left(\frac{10\omega_{p1}^2}{s + 2\omega_{p1}s + \omega_{p1}^2}\right)$$

Note that the numerator  $10\omega_{p1}^2$  is needed to obtain the desired DC voltage gain. Equation the terms of this equation with the ones of equation 3.6b, the design conditions are obtained

$$R_4/R_1=10$$

$$(10^5)^2=1/(R_3R_4C_2C_5)$$

$$2(10^5)=(1/R_1+1/R_3+1/R_4)/C_2$$

Lets design the filter based on power consumption considerations. To avoid the use of very small resistors, which implies very large currents and more power consumption, lets fix the smaller resistor to  $R_1=10$  k $\Omega$  and to use  $R_3=R_4$ . Hence:

$$R_3=R_4=100$$
 k $\Omega$

$$C_2C_5=1/(10^{10} \times 10^{10})=10^{-20}$$

$$C_2=(1.2 \times 10^{-4}) / (2 \times 10^5)=0.6 \times 10^{-9}$$

Then  $C_5=10^{-20}/0.6 \times 10^{-9}=16.6 \times 10^{-12}$ . The final design is shown below. The circuit has been simulated in PSPICE, the magnitude and phase response are also shown.

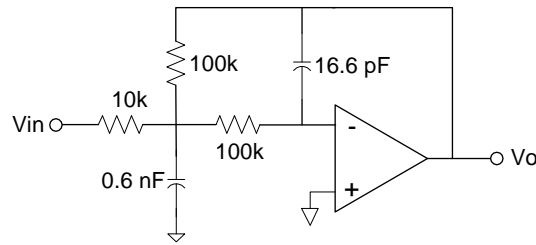

Component values for the LOWPASS filter

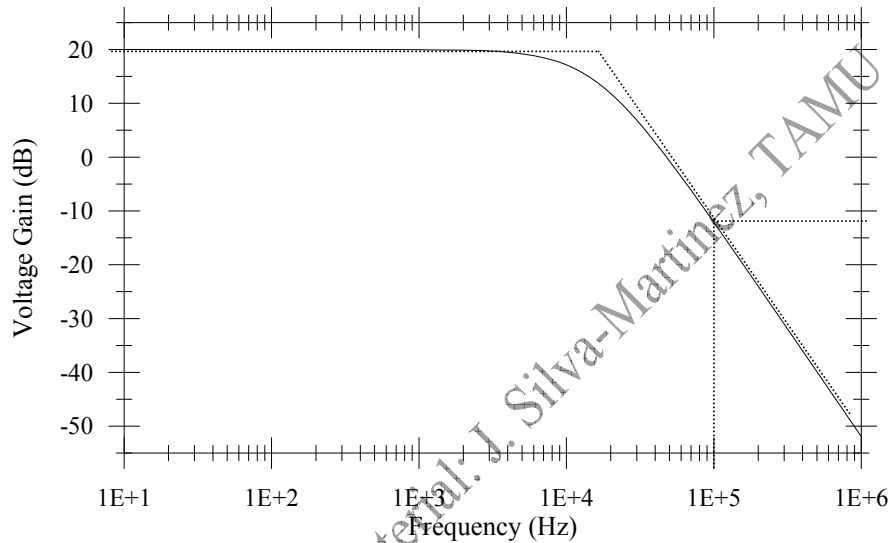

Spice Results: Magnitude response

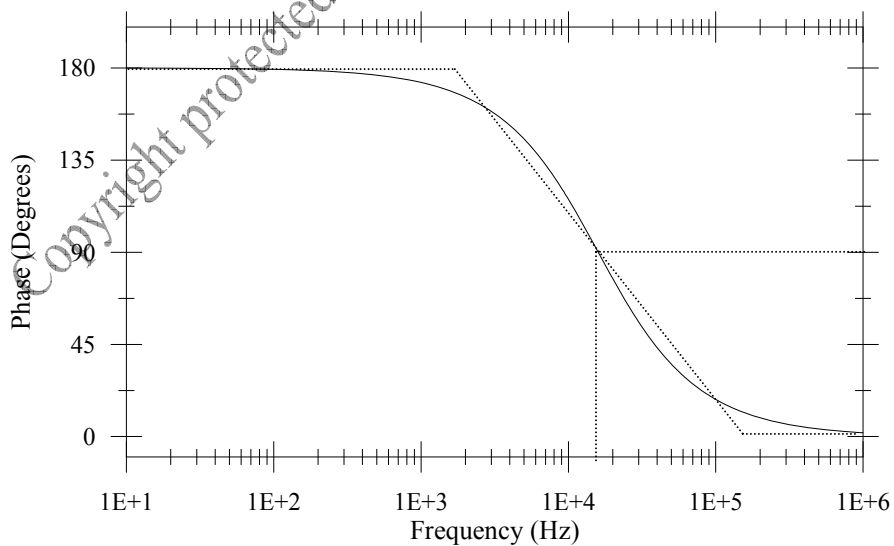

Spice Results: Phase response

**Relationship between frequency domain and time domain.** In many cases we are more interested into see the response of the circuit in time domain; e.g. impulse and/or pulse response. An approach for the analysis of a circuit

in time domain is to write the nodal or mesh equations in time domain using the integro-differential equations for capacitors and inductors. Another approach is to obtain the transfer function in the frequency domain as in the previous examples and to convert it into a differential equation by using the properties of the laplace transform. Among many other properties of the laplace transform, one of the fundamental ones is the following:

$$\ell\left(\sum_{i=0}^N a_i \left(s^i x\right)\right) = \sum_{i=0}^N a_i \frac{d^i x(t)}{dt^i} \quad (3.9b)$$

This property of the laplace transform is used for the conversion of rationale linear functions in the s-domain to the differential equation in the t-domain. To illustrate its use, let us consider the following s-domain (frequency domain) lowpass transfer function:

$$\frac{v_o(s)}{v_{in}(s)} = \frac{-a_0}{s^2 + b_1 s + b_0} \quad (3.10b)$$

It can also be re-written as

$$\left(s^2 + b_1 s + b_0\right)v_o(s) = -a_0 v_{in}(s) \quad (3.11b)$$

if the laplace transform is applied to both sides of this equation, the time-domain equivalent is obtained leading to the following second-order differential equation

$$\frac{d^2}{dt^2}(v_o(t)) + b_1 \frac{d}{dt}(v_o(t)) + b_0 v_o(t) = -a_0 v_{in}(t) \quad (3.12b)$$

The next step is to solve this equation taking into account the type of input signal; e.g. impulse response, pulse response or even sinusoidal input response. It is not the purpose of this chapter to discuss the time domain analysis, and the student should be referred to more specialized books for detailed analysis and more examples.

**Bandpass transfer function.** Very often the information to be processed is within a given pass band, hence lowpass and high pass filtering might not be the most efficient approach for signal detection. A bandpass filter is more suitable for this purpose; it can be obtained if in addition to the two poles of the lowpass transfer function, one of the zeros is located at low frequency and the other one at very high frequencies. These zeros can be easily implemented if they are located at  $\omega=0$ , and  $\omega=\infty$ , respectively. If the general multiple feedback transfer function, equation 3.4b, is considered the zero at low frequencies is generated if one of the two elements Y1 or Y3 is replaced by a capacitor while the other one is a conductance, respectively. A suitable option for filter realization is shown in the following figure. The analysis of this circuit is similar to the one used for the lowpass filter; the transfer function is

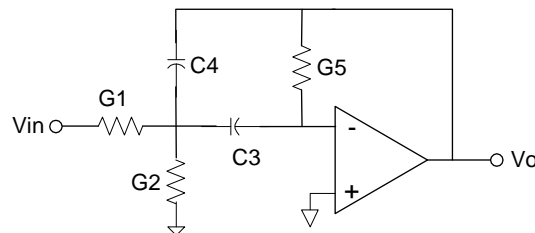

Fig. 3.5b. Multiple feedback band-pass filter.

$$H(s) = \frac{-sG_1C_3}{s^2C_3C_4 + sG_5(C_3 + C_4) + (G_1 + G_2)G_5} = -\left(\frac{G_1}{C_4}\right) \left( \frac{s}{s^2 + s\frac{G_5(C_3 + C_4)}{C_3C_4} + \frac{(G_1 + G_2)G_5}{C_3C_4}} \right) \quad (3.13b)$$

The resulting transfer function has two zeros, one at DC and the other one (phantom) at  $\omega=\infty$ . If the poles are at the same frequency, the magnitude and phase responses can be approximated by piece wise linear functions as depicted in the following plots.

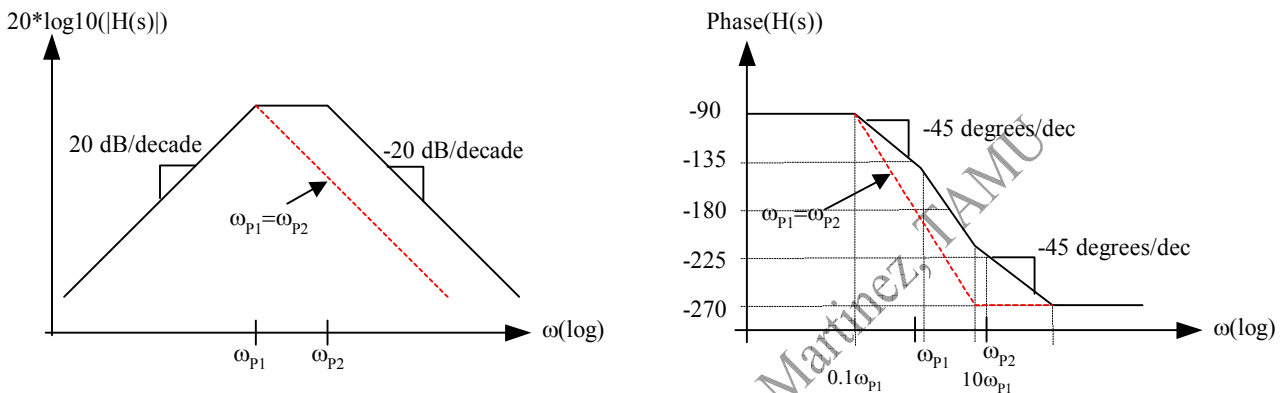

Fig. 3.6b. Magnitude and phase response of a second order bandpass transfer function.

**Exercise:** Design a Bandpass filter with both poles at 50 MHz and peak gain of 0 dB. Do it!

### 10.- Partial positive feedback.

**10.1 Resistive amplifiers with partial positive feedback.** Partial positive feedback can also be used for the implementation of demanding applications. For instance, negative resistors have to be used for the design of voltage controlled oscillators to cancel the effects of resistors lumped to inductors and capacitors (resistive losses). In partial positive feedback circuits, both terminals inverting and non-inverting are embedded in feedback loops; an example is the circuit shown in Fig. 3.7b. The voltage at the positive terminal is a sample of the output voltage  $v_o$ , and then it can be found that

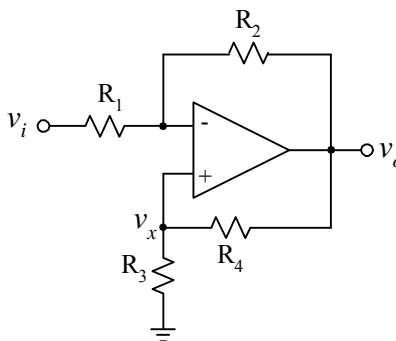

Fig. 3.7b. Resistive amplifier with negative and positive feedback

$$v_x = \frac{R_3}{R_3 + R_4} v_o \quad (3.14b)$$

The output voltage is composed by the contribution of  $v_i$  (inverting amplifier with a voltage gain  $=-R_2/R_1$ ) and  $v_x$  (non-inverting amplifier given by  $(1 + R_2/R_1)v_x$ ). Hence, the output voltage can be obtained as:

$$v_o = \left(1 + \frac{R_2}{R_1}\right) v_x - \left(\frac{R_2}{R_1}\right) v_i = \left(\frac{R_3}{R_3 + R_4}\right) \left(1 + \frac{R_2}{R_1}\right) v_o - \left(\frac{R_2}{R_1}\right) v_i \quad (3.15b)$$

The solution of this expression for output voltage yields;

$$v_o = - \left( \frac{\frac{R_2}{R_1}}{1 - \left(\frac{R_3}{R_1}\right) \left(\frac{R_1 + R_2}{R_3 + R_4}\right)} \right) v_i \quad (3.16b)$$

The positive feedback is reflected in the negative term of the denominator. The voltage gain can be further increased if  $R_3(R_1+R_2)/(R_1(R_3+R_4))$  is close to unity. Notice that the gain can potentially be infinite. This situation is undesirable because a small variation in any of the components has a huge impact on the overall voltage gain; these variations could be due to temperature variations or aging of the components. Thus, if positive feedback is used, be sure that negative feedback is dominant and that variations on components do not drastically affects circuit's performances.

#### Realization of negative impedances.

The circuit shown below uses partial positive feedback as well since the  $R_4$  links the output voltage and the non-inverting terminal. To understand the operation of the circuit, let us find the voltage at the non-inverting terminal. Applying superposition,  $v_x$  is composed by the contribution of  $v_i$  and  $v_o$ . The first component can be obtained by considering  $v_i$ , and grounding  $v_o$ ; this can be done because the output of the OPAMP is a low-impedance node, and  $v_o$  is defined by the voltages applied at the OPAMP inputs. The second component is obtained by considering  $v_o$  and grounding  $v_i$ , then

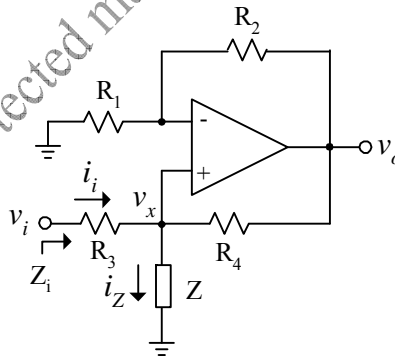

3.8b. Amplifier with partial positive feedback.

$$v_x = \frac{R_4 // Z}{R_3 + R_4 // Z} v_i + \frac{R_3 // Z}{R_3 // Z + R_4} v_o \quad (3.17b)$$

Once this voltage is obtained, the output voltage can be easily determined, because



$$v_o = \left(1 + \frac{R_2}{R_1}\right) v_x = \left(1 + \frac{R_2}{R_1}\right) \left( \frac{R_4 // Z}{R_3 + R_4 // Z} v_i + \frac{R_3 // Z}{R_3 // Z + R_4} v_o \right) \quad (3.18b)$$

After some algebra we can find the overall transfer function as

$$\frac{v_o}{v_i} = \frac{\left(1 + \frac{R_2}{R_1}\right) \left( \frac{R_4 // Z}{R_3 + R_4 // Z} \right)}{1 - \left(1 + \frac{R_2}{R_1}\right) \left( \frac{R_3 // Z}{R_3 // Z + R_4} \right)} \quad (3.19b)$$

Once again, the positive feedback is reflected in the negative term of the denominator. An important special case is when  $R_1=R_2$  and  $R_3=R_4$ ; the previous equations can be simplified as follows:

$$\frac{v_o}{v_i} = \frac{2(R_3 // Z)}{R_3 - (R_3 // Z)} = \frac{2Z}{R_3} \quad (3.20b)$$

Therefore, the circuit behaves as a non-inverting amplifier. The most interesting properties of this circuit are associated with the input impedance. From 3.17b, it is obtained for the case  $R_1=R_2$  and  $R_3=R_4$  that

$$v_x = \left( \frac{Z}{R_3 + 2Z} \right) (v_i + v_o) = \left( \frac{Z}{R_3 + 2Z} \right) \left( 1 + \frac{2Z}{R_3} \right) v_i = \left( \frac{Z}{R_3} \right) v_i \quad (3.21b)$$

Therefore the current flowing throughout  $Z$  can now be obtained as

$$i_Z = \frac{v_x}{Z} = \frac{v_i}{R_3} \quad (3.22b)$$

As can be noticed in this result, the current flowing through  $Z$  is determined by  $R_3$ ; this current is independent of  $Z$ . Therefore, this circuit can be considered as a voltage controlled current source; the current is controlled by the input voltage and the resistors  $R_3=R_4$ , and this current is forced to flow through  $Z$ . On the other hand, the impedance at the input port is determined as follows (please work out the following expression).

$$Z_i = \frac{v_i}{i_i} = \frac{R_3^2}{R_3 - Z} \quad (3.23b)$$

For  $Z < R_3$  the input impedance is positive, and negative for  $Z > R_3$ .

A useful circuit often used in filter's design is the negative impedance converter. The circuit, shown in Fig. 3.9b, is a variation of the schematic depicted in Fig. 3.8b. The input voltage is applied to the non-inverting terminal, and the output voltage  $v_o$  is given by  $(1+R_2/R_1)v_i$ . The input current  $i_i$  is computed as  $(v_i - v_o)/Z$ , leading to the result given in expression 3.24b.

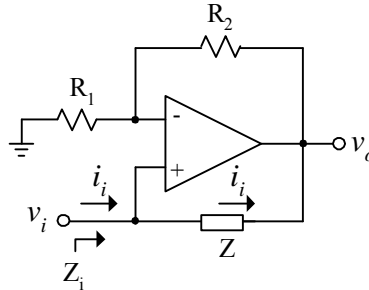

Fig. 3.9b. Negative impedance converter.

$$Z_i = \frac{v_i}{i_i} = \frac{v_i}{v_i - v_o} Z = -\left(\frac{R_1}{R_2}\right) Z \tag{3.24b}$$

Therefore, the equivalent impedance is negative. A negative impedance means that, contrary to the case of a positive impedance, the circuit delivers current when positive signals are applied. The reason for this behavior is that the OPAMP altogether with  $R_1$  and  $R_2$  amplify the input and the output voltage is greater or equal than  $v_i$ . Hence positive  $v_i$  generates  $v_o > v_i$ ; since  $Z$  is connected between them it generates a current that flows from  $v_o$  to  $v_i$ .

Think about the following questions:

**What is the meaning of negative impedance?**

**Difference between positive and negative impedance?**

**10.2. Sallen & Key Filter.** Positive feedback has been used for the design of filters for long time. The filter based on finite gain amplifier uses 5 admittances and an amplifier with finite gain  $K$ . Since the amplifier is a non-inverting structure, the feedback produced by  $Y_2$  is positive leading to a filter with partial positive feedback. By following the analysis procedure used for the multiple feedback filters, the transfer function can be obtained by written the admittance matrix as follows:

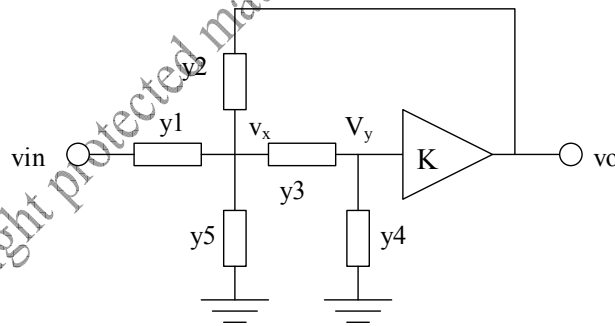

Fig. 3.10b. Sallen and Key second-Order filter.

$$\begin{bmatrix} y_1 + y_2 + y_3 + y_5 & -y_3 & -y_2 \\ -y_3 & y_3 + y_4 & -0 \\ -0 & -K & 1 \end{bmatrix} \begin{bmatrix} v_x \\ v_y \\ v_o \end{bmatrix} = \begin{bmatrix} y_1 v_{in} \\ 0 \\ 0 \end{bmatrix} \tag{3.25b}$$

The first two rows correspond to the nodal equations of nodes  $v_x$  and  $v_y$ , respectively. The third row corresponds to the finite amplifier gain given by  $v_o = K v_y$ . The solution of this system leads to the following filter's transfer function:

$$H(s) = \frac{y_1 y_3 K}{(y_1 + y_2 + y_5)(y_3 + y_4) + y_3(y_4 - y_2 K)} \tag{3.26b}$$

Selecting the proper elements lowpass, bandpass and highpass filters can be designed. These especial cases are:

- Selecting Y1 and Y3 as conductances, and Y2 and Y4 as capacitive admittances, the resulting transfer function leads to a lowpass transfer function. Even more, Y5 might be removed in this case; the resulting filter is shown in the figure below. Equation 3.27b show the transfer function.

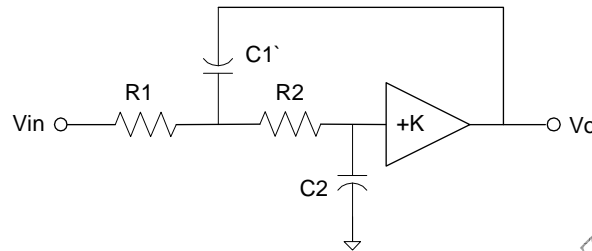

Fig. 3.11b. Second order Sallen and Key Filter. Notice that this filter uses partial positive feedback

$$H(s) = \frac{K \left( \frac{1}{R_1 R_2 C_1 C_2} \right)}{s^2 + s \left( \frac{1}{R_1 C_1} + \frac{1}{R_2 C_1} + \frac{1}{R_2 C_2} (1-K) \right) + \frac{1}{R_1 R_2 C_1 C_2}} \tag{3.27b}$$

Similarly it can be shown that

- Y1 and Y4 conductances, and Y3 and Y5 capacitors lead to a bandpass transfer function.
- Y2 and Y4 conductances, and Y1 and Y2 capacitors lead to a high-pass transfer function.

**Find yourself the resulting circuits! You may find one of these topologies in the first midterm.**

**11. Practical Limitations of the Operational Amplifiers.** First at all, we must recognize that practical OPAMP are not even close to the ideal model: infinite input impedance, infinite gain, infinite bandwidth, and unlimited output current capability. Those parameters depends on the topology used (array of transistors, resistors and capacitors, technology used and power consumption); there are tons of different OPAMPs offered by different vendors; eg. Texas Instruments, Fairchild, National Semiconductor, etc. Although the origin of those limitations are not discussed in this course, the effects of on the overall transfer function of these parameters are briefly discussed in this section.

A more realistic OPAMP macromodel is depicted in the following schematic.

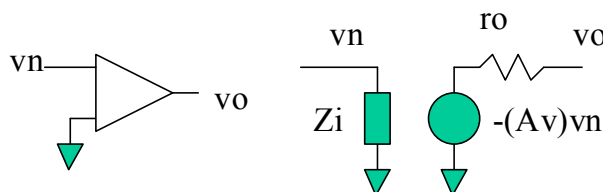

Figure 3.12b. Macromodel for the OPAMP.

Some values for commercially available OPAMPs are:  $Z_i = 1M\Omega$ ,  $r_o = 10\Omega$ , and  $A_v = 10^5$ . These parameters introduce errors in the transfer function. Usually it is cumbersome to obtain the final results, and it is difficult to evaluate

system degradation especially for complex circuits. Here we obtain some results for a single inverting amplifier but most of the conclusions for this circuit are also valid for complex circuits. Let us consider the circuit shown in Figure 3.13b; we are considering the finite input impedance of the OPAMP  $Z_i$  and the input impedance of the stage driven by the OPAMP. Using the macromodel of Fig. 3.12b with  $r_0=0$ , the equivalent circuit can be obtained as depicted in Figure 3.13 (b). The transfer function can be obtained if the nodal equation at node  $v_-$  is written; notice that nodal equation at the OPAMP output can not be written because  $v_o$  is controlled by the voltage dependent voltage source ( $v_o=A_v(v_+-v_-)$ ). The current demanded by  $Z_F$  and  $Z_L$  is provided by the ideal voltage source. Solving the fundamental equation ( $i_1=i_i+i_0$ ) the circuit's transfer function yields,

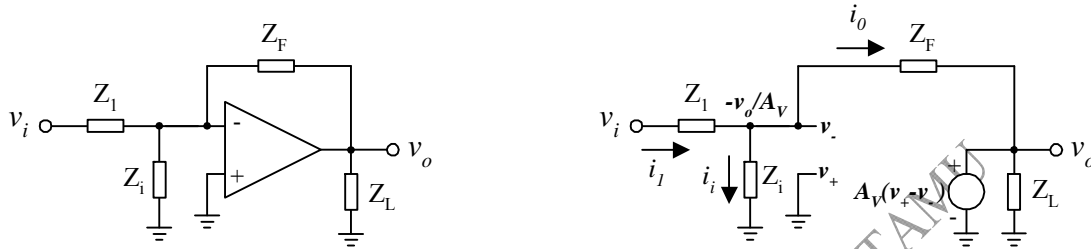

Fig. 3.13b. a) Inverting amplifier with OPAMP input impedance  $Z_i$  and load impedance  $Z_L$ , and b) equivalent circuit with  $r_0=0$ .

$$H(s) = -\left(\frac{Z_F}{Z_i}\right) \left( \frac{1}{1 + \frac{(Z_F/Z_1) + (Z_F/Z_i)}{A_v}} \right) \quad (3.29b)$$

The effect of the finite DC gain and finite input impedance on the inverting amplifier can be better appreciated if the error function is considered; from equation 3.29b it follows that

$$H(s) = -\left(\frac{Z_F}{Z_i}\right) \left( \frac{1}{1 + \xi} \right) \cong -\left(\frac{Z_F}{Z_i}\right) (1 - \xi) \quad (3.30b)$$

where the error function  $\xi$  is defined as

$$\xi(s) = \frac{(Z_F/Z_1) + (Z_F/Z_i)}{A_v} = \left( \frac{1}{A_v} \right) \left( \frac{Z_F}{Z_1 \parallel Z_i} \right) \quad (3.31b)$$

If the OPAMP DC gain is limited, the assumption of virtual ground is not longer valid since any output voltage variation generates a finite variation on the differential input signal given by  $v_o/A_v$ . The smaller the OPAMP gain the larger the voltage variations at the OPAMP input are; hence the error should be inversely proportional to  $A_v$ . The voltage variations on the non-inverting terminal lead to current errors: firstly the input current is given by  $(v_i-v_-)/Z_1$  hence an error proportional to  $Z_1$  ( $i_{error1} = -v_-/Z_1$ ) is introduced; Secondly, the OPAMP input impedance takes part of the current generated by  $Z_1$ , leading to a second current error given by  $i_{error2} = v_-/Z_i$ . These current errors are converted into voltage errors by the feedback resistor  $R_F$ , and are evident in equation 3.31b.

Notice that even if the OPAMP input impedance is infinite, a gain error due proportional to the ideal gain  $Z_F/Z_1$  is present. For a given OPAMP open-loop gain  $A_v$ , the larger the closed-loop amplifier's gain the larger the error is. The error that can be tolerated depends on the applications; notice that to keep the error below 1 % for instance it is required to satisfy

$$\xi(s) = \left( \frac{1}{A_v} \right) \left( \frac{Z_F}{Z_1 \parallel Z_i} \right) < 0.01 \quad (3.32b)$$

For instance if  $Z_i=1 \text{ M}\Omega$ , and voltage gain of  $-10$ , the voltage gain needed depends on the absolute values of the resistors used, as shown in table below

$Z_F/Z_i$	$A_v$
100/10	> 1000
10k/1k	> 1001
1M/100k	>1100
10M/1M	>2000

Notice that the errors are important when the input impedance  $Z_1$  is comparable with the OPAMP input impedance  $Z_i$ . Another important limiting factor is of course the desired amplifier gain  $Z_F/Z_i$ . Notice that 3.31b can also be rewritten as

$$\xi(s) = \left( \frac{1}{A_v} \right) \left( \frac{Z_F}{Z_1} \right) \left( \frac{Z_1 + Z_i}{Z_i} \right) \quad (3.33b)$$

**Effects of the OPAMP Finite bandwidth.** Unfortunately the OPAMP bandwidth is very limited; believe or not, the bandwidth of the 741 is around 6 Hz only while the open-loop DC gain is around  $2 \times 10^5 \text{ V/V}$ . The product of the open-loop DC gain and bandwidth is defined as OPAMP's Gain-BandWidth product GBW. For the OPAMP 741,  $\text{GBW} \sim 1.2 \text{ MHz}$ . These parameters are illustrated in the following plot

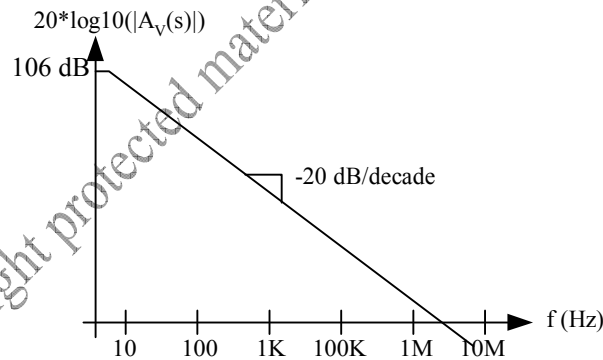

Fig. 3.14b. Typical open-loop magnitude response of an OPAMP

The OPAMP open-loop voltage gain can be modeled by a finite DC gain and a low-frequency pole as

$$A_v(s) = \frac{A_{DC}}{1 + \frac{s}{\omega_p}} \quad (3.34b)$$

Notice that  $\text{GBW} = A_{DC} \times \omega_p$ ; it is also known as the unity gain frequency  $\omega_u$ . This frequency is important because it defines the upper limit for the operation of the OPAMP: beyond this frequency the OPAMP is not longer an amplifier but an attenuator. That does not mean that you can always use the OPAMP until  $\omega_u$ ! Usually the useful frequency range is well below this limit. We learn in the previous discussion that an error is introduced if the open-

loop gain of the OPAMP is finite. For the inverting configuration, the error determined by equation 3.33b. If  $A_v$  is frequency dependent, then using 3.34b we can obtain a general form for the error function including the effects of the finite OPAMP bandwidth as shown in the following expression:

$$\xi(s) = \left[ \left( \frac{1}{A_{DC}} \right) \left( \frac{Z_F}{Z_1} \right) \left( \frac{Z_1 + Z_i}{Z_i} \right) \right] \left( 1 + \frac{s}{\omega_P} \right) \tag{3.33b}$$

Therefore, the pole of the OPAMP leads to a zero for the error transfer function as shown below. Therefore, the higher the bandwidth the larger the error is.

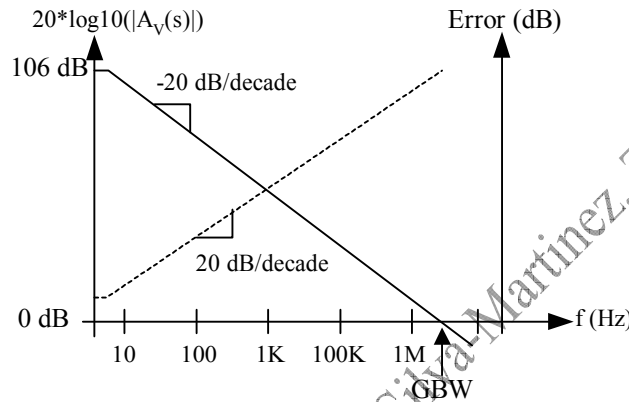

Fig. 3.15b. OPAMP open-loop magnitude response and error response for an inverting amplifier.

For the example discussed on the previous section we have:  $A_{DC}=10^5$  v/v,  $Z_F/Z_1=10$ ,  $Z_i=1M\Omega$  then it follows:

$Z_1/Z_i$	$\omega/\omega_P$	error
0.001	0.01	$\sim 10^{-4}$
0.001	1	$\sim 1.4 \times 10^{-4}$
0.001	10	$\sim 10^{-3}$
0.001	100	$\sim 10^{-2}$
0.001	1000	$\sim 10^{-1}$
0.01	100	$\sim 10^{-2}$
0.1	100	$\sim 10^{-2}$
1	100	$\sim 2 \times 10^{-2}$

Notice that the error increases further for high frequency applications. This is a result of the limited bandwidth of the OPAMP; we have to remember that the open-loop voltage gain reduces proportional to the frequency. The error is less than 1 % if and only if the frequency of the applied signal is below 100 times the OPAMP pole's frequency. For the OPAMP 741;  $f_p=6$  Hz; hence the signal's frequency has to be less than 600 Hz for an ideal amplification factor of -10.

The effects of the OPAMP finite input impedance are not very relevant if the used impedances  $Z_1$  and  $Z_F$  are lesser than  $Z_i/10$ .

- Slew-rate limitations: will be discussed in class.
- Common-mode signals: will be discussed in class.