

MultiSim, Analog Discovery 2, and Keysight Oscilloscope Manual

1 MultiSim

1.1 Running Windows Programs Using Mac

- Obtain free Microsoft Windows from:
<http://software.tamu.edu>
- Set up a Windows partition on your Mac:
<https://support.apple.com/en-us/HT204009>
- Install Windows on your Mac with Boot Camp:
<https://support.apple.com/en-us/HT201468>

1.2 Installation

- Purchase (at zero cost) "LabVIEW System Design" and "Circuit Design Suite Pro" from:
<http://software.tamu.edu>
- Follow the installation instructions you receive by email
- Use your TAMU email when creating your NI account
- Make sure you install LabView BEFORE you install MultiSim

1.3 Online Access through VOAL

- Using a web browser, go to <https://connect.voal.tamu.edu>

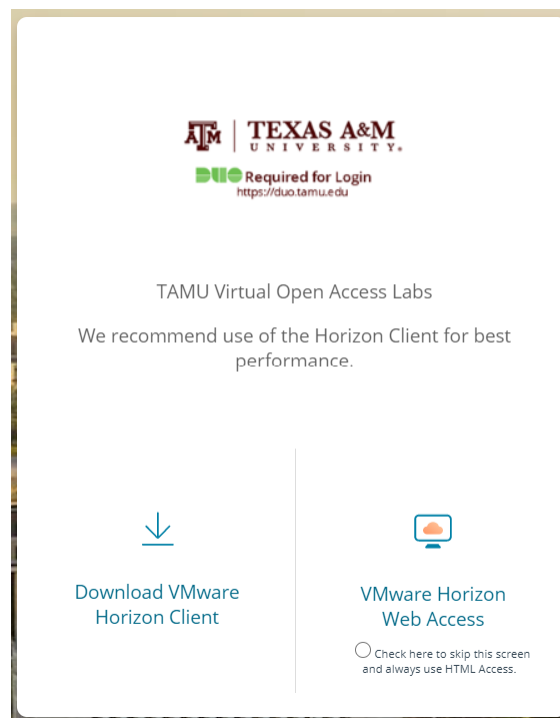

Figure 1: TAMU VOAL web page

- Click on "VMware Horizon Web Access" and login using your TAMU NetID and password (Fig. 1)

- Click on "NI MultiSim" on the next page (Fig. 2)

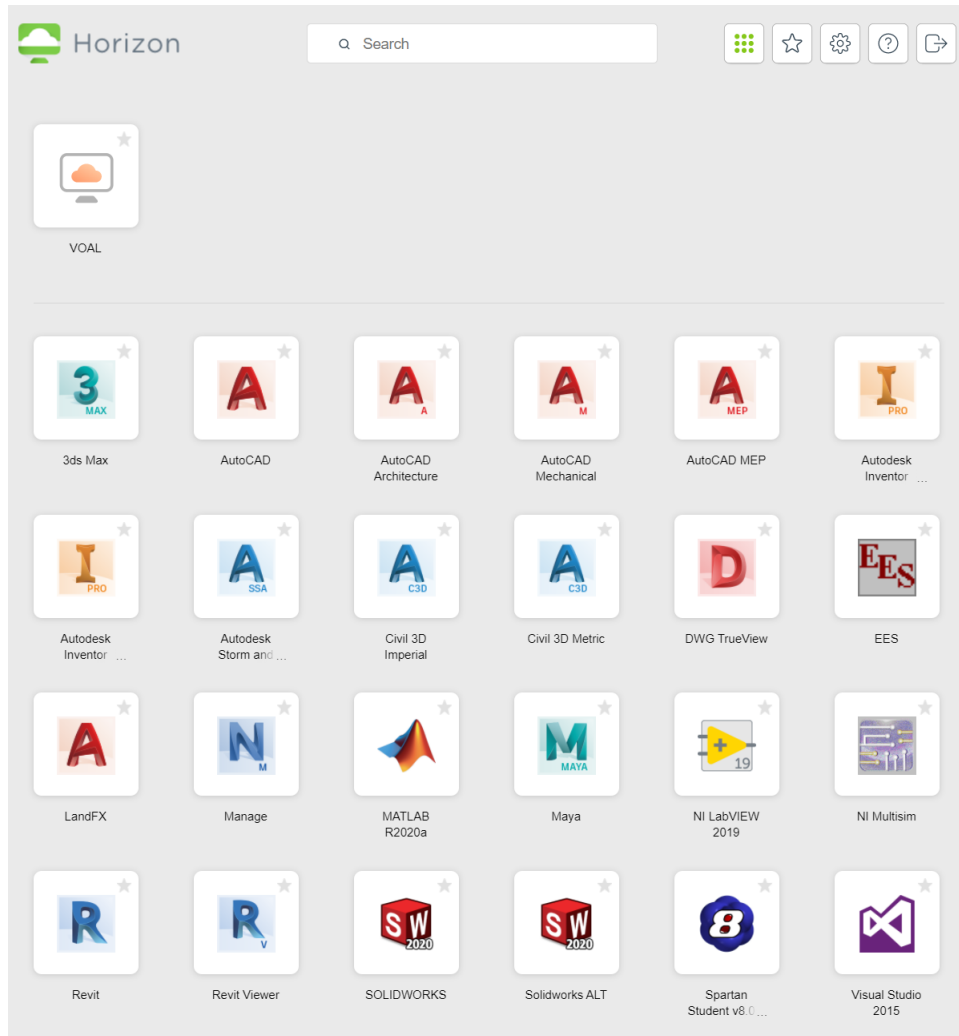

Figure 2: VMware Horizon Web Portal

- Alternatively, you can download and install VMware Horizon Client (see Fig. 1) to your PC, but you will still need internet connection to run MultiSim.

1.4 Schematics Editor

- Open the schematics Editor (Start → NI MultiSim 14.2)
- Insert components using the buttons in Fig. 3

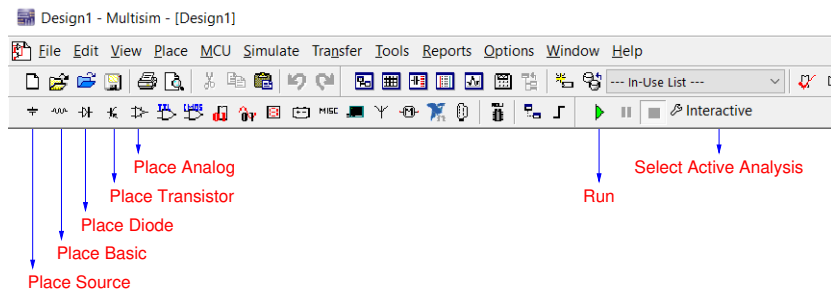

Figure 3: MultiSim schematic editor buttons

- **Place Source:** Voltage and current sources
 - **Place Basic:** Resistors, capacitors, and other basic components
 - **Place Analog:** Opamps and other analog circuit blocks
 - **Place Diode:** Diodes
 - **Place Transistor:** Transistors
- To connect two terminals, left click on one terminal, then the other one. Alternatively, use "Place → Wire" from the main menu.
 - Double click on the wires to label them. After writing the net name, check "Show net name", then click "OK".

1.5 Adding User Database (CD4007N, CD4007P and 2N7000G Transistors)

- Download the file "UsrComp_S_ECEN.usr" to a folder
- Click on Options → Global Options

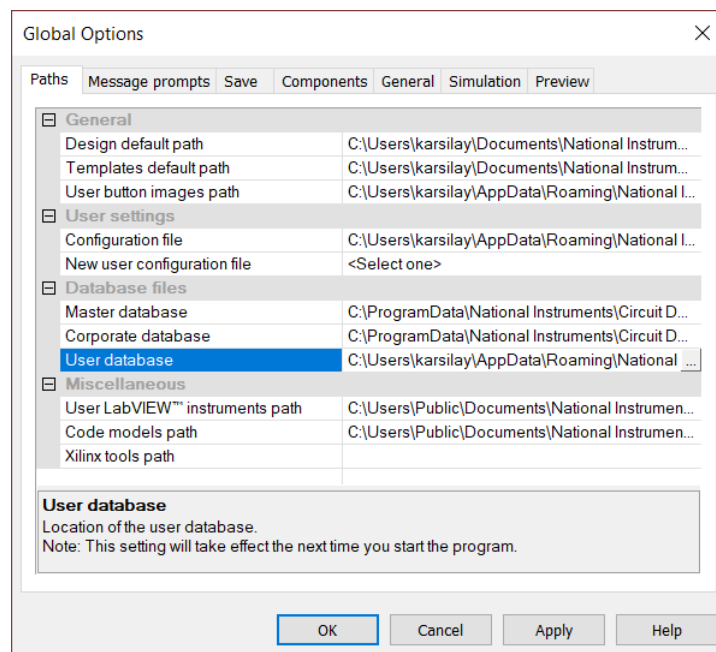

Figure 4: MultiSim global options

- In the Global Options window (see Fig.4), click on "User database", then click on ...
- Find the file "UsrComp_S_ECEN.usr", click on "Open", then "OK"
- Click on "Place transistor" in Fig. 3
- Select "User Database" on the top left corner
- Place MOS → CD4007N, CD4007P and 2N7000G

1.6 Bode Plots (AC Simulation)

- Click on "Select Active Analysis" in Fig. 3, then click on "AC Sweep" (Fig. 11)

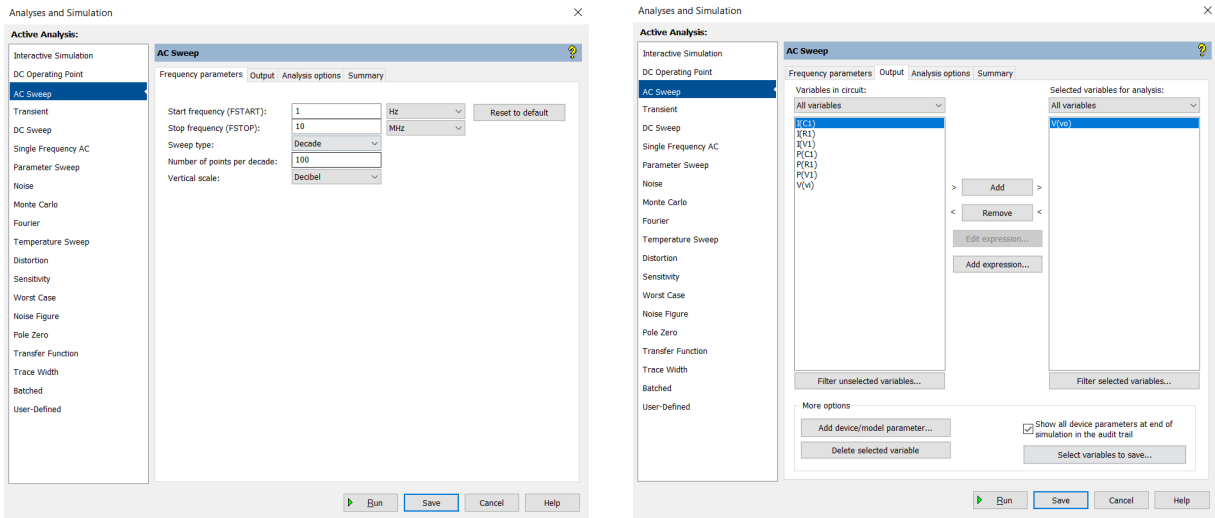

Figure 5: AC simulation setup

- On the "Frequency Parameters" tab, select:
 - Start frequency (FSTART): 1 Hz
 - Stop frequency (FSTOP): 10 MHz
 - Sweep type: Decade
 - Number of points: 100
 - Vertical scale: Decibel
- On the "Output" tab, click on "V(Vo)", then "Add", then "Save"
- Click on "Run" in Fig. 3

1.7 Time-Domain Waveforms (Transient Simulation)

- Click on "Select Active Analysis" in Fig. 3, then click on "Transient" (Fig. 6)

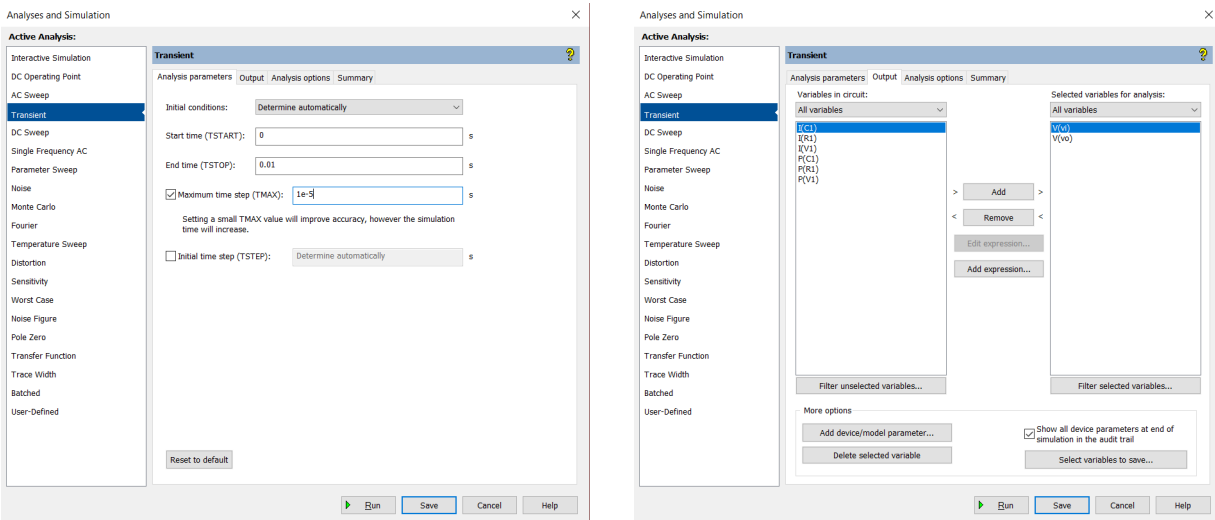

Figure 6: Transient simulation setup

- Calculate $T = 1/f_i$, where f_i is the input frequency
- On the "Analysis Parameters" tab, select:
 - Start time (TSTART): 0
 - End time (TSTOP): $10T$
 - Check "Maximum time step (TMAX)" and enter the value: $\frac{T}{100}$
- On the "Output" tab, click on "V(Vi)" and "V(Vo)", then "Add", then "Save"
- Click on "Run" in Fig. 3

1.8 Total Harmonic Distortion (Fourier Simulation)

- Click on "Select Active Analysis" in Fig. 3, then click on "Fourier" (Fig. 7)

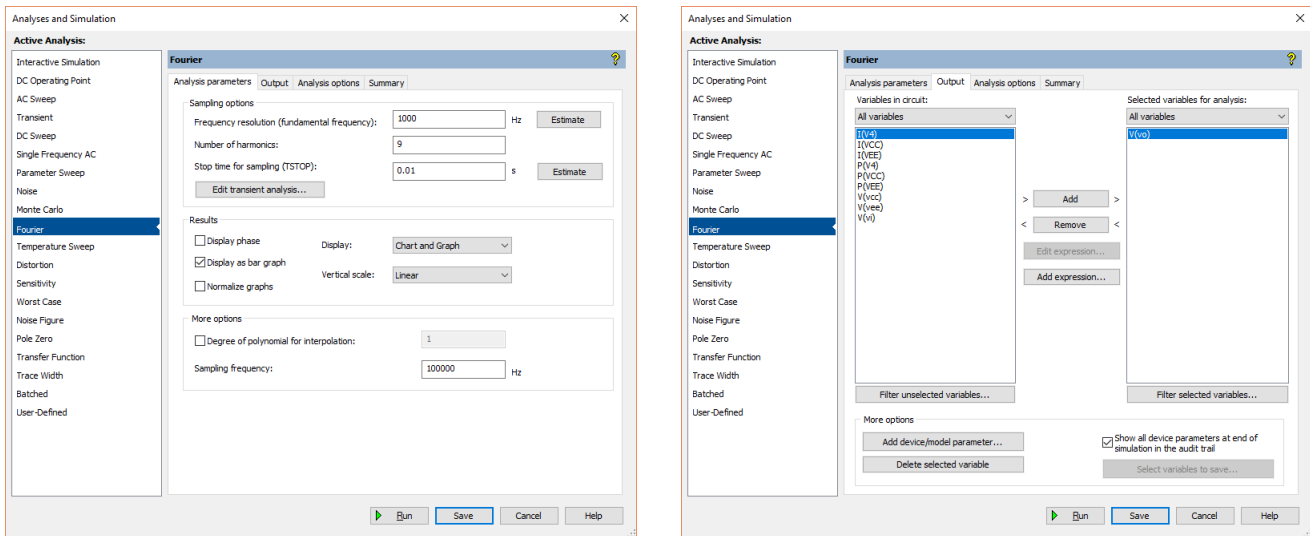

Figure 7: Fourier simulation setup

- Calculate $T = 1/f_i$, where f_i is the input frequency, and set $N = 9$
- On the "Analysis Parameters" tab, select:
 - Frequency resolution (fundamental frequency): f_i
 - Number of harmonics: N
 - Stop time for sampling (TSTOP): $10T$
- Click on "Edit transient analysis", select:
 - Start time (TSTART): 0
 - End time (TSTOP): $10T$
 - Check "Maximum time step (TMAX)" and enter the value: $\frac{T}{100(N+1)}$
- On the "Output" tab, click on "V(Vo)", then "Add", then "Save"
- Click on "Run" in Fig. 3

1.9 Input Resistance (AC Simulation)

- Identify the label of the input voltage source: **V1** in Fig. 8(a)
- Make sure that the "AC analysis magnitude" of V1 is set to 1 as in Fig. 8(b)

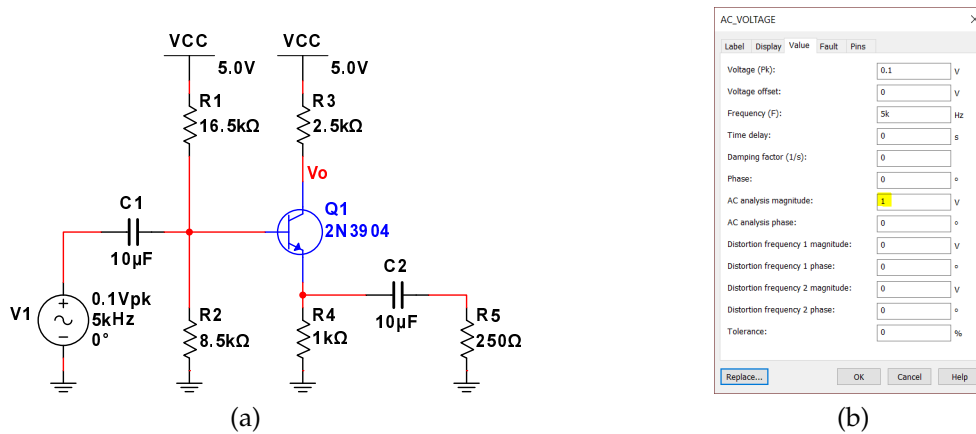

Figure 8: (a) Amplifier circuit for R_i simulation (b) Input voltage source properties

- Click on "Select Active Analysis" in Fig. 3, then click on "AC Sweep" (Fig. 11)

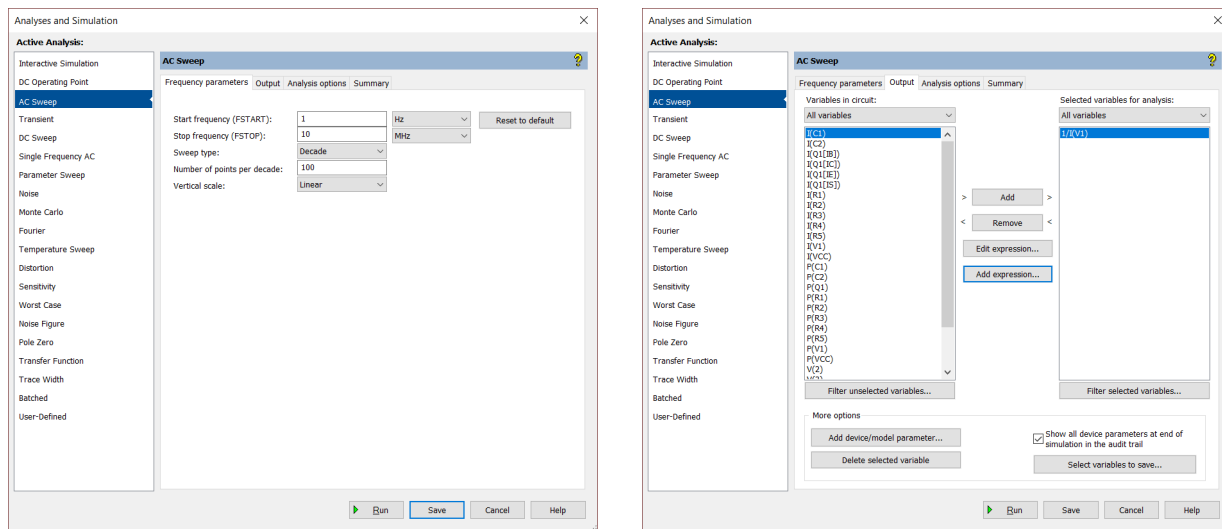

Figure 9: AC simulation setup for input resistance

- On the "Frequency Parameters" tab, select:
 - Start frequency (FSTART): **1 Hz**
 - Stop frequency (FSTOP): **10 MHz**
 - Sweep type: **Decade**
 - Number of points: **100**
 - Vertical scale: **Linear**
- On the "Output" tab, click on "Add expression...", type "1/I(V1)", then click on "OK" and "Save"
- Click on "Run" in Fig. 3
- Magnitude of 1/I(V1) is the input resistance R_i

1.10 Output Resistance (AC Simulation)

- Remove the input voltage source, insert an AC current source and connect it to the V_o node as in Fig. 10(a)
- Make sure that the "AC analysis magnitude" of the AC current source is set to 1 as in Fig. 10(b)

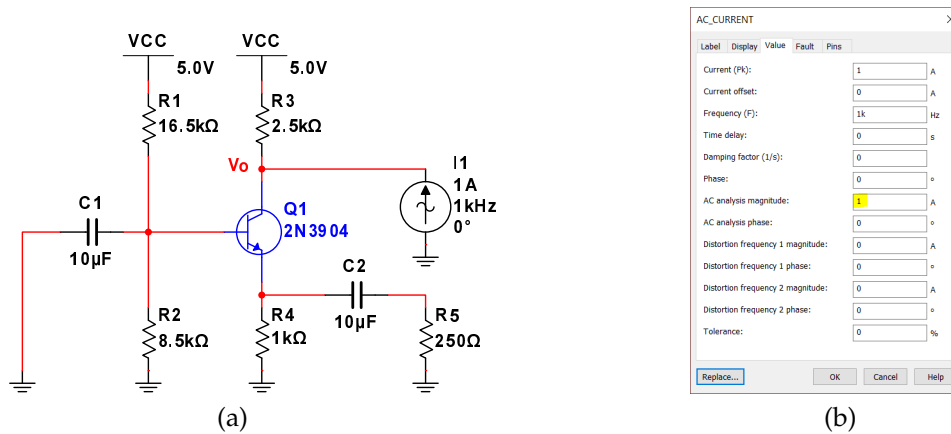

Figure 10: (a) Amplifier circuit for R_o simulation (b) AC current source properties

- Click on "Select Active Analysis" in Fig. 3, then click on "AC Sweep" (Fig. 11)

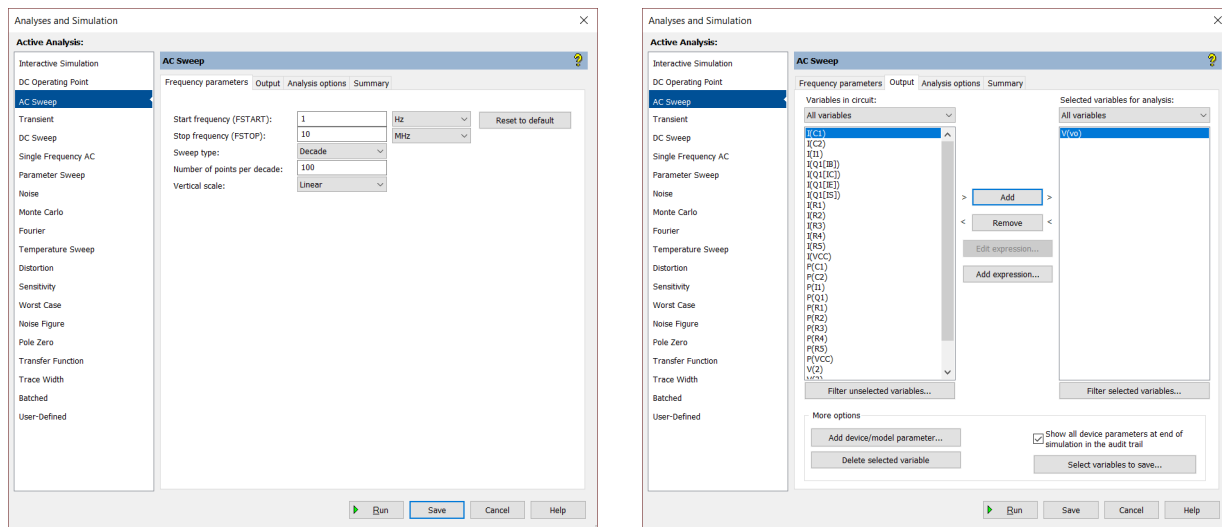



Figure 11: AC simulation setup for output resistance

- On the "Frequency Parameters" tab, select:
 - Start frequency (FSTART): **1 Hz**
 - Stop frequency (FSTOP): **10 MHz**
 - Sweep type: **Decade**
 - Number of points: **100**
 - Vertical scale: **Linear**
- On the "Output" tab, click on " $V(V_o)$ ", then "Add", then "Save"
- Click on "Run" in Fig. 3
- Magnitude of $V(V_o)$ is the output resistance R_o

1.11 Parameter Sweep

- From the Schematic Editor, click on "View" → "Circuit Parameters"
 - In the Circuit Parameters panel (bottom right corner), click on "Add parameter" button: 
 - Enter the name and value of the parameter
 - Use the parameter in the circuit for the variable to be swept
- Click on "Select Active Analysis" in Fig. 3, then click on "Parameter Sweep" (Fig. 12)

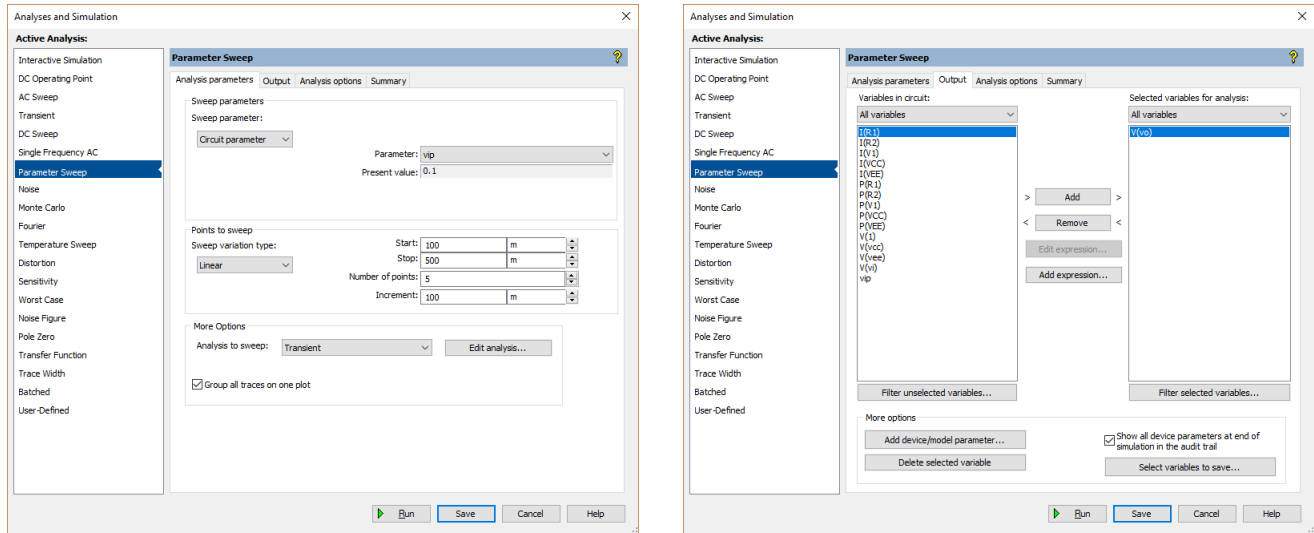

Figure 12: Parameter sweep setup

- On the "Analysis Parameters" tab, select:
 - Sweep Parameter: **Circuit parameter**
 - Parameter: **Choose from the list**
 - Enter the sweep type, start, stop and increment
 - Choose the "Analysis to Sweep"
 - Click on "Edit Analysis", and enter the analysis parameters
- On the "Output" tab, click on "V(Vo)", then "Add", then "Save"
- Click on "Run" in Fig. 3

1.12 Grapher View (Labeling Simulation Data at Specific Points)

- After running a simulation, grapher view window will show the plots. Fig. 13 shows the menu buttons.

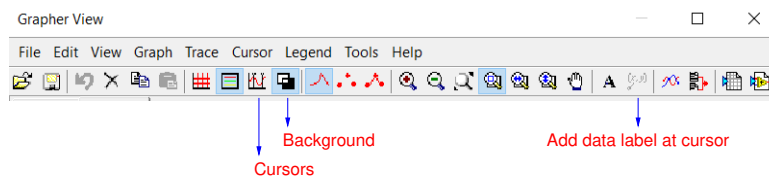

Figure 13: Grapher view menu buttons

- Use the "Background" button to toggle background (use white background for screenshots)
- Click on "Cursors" to measure simulated results, you can drag the cursors using the mouse
- Click on "Add data label at cursor" to label simulated values at specific points
- You can obtain the screenshot using "Snip & Sketch" in Windows

2 Analog Discovery 2

2.1 Power Supplies

- Connect Analog Discovery 2 to your computer and run Waveforms
- Connect **V+** to **Positive Supply**, **V-** to **Negative Supply**, **↓** to **ground**
- Click on "Supplies", set positive and negative supply voltages, then click on "Master Enable"

2.2 Bode Plots (Network)

- Connect Analog Discovery 2 to your computer and run Waveforms
- Connect **W1** and **1+** to **Vi (input)**, **2+** to **Vo (output)**, **1-, 2-, ↓** to **ground**
- Click on "Network", set "Start" to 100Hz and "Stop" to 1MHz
- Uncheck "Channel 1" (Yellow Box)
- Make sure the value of input amplitude does not saturate the output
- Click on "Single", magnitude and phase Bode plots will be drawn as shown in Fig. 14
- Click on View → Cursors
 - Click on "+Normal", then "+Delta", then "+Normal"
 - Move Cursor 1 to the flat part of the magnitude plot, then move Cursor 2 such that C2 ΔY is -3dB, so that the frequency of Cursor 2 corresponds to 3dB frequency
 - Move Cursor 3 to the specific input frequency (2kHz as an example) to measure the corresponding magnitude and the phase

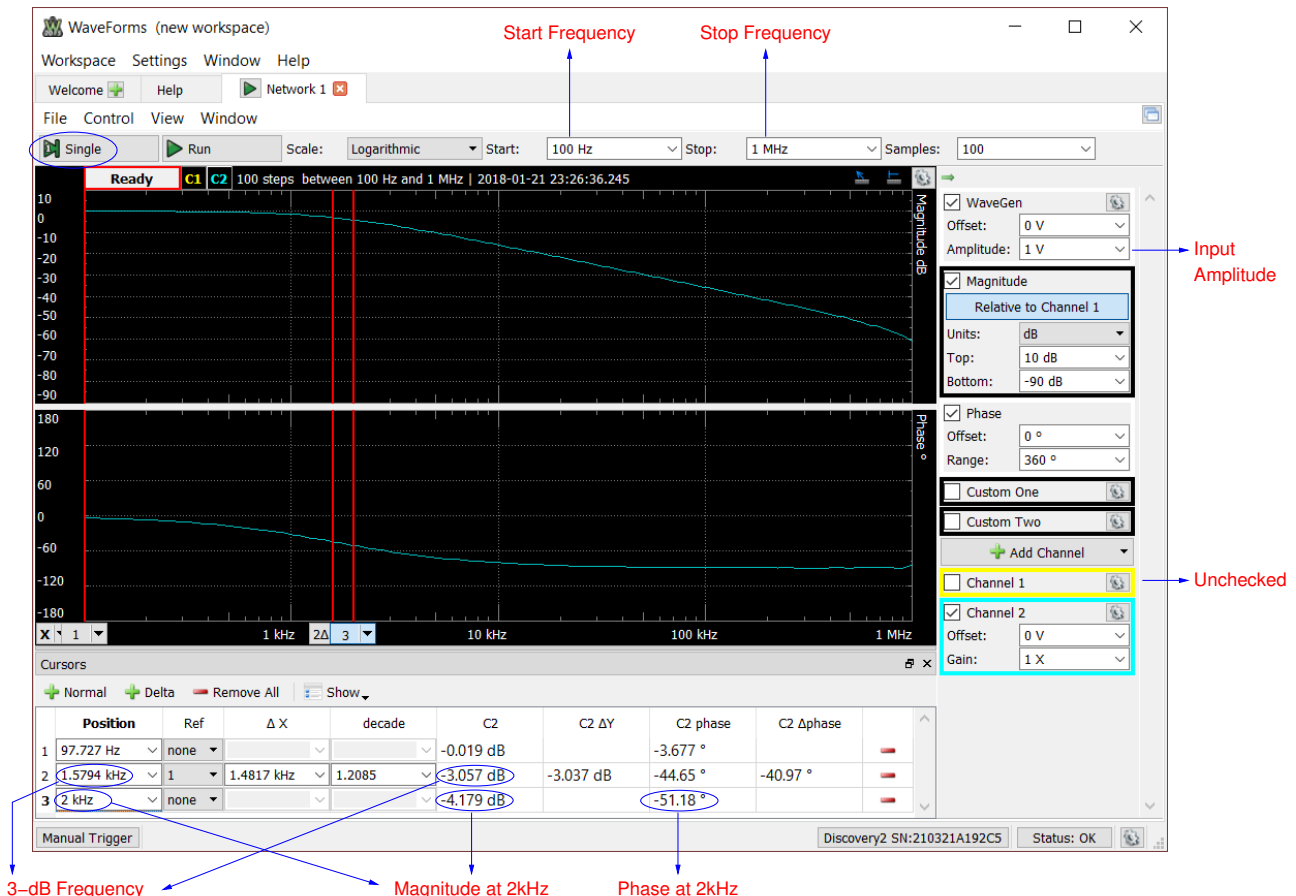

Figure 14: Network Analyzer Window

2.3 Time-Domain Waveforms (Scope)

- Connect Analog Discovery 2 to your computer and run Waveforms
- Connect **W1** and **1+** to **Vi (input)**, **2+** to **Vo (output)**, **1-, 2-, ↓** to **ground**
- Click on "Wavegen", enter the type, frequency and amplitude of the input waveform, and click on "Run"
- Click on "Welcome" tab, then on "Scope", then "Run"
- Time-domain waveforms should appear on the Scope window as shown in Fig. 15
- You can click on "Single" to hold the plot
- Click on View → Cursors
 - Click on "+Normal", then "+Delta", then "+Normal" and "+Normal"
 - Move Cursor 1 and 2 to zero-crossings of the input and the output, respectively, and calculate the phase difference from Δt
 - Move Cursors 3 and 4 to the maximum point of the input and the output, and calculate the magnitude of the transfer function

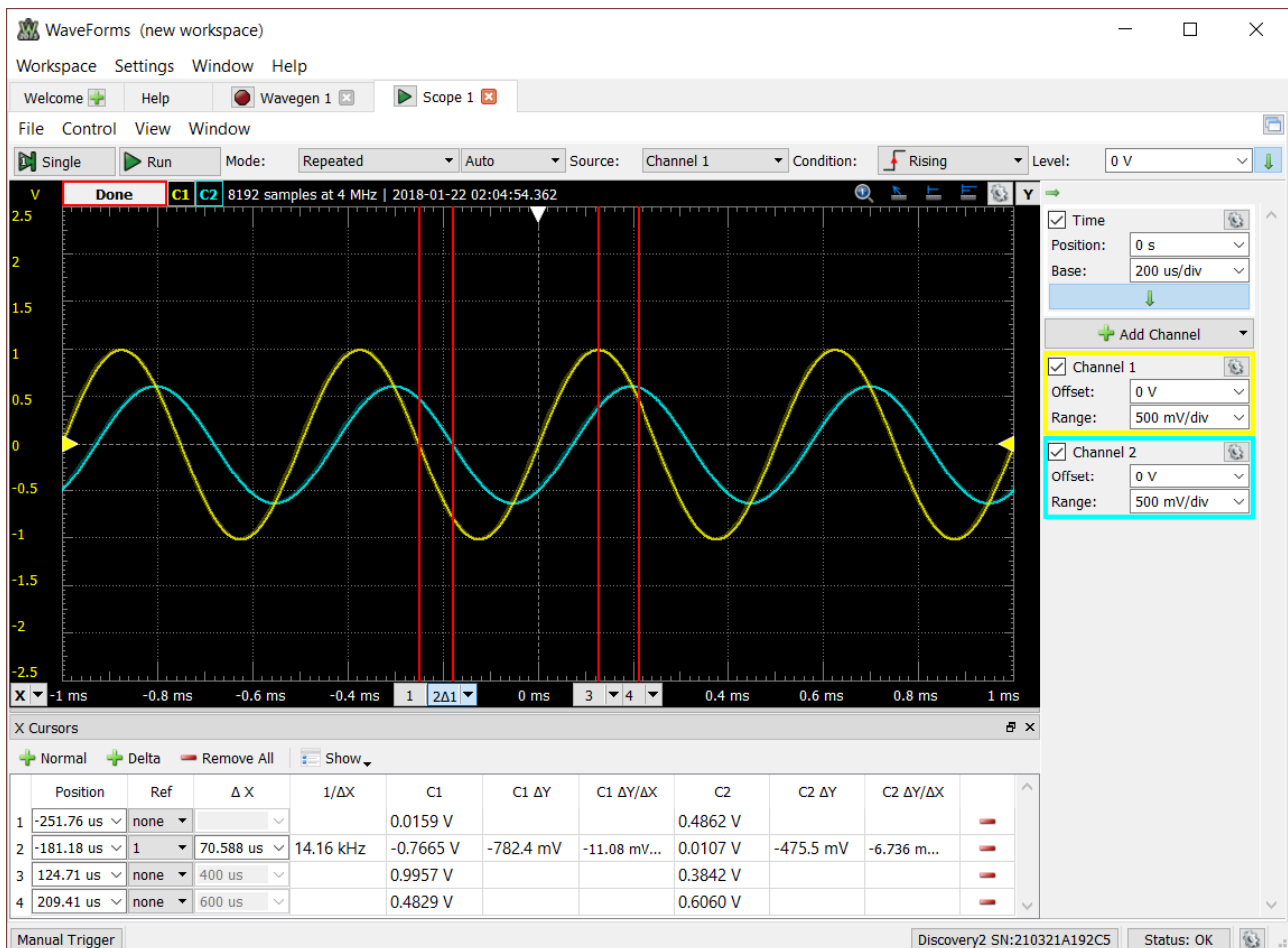

Figure 15: Scope Window

2.4 Total Harmonic Distortion (Spectrum)

- Connect Analog Discovery 2 to your computer and run Waveforms
- Connect **W1** and **1+** to **Vi (input)**, **2+** to **Vo (output)**, **1-, 2-, ↓** to **ground**
- Click on "Wavegen", enter the type, frequency and amplitude of the input waveform, and click on "Run"
- Click on "Welcome" tab, then on "Spectrum", then "Run"
- Output spectrum should appear on the Spectrum window as shown in Fig. 16
 - Uncheck "Trace 1" (Yellow Box)
 - Set "Stop" to $(N + 1)f_i$, where f_i is the input frequency and N is the number of harmonics
 - Set "Type" to "Linear dB Average"
 - Set "Count" to 10
- Click on "View" → "Measurements", on the Measurements Panel:
 - Click on "Add", then "Trace 2"
 - Expand the "Dynamic" menu (click on the arrow)
 - Click on "THD", then "Add", then "Close"
- Total Harmonic Distortion (THD) in % can be found using the following formula:

$$THD \text{ in } \% = 10^{(THD \text{ in dBc})/20} \times 100\%$$

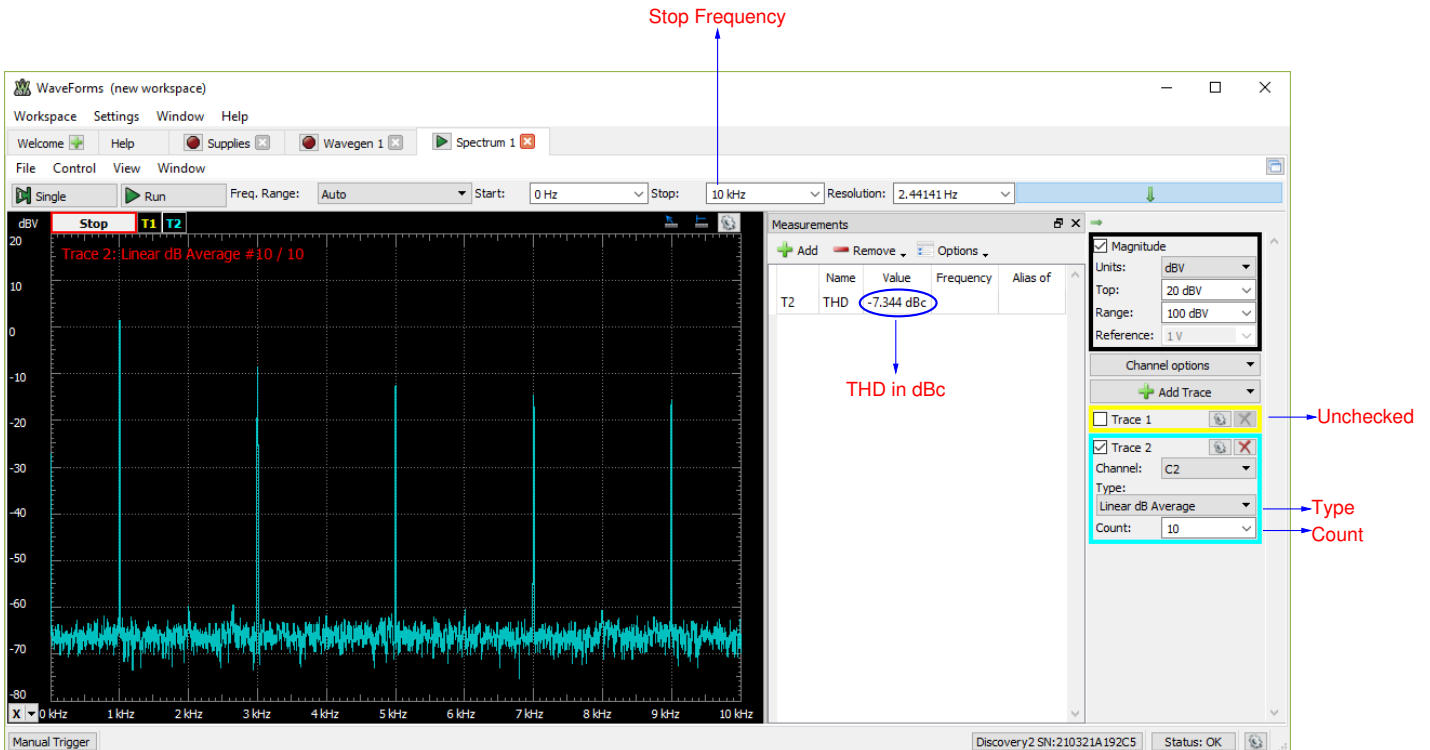

Figure 16: Spectrum Window

2.5 Input Resistance (Network)

- Connect Analog Discovery 2 to your computer and run Waveforms
- Insert a test resistor (R_{test}) that is close to the calculated value of the input resistance R_i as in Fig. 17

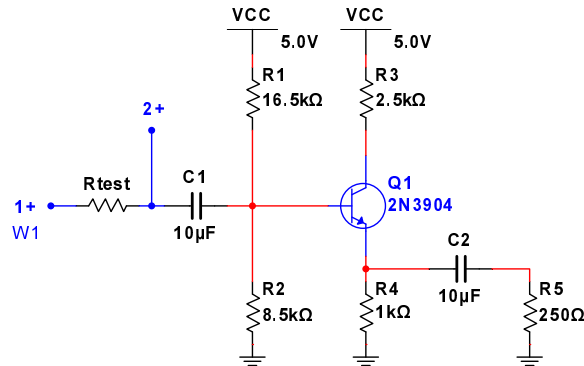

Figure 17: Amplifier setup for input resistance measurement

- Connect $W1$, 1+ and 2+ as shown in Fig. 17, 1-, 2-, ↓ to ground
- Click on "Network", set "Start" to 100Hz and "Stop" to 1MHz, uncheck "Channel 1"
- Make sure that the amplifier is not saturated
- Click on "Single", magnitude and phase Bode plots will be drawn
- Measure the magnitude within the flat portion, which is equal to $\frac{R_i}{R_{test} + R_i}$, then find R_i

2.6 Output Resistance (Network)

- Connect Analog Discovery 2 to your computer and run Waveforms
- Insert a test resistor (R_{test}) that is close to the calculated value of the output resistance R_o as in Fig. 18

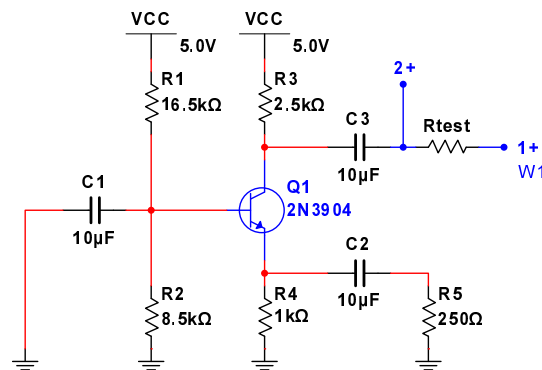

Figure 18: Amplifier setup for output resistance measurement

- Connect $W1$, 1+ and 2+ as shown in Fig. 18, 1-, 2-, ↓ to ground
- Click on "Network", set "Start" to 100Hz and "Stop" to 1MHz, uncheck "Channel 1"
- Make sure that the amplifier is not saturated
- Click on "Single", magnitude and phase Bode plots will be drawn
- Measure the magnitude within the flat portion, which is equal to $\frac{R_o}{R_{test} + R_o}$, then find R_o

3 Keysight MSO-X 3024T Oscilloscope

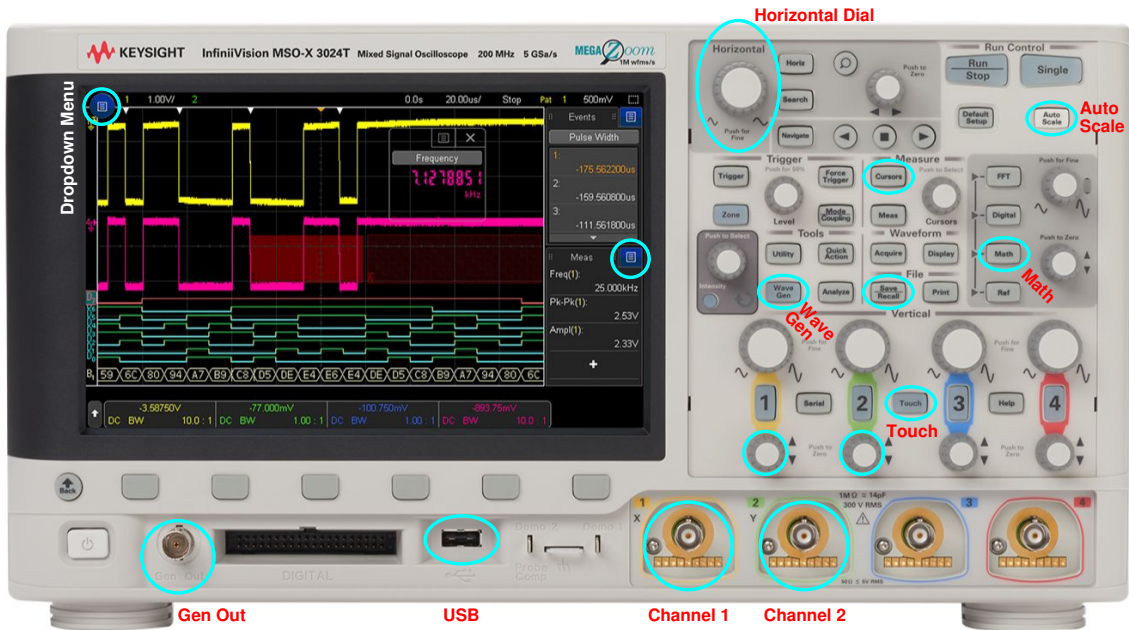

Figure 19: Keysight MSO-X 3024T oscilloscope front view

3.1 Bode Plots (Network)

- Connect **Gen Out** and **Channel 1** to **Vi (input)**, **Channel 2** to **Vo (output)**
- Make sure "Touch" is activated, then touch the dropdown menu  on the top left corner (see Fig. 19)
- Go to "Applications" and select "Frequency Response Analysis", then touch "Setup & Apply ..." (Fig. 20)
- Select your starting and stopping frequencies, points per decade, and input amplitude
- Make sure that the impedance is set to "High-Z", then touch "Run Analysis"



Figure 20: Frequency response setup window

- In the frequency response output window (Fig. 21), you can drag the triangles to use as cursors



Figure 21: Frequency response output window

3.2 Time-Domain Waveforms (Scope)

- Connect **Gen Out** and **Channel 1** to **Vi (input)**, **Channel 2** to **Vo (output)**
- Make sure "Touch" is activated, then push the "Wave Gen" button (see Fig. 19)
- Select your waveform, frequency, amplitude, and DC offset by touching the corresponding parameter (Fig. 22)

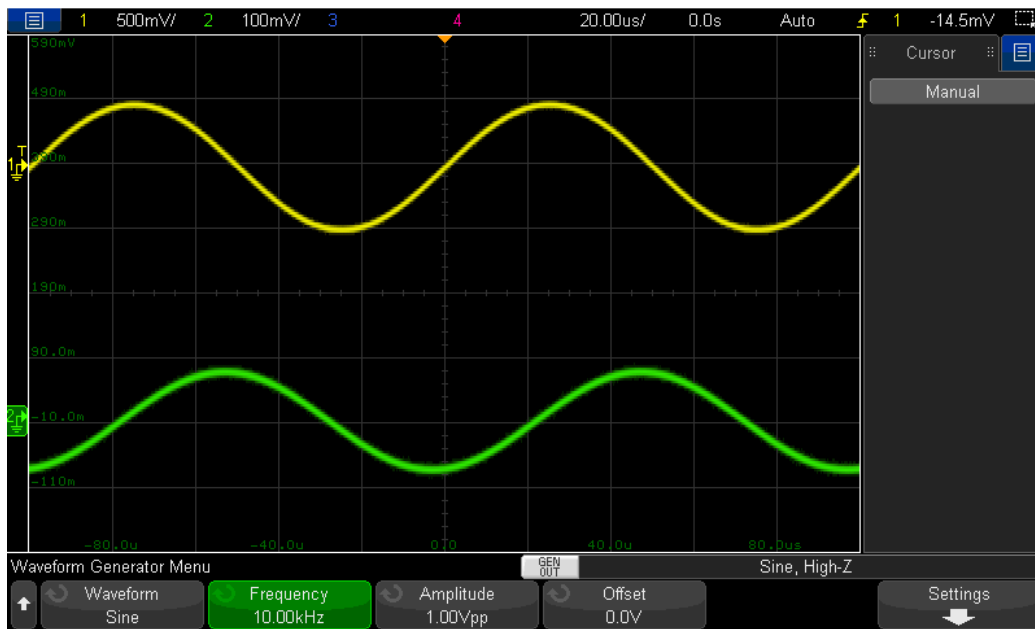

Figure 22: Scope window with waveform generator menu

- Push "Auto Scale"
- Push the dials under each channel button to zero the waveform offset

- Push "Cursors"
- Touch "Mode" and select "Manual"
- Touch and drag the cursors (see Fig. 23) to measure phase difference in seconds.

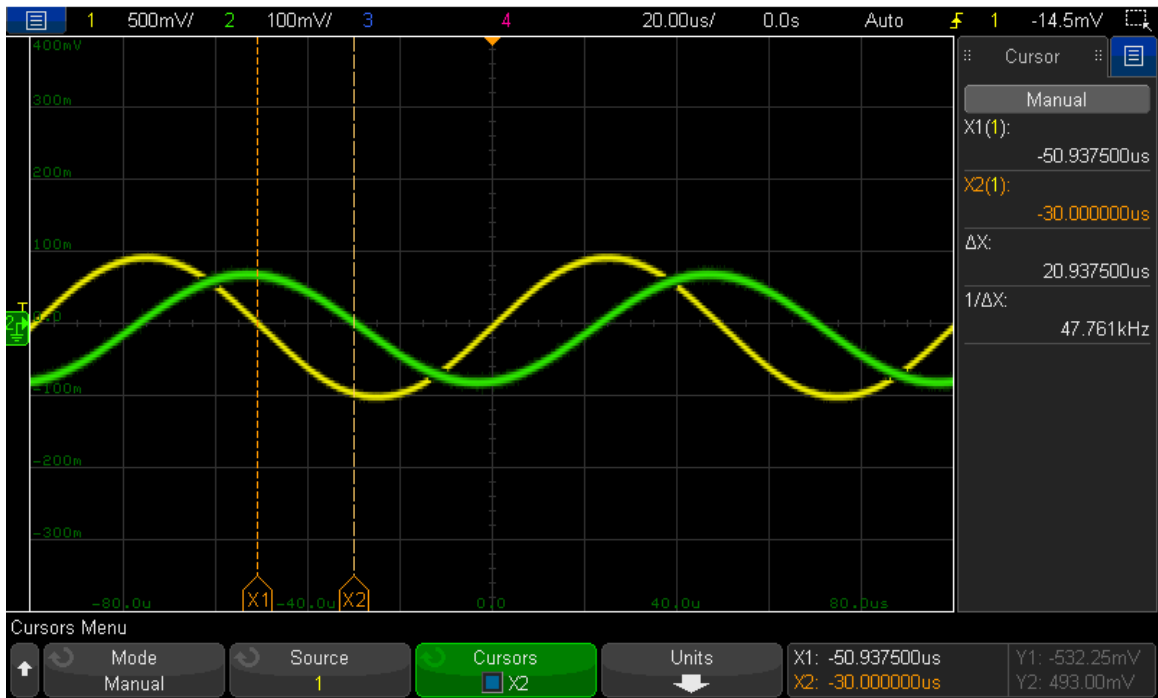

Figure 23: Using cursors to measure phase difference in seconds

- To measure phase difference in degrees, touch "Units", then "X Units Seconds", and then "Phase (°)" (see Fig. 24)

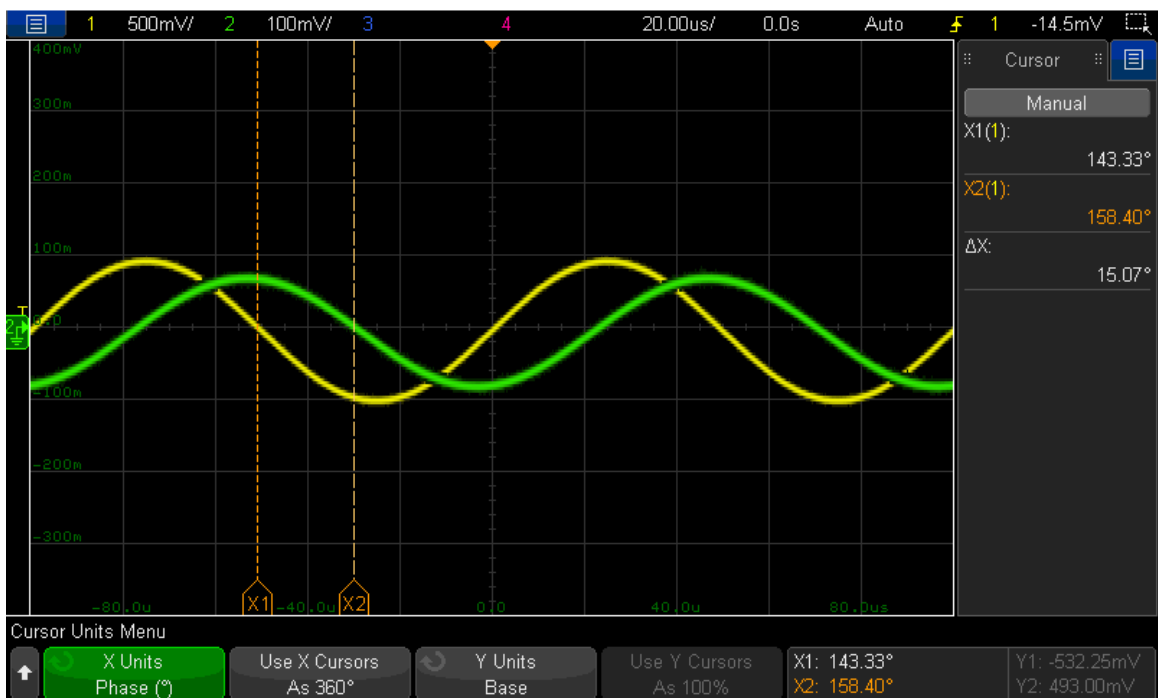

Figure 24: Using cursors to measure phase difference in degrees

3.3 Total Harmonic Distortion (Spectrum)

- Connect **Gen Out** and **Channel 1** to **Vi (input)**, **Channel 2** to **Vo (output)**
- Make sure "Touch" is activated, then push the "Math" button (see Fig. 19)
- Touch "Operator" and select "FFT (magnitude)"
- Make sure the source is selected as Channel 2
- If the touch options are "Center" and "Span", change them to "Start Freq" and "Stop Freq", and set their values
- Make sure you display sufficient number of periods for accurate computation; the number of periods can be adjusted by turning the "Horizontal Dial" in Fig. 19
- Touch "Display Math" and fill in the respective checkbox
- Touch the dropdown menu on the top right, next to "Meas"
- Touch "Measurements", then "Type", then "Total Harmonic Distortion", and then "Add Measurement"



Figure 25: Total harmonic distortion window

3.4 Input Resistance (Network)

- Insert a test resistor (R_{test}) that is close to the calculated value of the input resistance R_i as in Fig. 26

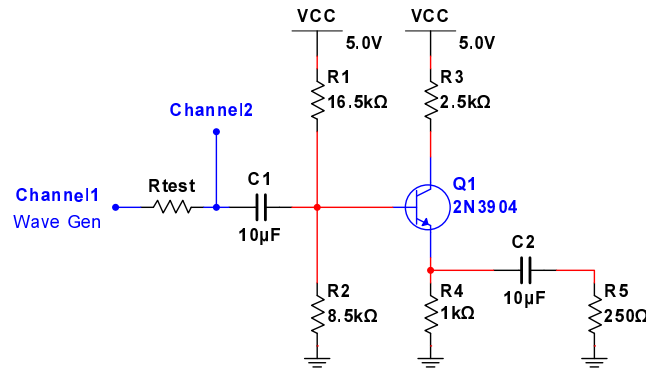



Figure 26: Amplifier setup for input resistance measurement

- Connect Channel 1, Channel 2 and Wave Gen as shown in Fig. 26
- Make sure "Touch" is activated, then touch the dropdown menu  on the top left corner (see Fig. 19)
- Go to "Applications" and select "Frequency Response Analysis", then touch "Setup & Apply ..." (Fig. 20)
- Select your starting and stopping frequencies, points per decade, and input amplitude
- Make sure that the impedance is set to "High-Z", then touch "Run Analysis"
- Measure the magnitude within the flat portion, which is equal to $\frac{R_i}{R_{test} + R_i}$, then find R_i

3.5 Output Resistance (Network)

- Insert a test resistor (R_{test}) that is close to the calculated value of the output resistance R_o as in Fig. 27

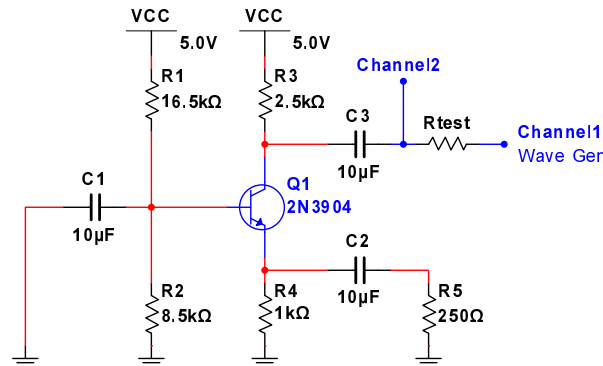



Figure 27: Amplifier setup for output resistance measurement

- Connect Channel 1, Channel 2 and Wave Gen as shown in Fig. 27
- Make sure "Touch" is activated, then touch the dropdown menu  on the top left corner (see Fig. 19)
- Go to "Applications" and select "Frequency Response Analysis", then touch "Setup & Apply ..." (Fig. 20)
- Select your starting and stopping frequencies, points per decade, and input amplitude
- Make sure that the impedance is set to "High-Z", then touch "Run Analysis"
- Measure the magnitude within the flat portion, which is equal to $\frac{R_o}{R_{test} + R_o}$, then find R_o

3.6 Exporting Data as an Excel (.csv) File

- Insert flash drive
- Push the "Save/Recall" button
- Touch "File Name" and enter the name
- Touch "Save"
- Touch "Format"
- Touch "CSV data (*.csv)"
- Touch "Press to go" and select the desired directory
- Touch "Press to Save"

3.7 Taking a Screenshot (.png)

- Insert flash drive
- Push the "Save/Recall" button
- Touch "File Name" and enter the name
- Touch "Save"
- Touch "Format"
- Touch "PNG 24-bit image (*.png)"
- Touch "Press to go" and select the desired directory
- Touch "Press to Save"