

ECEN721: Optical Interconnects Circuits and Systems Spring 2024

Lecture 3: Photodetectors



Sam Palermo
Analog & Mixed-Signal Center
Texas A&M University

Announcements

- Homework 2 is posted on website and due Feb 13
- Majority of material follows Sackinger Chapter 3

Optical Receiver Technology

- Photodetectors convert optical power into current
 - p-i-n photodiodes
 - Integrated metal-semiconductor-metal photodetector
- Electrical amplifiers then convert the photocurrent into a voltage signal
 - Transimpedance amplifiers
 - Limiting amplifiers
 - Integrating optical receiver

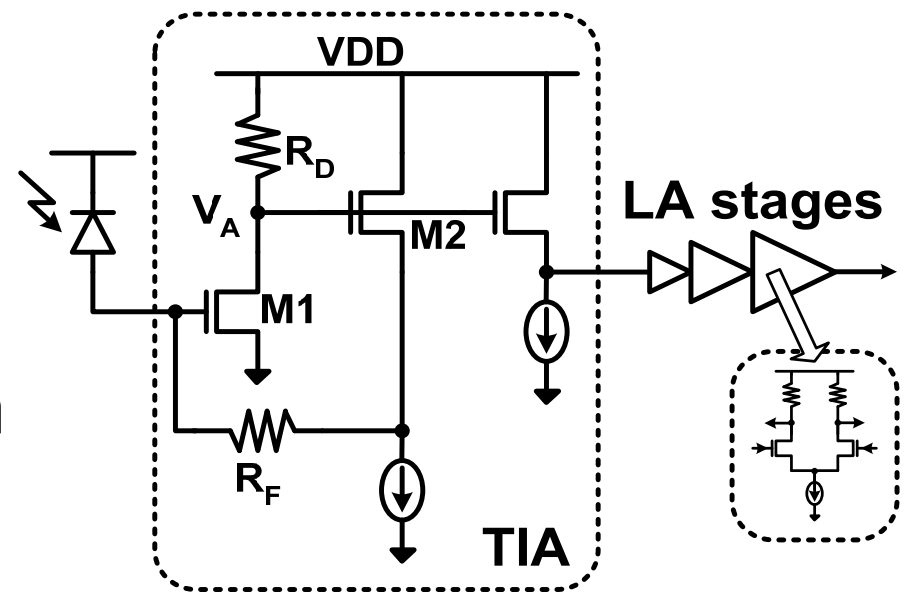

Photodetectors

- Photodetectors perform optical-to-electrical conversion and are the first elements in an optical receiver



[Albis]

- Their responsivity and noise performance significantly impact receiver performance
- Common photodetector types
 - p-i-n photodetector
 - Avalanche photodetector (APD)
 - Optically preamplified p-i-n detector

p-i-n Photodetector

- A p-i-n photodetector has an intrinsic layer (undoped or lightly doped) sandwiched between p- and n-doped material
- This p-n junction operates in reverse bias to create a strong electric field in the intrinsic region
- Normally incident photons create electron-hole pairs in the intrinsic region which are separated by the electric drift field, and photocurrent appears at the terminals

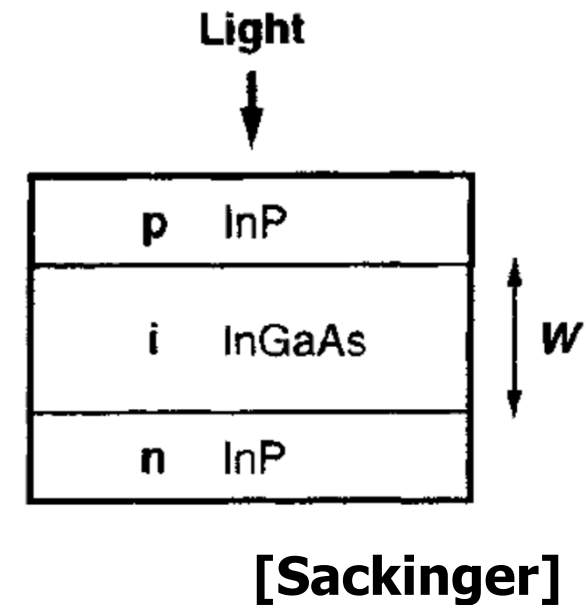

p-i-n Photodetector Tradeoffs

- There is a tradeoff between efficiency and speed set by the intrinsic layer width W
- The quantum efficiency η is the fraction of photons that create electron-hole pairs and is determined by W and detector's absorption coefficient α
- A wider W allows for higher η , but also results in longer carrier transit times which reduces the detector bandwidth

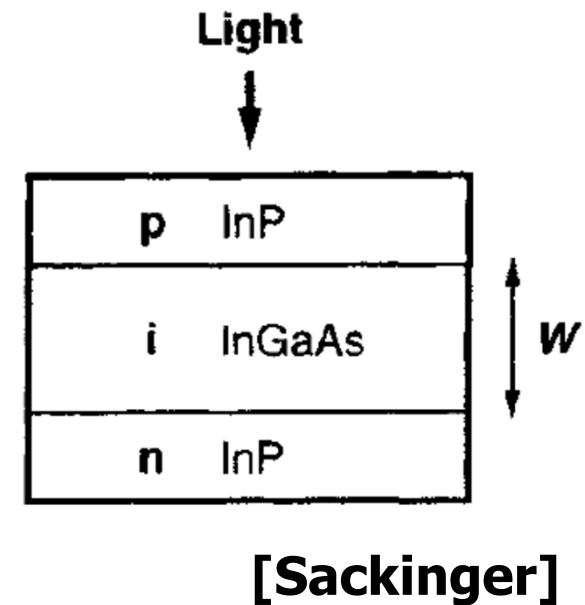

$$\eta \approx 1 - e^{-\alpha W}$$

Waveguide p-i-n Photodetector

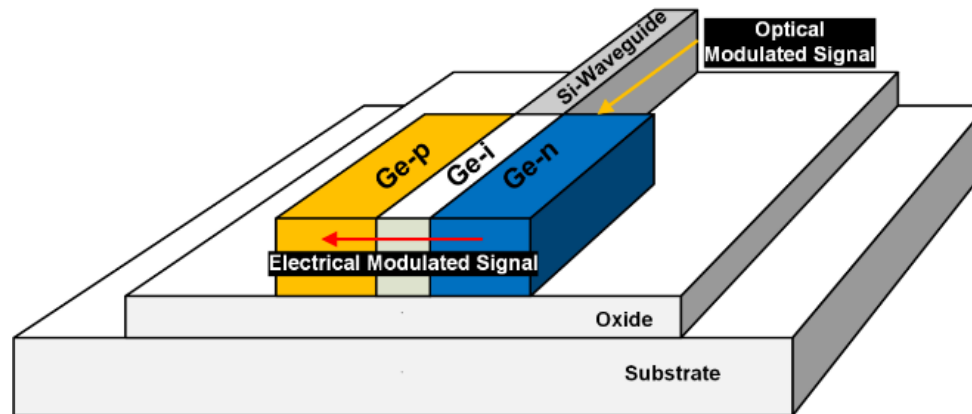

- A waveguide p-i-n photodetector structure allows this efficiency-speed trade-off to be broken
- The light travels horizontally down the intrinsic region and the electric field is formed orthogonal
- Allows for both a thin i-region for short transit times and a sufficiently long i-region for high quantum efficiency

Photodetector Materials

[National Instruments]

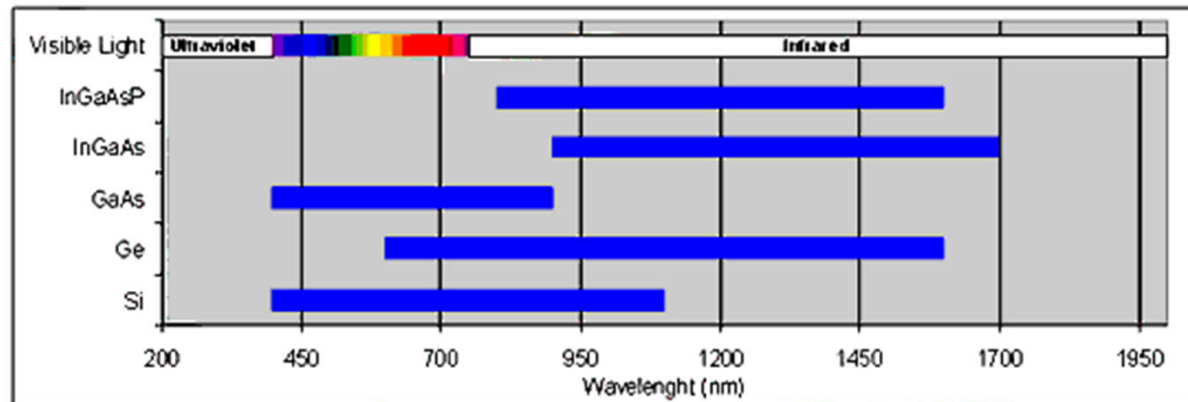

- Silicon detectors are useful for detecting visible light and the common 850nm region, but fail to absorb photons above 1060nm
- Common p-i-n detectors operating at 1310nm and 1550nm are made with InGaAs
- Silicon photonic waveguide photodetectors are often made with Ge

p-i-n Photodetector Responsivity

- The efficiency at which a photodetector converts optical power to electrical current is called **responsivity** R

- As each photon has energy of hc/λ ,

$$I_{PIN} = \eta \cdot \frac{\lambda q}{hc} \cdot P = R \cdot P$$

$$\text{where } R = \eta \cdot \frac{\lambda q}{hc} = (8 \times 10^5) \eta \lambda \text{ (A/W)}$$

- Example: A photodetector with $\eta=0.6$ operating at 1310nm has $R=0.63$ A/W
- There is the potential for $R>1$, with $\eta=1$ and 1550nm operation $\Rightarrow R=1.24$

Optical and Electrical Power

- As the optical power is linearly transformed into electrical current by the responsivity factor, the received electrical power increases with the **square** of the optical power
- We use the $10\log_{10}(P_{\text{opt}})$ to convert optical power to dB, or more commonly dBm
- Whereas we use $20\log_{10}(I_{\text{PIN}})$ to convert to current dBs
- A 3dB increase in optical power results in a 6dB increase in received electrical power! 😊
- Note that the current-to-optical power translation with a directly modulated laser is generally linear. So we have a square-root relationship at the transmitter side. ☹️

p-i-n Photodetector Equivalent AC Circuits

Bare Photodetector

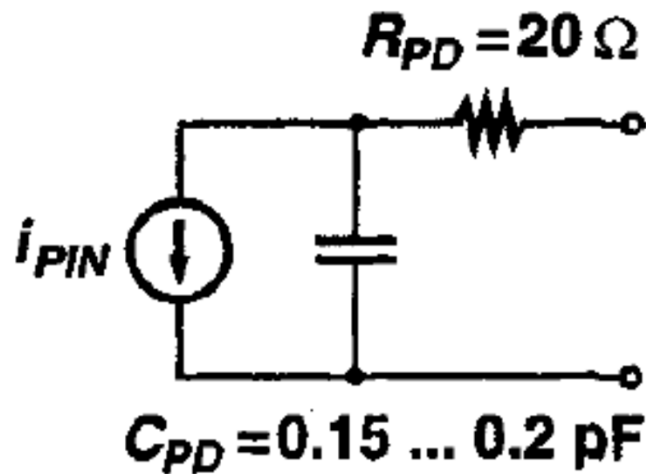

Photodetector + Packaging Parasitics

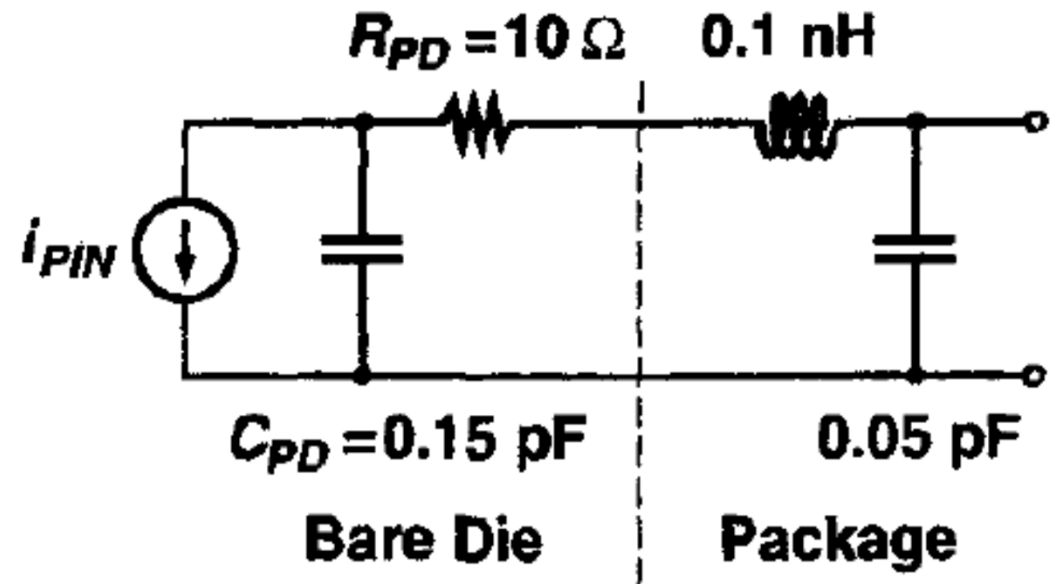

- The photodetectors main parasitics are the junction capacitance C_{PD} and contact/spreading resistance R_{PD}
- Additional LC parasitics are present in packaged devices due to wirebonds, etc...

p-i-n Photodetector Bandwidth

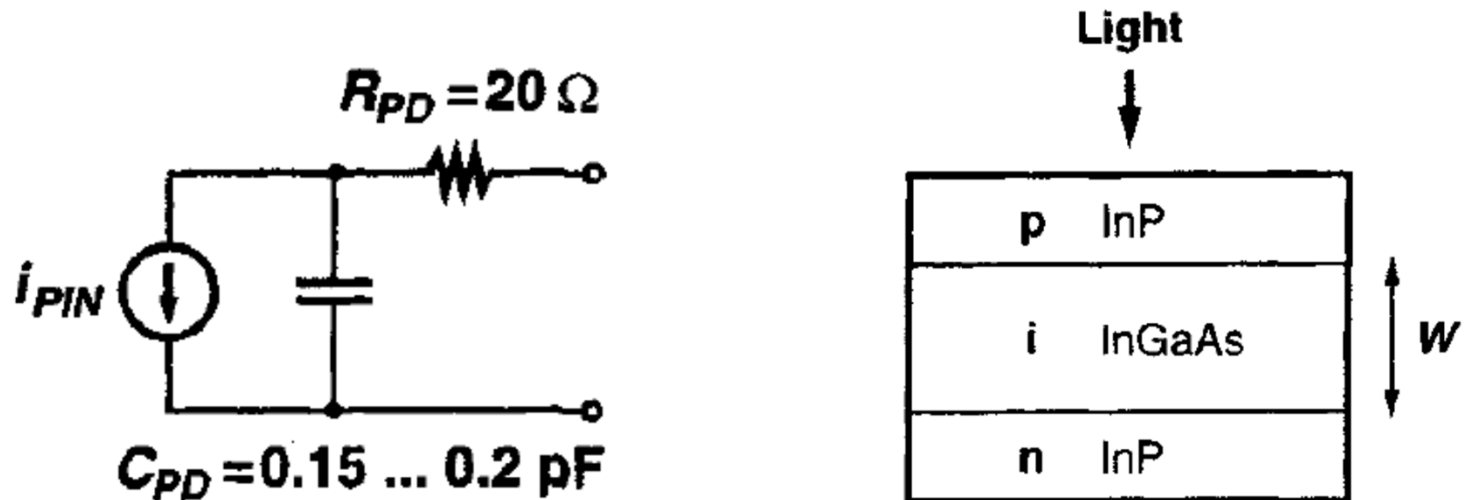

- Two time constants set the bare photodetector bandwidth

Transit Time: $\tau_{TR} = \frac{W}{v_n}$ where v_n is the carrier velocity

R - C Time Constant: $\tau_{RC} = R_{PD}C_{PD}$

The bandwidth in Hz can be approximated by

$$BW = \frac{1}{2\pi} \cdot \frac{1}{W/v_n + R_{PD}C_{PD}}$$

p-i-n Photodetector Shot Noise

- p-i-n photodetectors also produce a noise current, known as shot noise
- This noise is due to the photocurrent being comprised of a large number of short pulses distributed randomly in time
- It is modelled as having a white spectrum and a mean-square value of

$$\overline{i_{n,PIN}^2} = 2qI_{PIN} \cdot BW_n$$

where I_{PIN} is the signal current and BW_n is the bandwidth which we measure the noise current (receiver bandwidth)

Example: Average received optical power = 1mW, $R = 0.8A/W$, and a 10GHz receiver bandwidth

$$i_{n,PIN,rms} = 1.6\mu A_{rms}$$

$$SNR = 10\log_{10}(0.8mA/1.6\mu A)^2 = 54dB$$

Shot Noise Signal Dependency

- The shot noise is signal dependent, with the rms value growing with the square root of the optical power
- If we double the optical power, the SNR improves by 3dB
- The noise can vary on a per-bit basis
- Assuming a large extinction ratio (P_1/P_0)

$$\overline{i_{n,PIN,0}^2} \approx 0$$

$$i_{n,PIN,1}^2 = 2qR(2\bar{P})BW_n$$

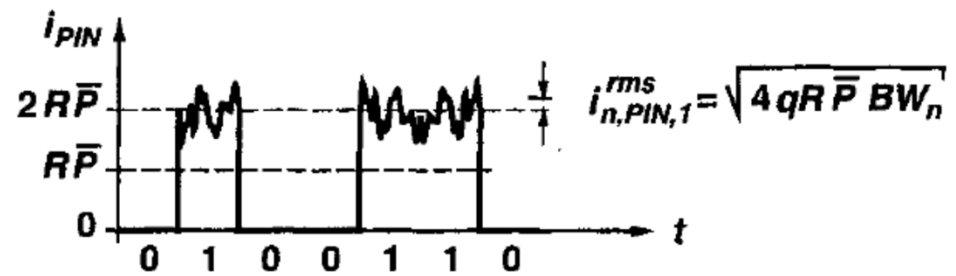

p-i-n Photodetector Dark Current

- The p-i-n photodetector produces current even when no light is present, called **dark current**
- Generally this dark current is only a few nA and not an issue, as long as it is less than 10% of the signal current

$$\bar{P} > 10 \cdot \frac{I_{DK}(\text{max})}{R}$$

p-i-n Photodetector Saturation Current

- The upper end of the p-i-n photodetector's dynamic range is defined by its **saturation current**
- The electron-hole pairs at very high optical power levels generate a space charge that counteracts the bias-induced drift field
- This results in decreased responsivity (gain compression) and reduced bandwidth
- Typical saturation currents are $>10\text{mA}$

Waveguide p-i-n Photodetector Example

42 GHz p.i.n Germanium photodetector integrated in a silicon-on-insulator waveguide

Laurent Vivien¹, Johann Osmond¹, Jean-Marc Fédéli², Delphine Marris-Morini¹, Paul Crozat¹, Jean-François Damlencourt², Eric Cassan¹, Y.Lecunff², Suzanne Laval¹

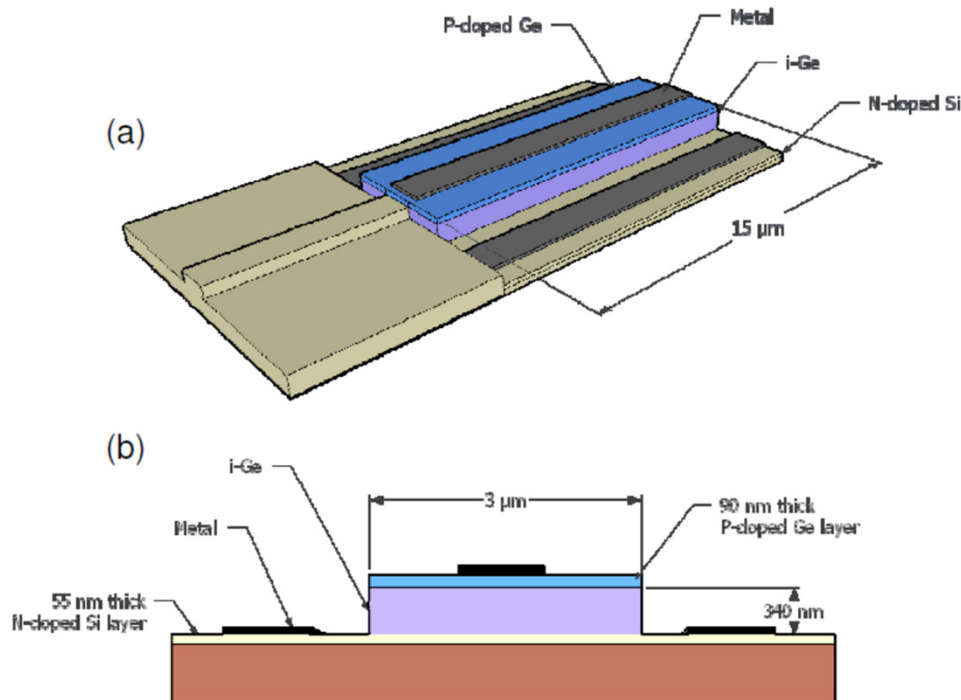

- Key performance metrics
 - 15 μm detector length
 - 42GHz bandwidth at 4V bias
 - 1A/W responsivity at 0.5V bias

Waveguide p-i-n Photodetector Example

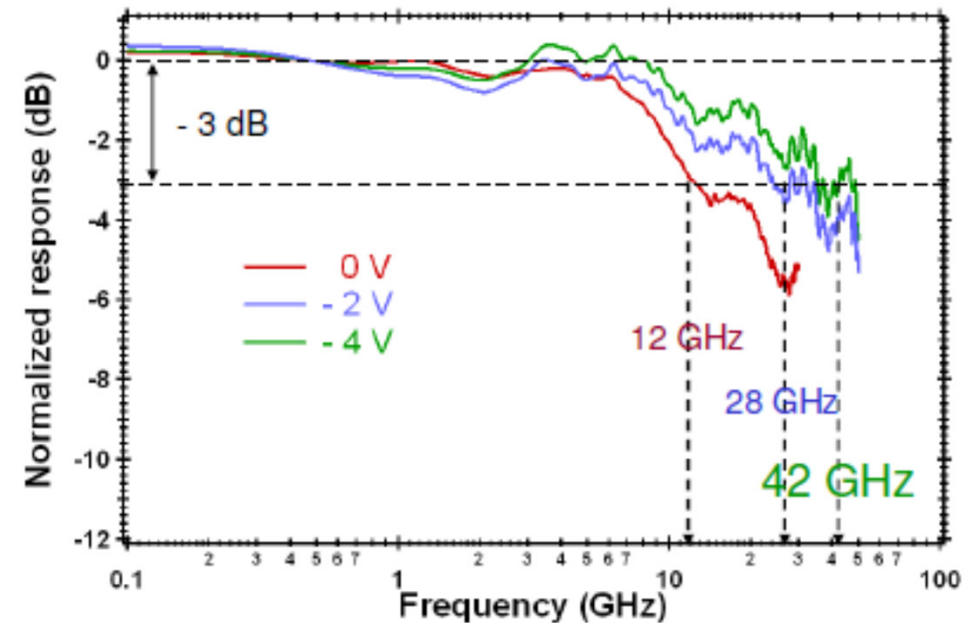
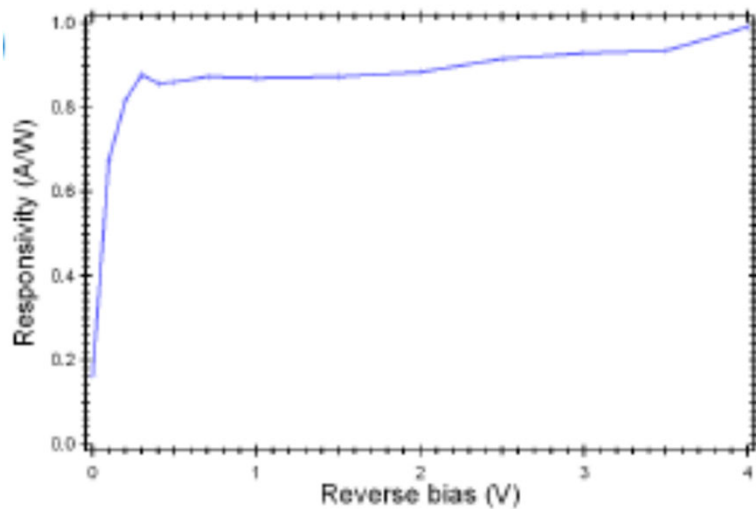
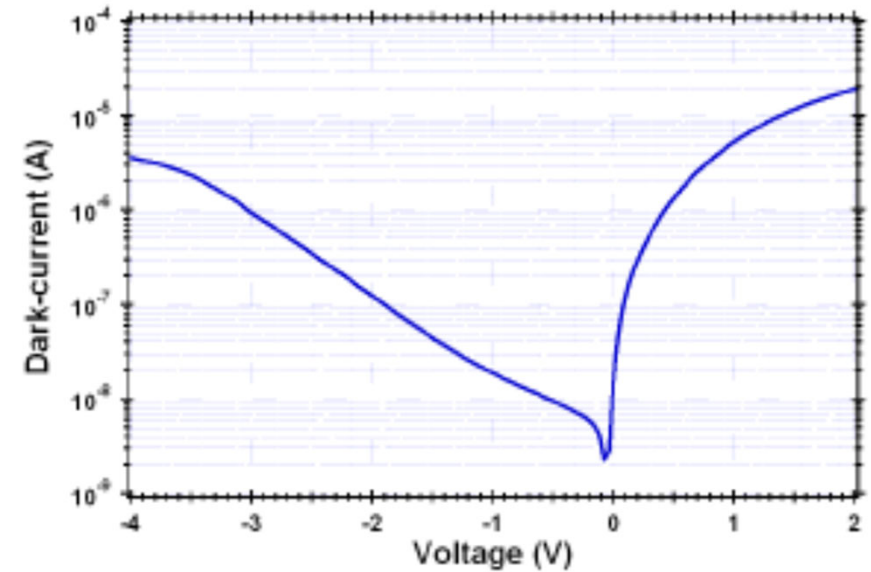
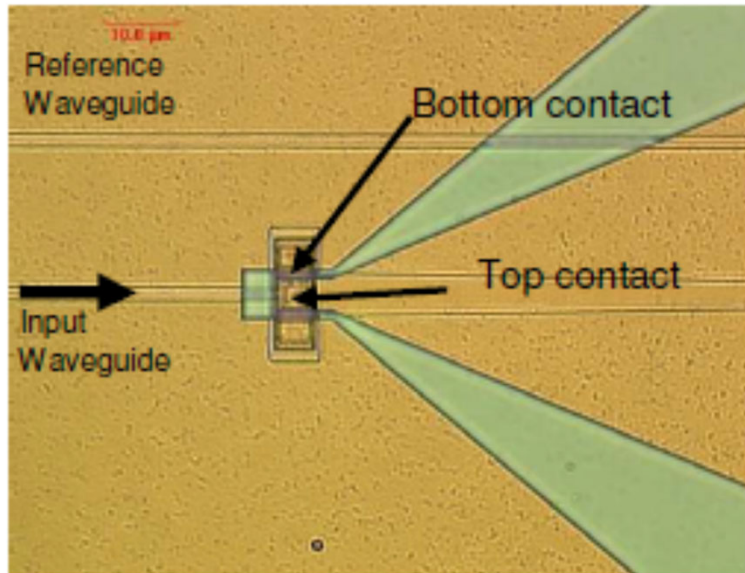

Avalanche Photodetector (APD)

- An avalanche photodetector adds a multiplication region to the p-i-n structure
- Electron-hole pairs generated in the intrinsic or absorption region experience avalanche multiplication
- A relatively high reverse bias ($>10\text{V}$) is necessary for the avalanche process to occur
- InP is often introduced to allow for higher electric fields

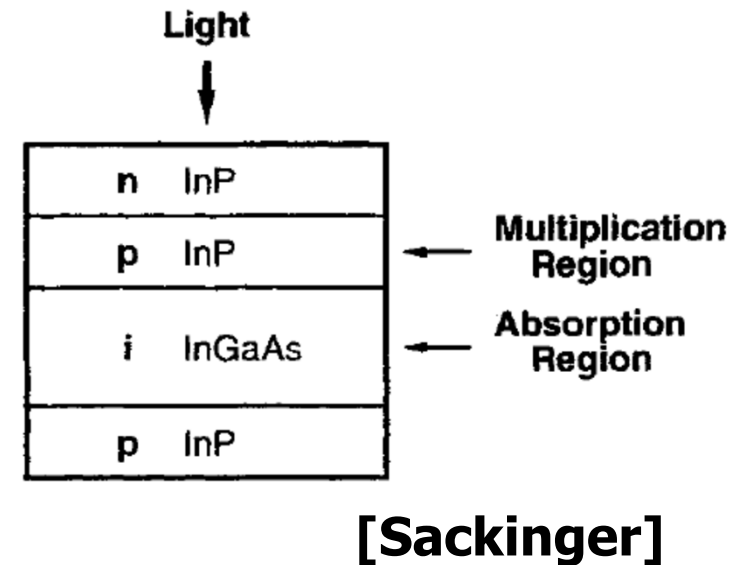

Avalanche Photodetector Responsivity

- APD gain is called avalanche gain or multiplication factor M

$$I_{APD} = M \cdot RP$$

where R is the responsivity without avalanche gain, which is similar to a p - i - n photodetector.

Example: with $R = 0.8A/W$ and $M = 10$, the APD generates $8A/W$

APD Gain Sensitivity

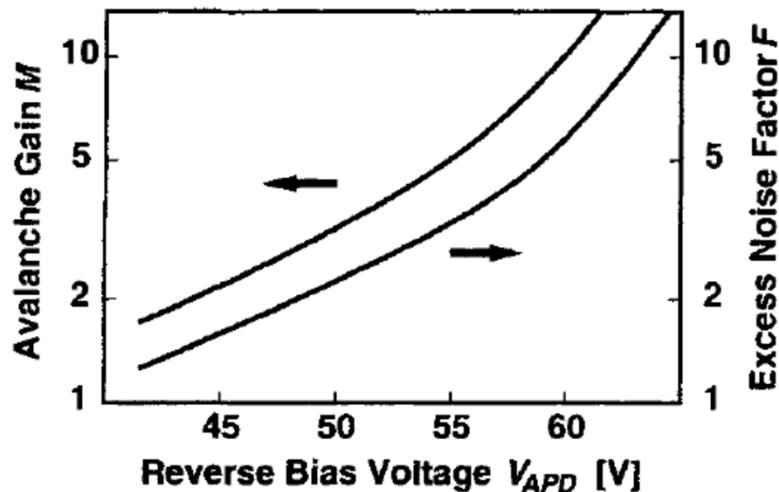

Temperature-Compensated APD

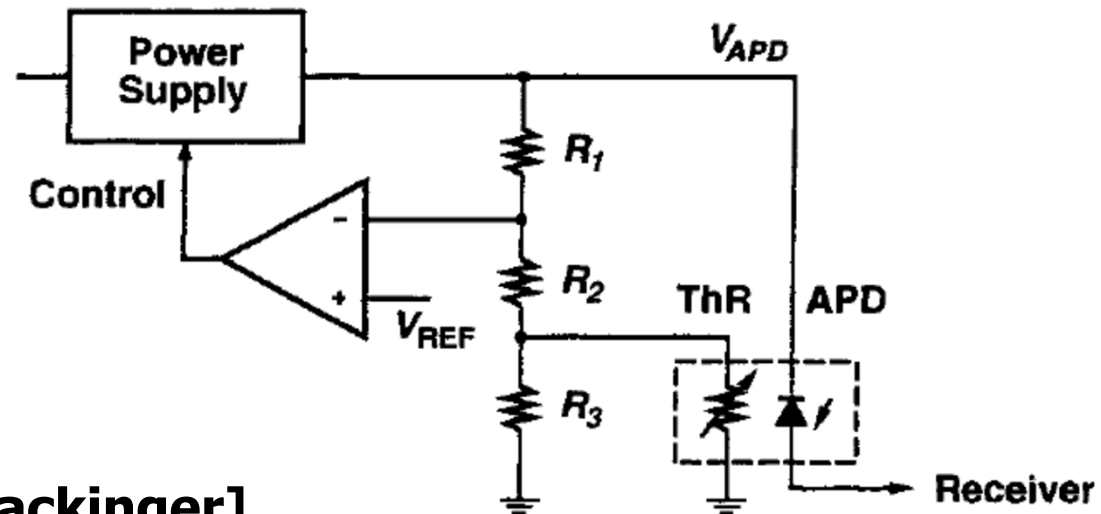

[Sackinger]

- APD gain is sensitive to both reverse bias and temperature
- Feedback control with temperature sensors can adjust the reverse bias to implement temperature compensate and/or automatic gain control

APD Avalanche Noise

- APDs also display additional noise, on top of scaled shot noise, as the multiplication is a random process, with M only representing the average current gain
- If the gain factor M was constant (it's not), then for every photogenerated electron M carriers would be produced and the shot noise would be

$$\overline{i_n^2}_{APD} = 2(Mq)(MI_{PIN})BW_n = M^2 2qI_{PIN}BW_n$$

$$\text{where } I_{PIN} = \frac{I_{APD}}{M}$$

- But, as M is a random process, an excess noise factor F is added to the APD noise

$$\overline{i_n^2}_{APD} = F \cdot M^2 2qI_{PIN}BW_n$$

APD Avalanche Noise

- The excess noise factor increases with reverse bias, roughly tracking the avalanche gain
- F and M are related, as a function of the ionization-coefficient ratio k_A

$$F = k_A M + (1 - k_A) \left(2 - \frac{1}{M} \right)$$

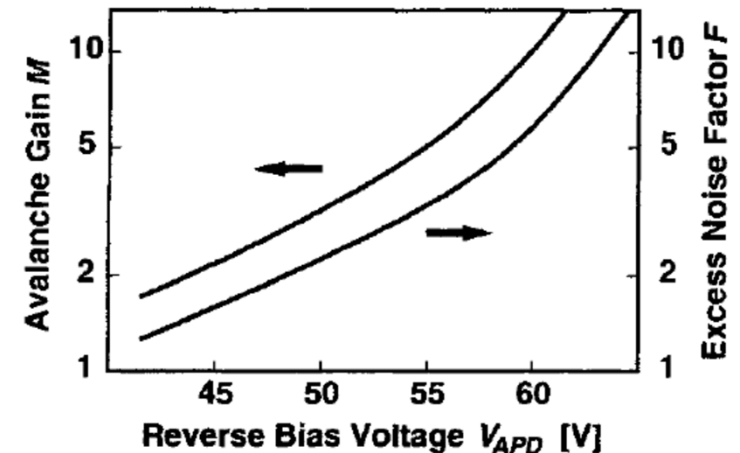

[Sackinger]

- Thus, there is an optimum M setting for receiver sensitivity
- As with the p-i-n photodetector, APD noise is also signal dependent

$$\overline{i_{n,APD,0}^2} \approx 0$$

$$\overline{i_{n,APD,1}^2} = F \cdot M^2 \cdot 2qR(2\overline{P})BW_n$$

APD Dark Current

- APDs also display dark current, quantified as a primary dark current I_{DK} which is amplified to MI_{DK}
- This produces additional shot noise

$$\overline{i_n^2}_{APD,DK} = F \cdot M^2 \cdot 2qI_{DK}BW_n$$

- For well designed APDs, the primary dark current is on the order of a few nA and doesn't have a major impact on receiver sensitivity
- But if M is high, the receiver should be designed to tolerate this additional current

APD Bandwidth

- If we increase the reverse bias the APD gain (and excess noise) will increase, but the bandwidth will unfortunately reduce
- APD gain-bandwidth product remains approximately constant with different bias levels, and can be used to quantify the device's speed
- High-performance APDs have GBWs of 100-150GHz
- We can model the APD with a similar RC circuit

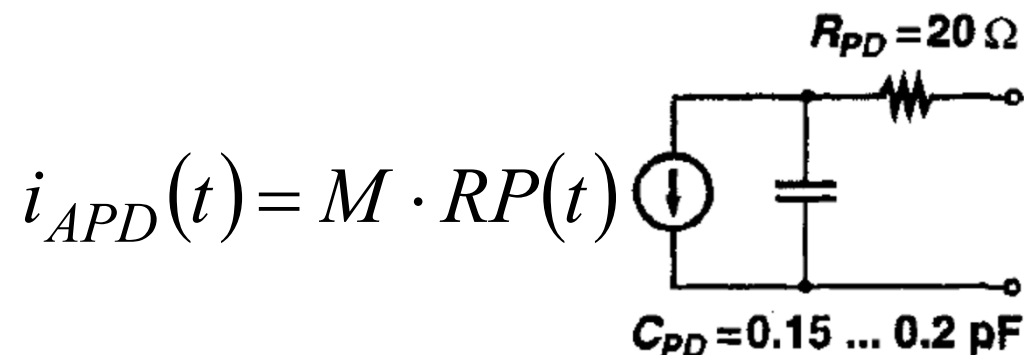

p-i-n Detector w/ Optical Preamplifier

- Fabricating APDs with high GBW can be difficult
- Utilizing an optical amplifier before a p-i-n detector can support higher data rates
- These optical amplifiers can provide gain over a wide optical bandwidth, such as 10nm or $\sim 1.25\text{THz}$
- Generally, utilizing an optical preamp and p-i-n detector will yield better noise performance relative to an APD
- Major trade-off is the cost of the optical amplifier

Optical Amplifiers

- Semiconductor optical amplifier (SOA)

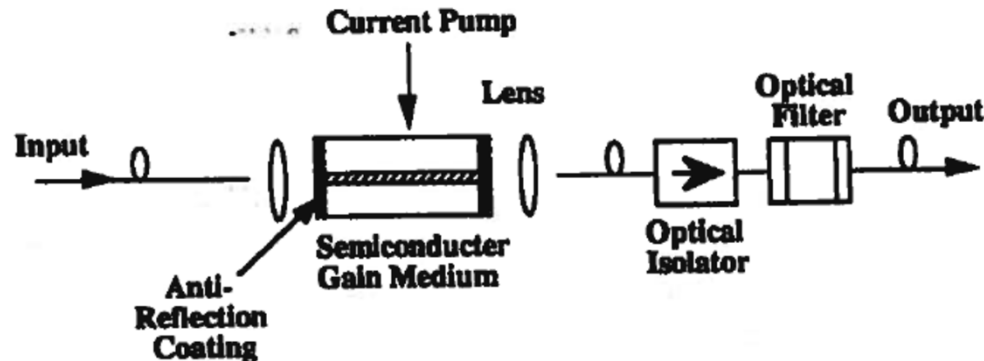

[Kazovsky]

- Erbium-doped fiber amplifier (EDFA)

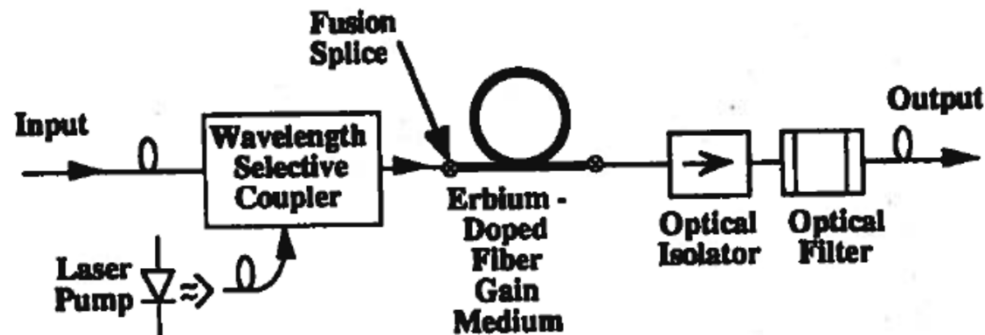

- SOAs can be small and perhaps integrated on the same PIC as the p-i-n detector (not SiP)
- EDFAs generally offer better performance and are more popular, despite their size overhead

Erbium-Doped Fiber Amplifier (EDFA)

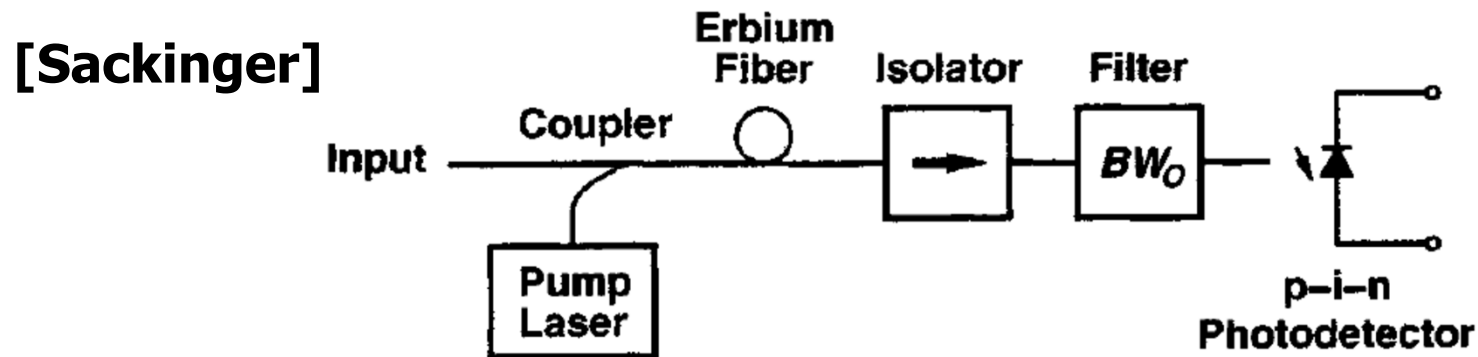

- An optical coupler combines the received optical input signal with light from a continuous-wave (CW) pump laser source
 - These two light sources are sent through an erbium-doped fiber, typically $\sim 10\text{m}$, where amplification occurs via stimulated emission
 - An isolator follows to prevent feedback and instability
 - A filter is also used to suppress amplified spontaneous emission (ASE) noise, which has a white spectrum with a PSD of S_{ASE}
- $$P_{ASE} = S_{ASE} \cdot BW_O$$

EDFA Gain

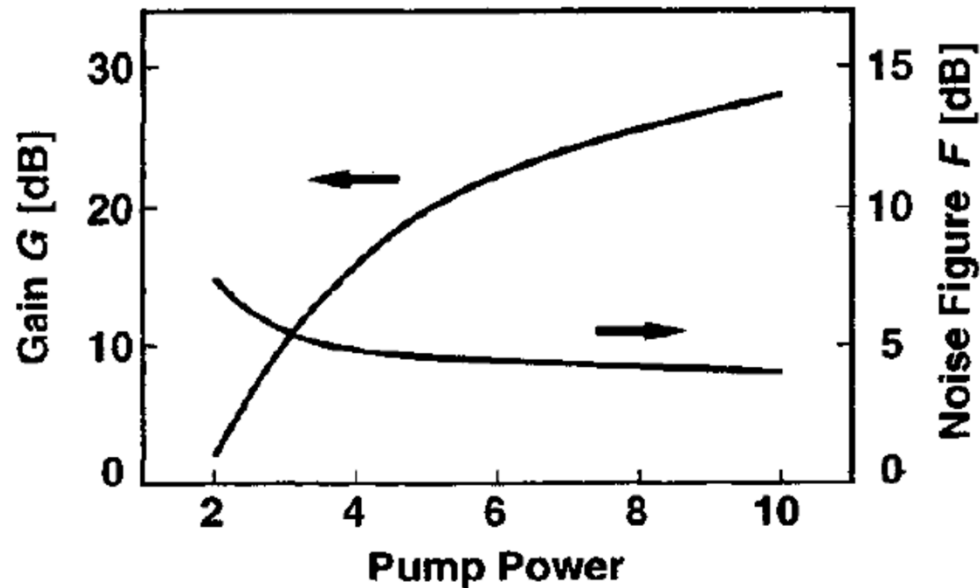

[Sackinger]

- The EDFA introduces a power gain G which is a function of the erbium-doped fiber length and the pump power
 - Typical value is 10 or 20dB
 - This is 10X a typical APD M factor
- An input power P into the EDFA results in the following p-i-n detector current

$$I_{OA} = G \cdot RP$$

Amplified Spontaneous Emission (ASE) Noise

- As the photodetector responds to the incoming light intensity and performs a squaring operation, a signal-dependent ASE term results

$$(signal + noise)^2 = (signal)^2 + 2(signal \cdot noise) + (noise)^2$$

The ASE noise terms are

$$\overline{i_{n,ASE}^2} = R^2 \left(\underline{2P_S S_{ASE}} + S_{ASE}^2 BW_O \right) BW_n$$

where P_S is the signal power at the output of the EDFA, $P_S = GP_{in}$

- The **signal-spontaneous beat noise** is generally the dominant term and is not affected by the optical filter bandwidth, but the electrical receiver bandwidth
- The spontaneous-spontaneous beat noise can be reduced with the optical filter

SNR w/ an EDFA RX

The received signal current average power in the electrical domain is

$$\overline{i_S^2} = R^2 P_S^2$$

and the ASE noise power is

$$\overline{i_{n,ASE}^2} = R^2 \left(2P_S S_{ASE} + S_{ASE}^2 BW_O \right) BW_n$$

Using $P_{ASE} = S_{ASE} BW_O$, the SNR is

$$SNR = \frac{\overline{i_S^2}}{\overline{i_{n,ASE}^2}} = \frac{R^2 P_S^2}{R^2 \left(2P_S S_{ASE} + S_{ASE}^2 BW_O \right) BW_n} = \frac{(P_S / P_{ASE})^2}{P_S / P_{ASE} + 1/2} \cdot \frac{BW_O}{2BW_n}$$

The ratio P_S / P_{ASE} is known as the optical SNR (OSNR)

$$SNR = \frac{OSNR^2}{OSNR + 1/2} \cdot \frac{BW_O}{2BW_n} \approx OSNR \cdot \frac{BW_O}{2BW_n}$$

- The electrical SNR is well approximated by scaling the OSNR by the ratio of the optical filter bandwidth over twice the electrical receiver bandwidth

EDFA Noise Figure

- Optical amplifier noise figure is defined as the ratio of the total output noise power to the fraction of the noise power due to the shot noise of the optical source

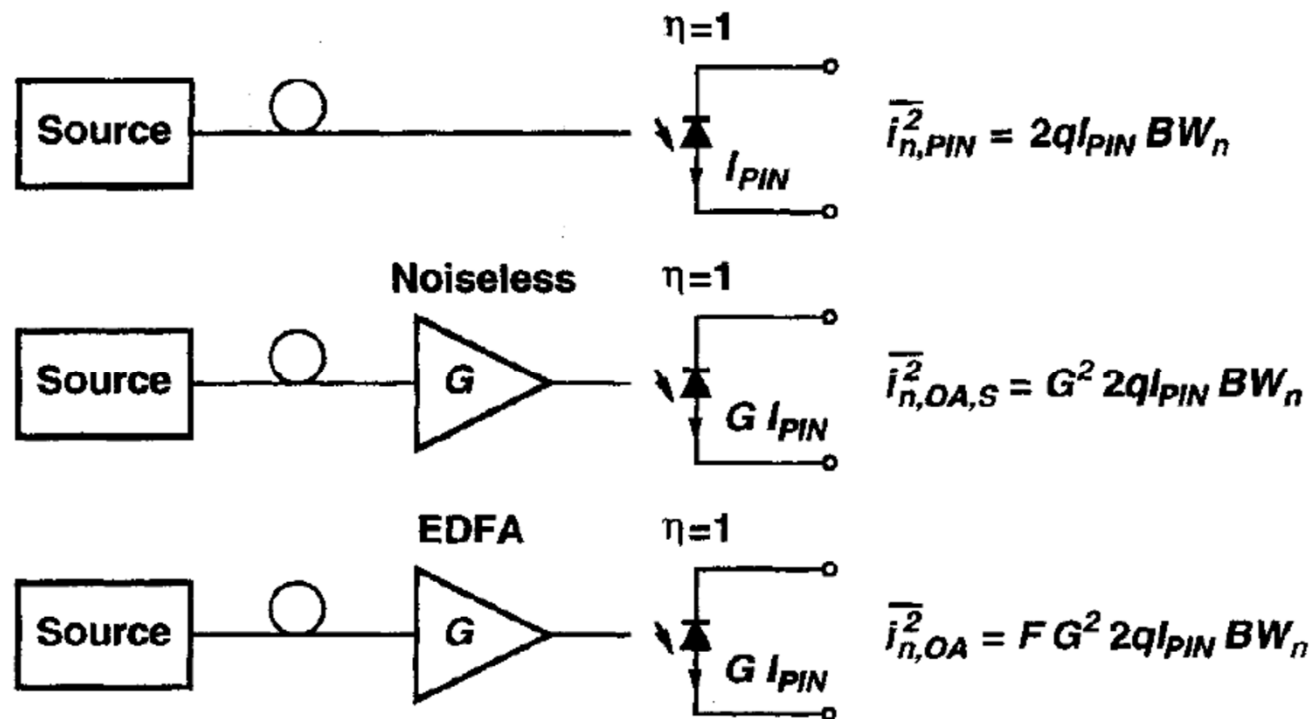

EDFA Noise Figure

- If we assume that the EDFA ASE noise dominates, i.e. neglect the shot noise to calculate F

$$\overline{i_{n,OA}^2} = \overline{i_{n,ASE}^2}$$

$$FG^2 2qI_{PIN} BW_n = R^2 \left(2P_S S_{ASE} + S_{ASE}^2 BW_O \right) BW_n$$

$$F = \frac{\lambda}{hc} \left(\frac{S_{ASE}}{G} + \frac{S_{ASE}^2}{2G^2 P} BW_O \right)$$

Signal-Spontaneous Beat Noise

Spontaneous-Spontaneous Beat Noise

- Note that the noise figure depends on the input power P
- However, for reasonable input power levels and/or small optical bandwidths the first term typically dominates and we can define a signal-spontaneous beat noise limited noise figure

$$\tilde{F} = \frac{\lambda}{hc} \cdot \frac{S_{ASE}}{G}$$

Summary

- p-i-n detectors have typical responsivities between 0.6-0.9A/W and are mostly used in short-haul applications
- APDs have typical effective responsivities between 5-20A/W and are used in long-haul applications, but their GBW can limit operation above 10Gb/s
- Using an optical amplifier – p-i-n detector combination allows for typical effective responsivities between 6-900A/W and can achieve higher data rates for long-haul applications
- All of these detectors generate current \propto to optical power
- All also have signal-dependent noise currents
 - p-i-n have shot noise
 - APDs have avalanche noise quantified by the excess noise factor F
 - Optical pre-amplifier systems are often dominated by ASE noise, which determines their noise figure F

Next Time

- Receiver Analysis
 - Sackinger Chapter 4